

novelties

nowa szkoła

2022

international





For over 30 years, Nowa Szkoła has been creating and promoting a new look in the children's world of education. With each year we gain experience and knowledge, which we translate into higher-quality services focused towards developing the educational space.

We know very well the needs of children and teachers. Yet, in order to be absolutely sure that our offers will fully meet their expectations we consult qualified educators about each new product idea. And for the testing phase we invite children – the best experts on quality and safety.

To be competitive we have always observed certain principles. Thanks to our good planning and implementation, choice of top-quality materials and professional workmanship our products are safe for children and user-friendly for teachers.

Our priorities are always our customers' needs and transparency of business practices. By adhering to these fundamentals, we wish to strengthen our good relations with clients.







- Surface 420 m².
- Well-equipped machine park i.a. rotating blades, lockstitch machines, overlock machines, foam cutting plotters.



SEWING WORKROOM AND PACKING

From the very beginning of our company's existence, we have been investing in professional production solutions. With the everchanging needs of the customers in mind, we constantly expand our machine park by purchasing new machines.



CARPENTRY WORKSHOP

- Surface 1750 m²
- Well-equipped machine park i.a. panel saw, sliding table saw, curve and straight-line edge bander, CNC drilling machine, multi-spindle drilling machine, nesting machining centre.



- A modern high bay warehouse. Its design meets the contemporary standards of sustainable development.
- Surface 9 656 m².
- The height of the warehouse: 10 m. – certified with the ISO 9001:2015 Quality Management System.
- The number of pallet spaces: 16 292.
- Parcel sorting line for courier services.
- Modern WMS which controls the flow of goods.
- The Data Matrix system enabling code verification.
- The automated palletising system.
- A convenient location with well-developed road infrastructure.

WAREHOUSE

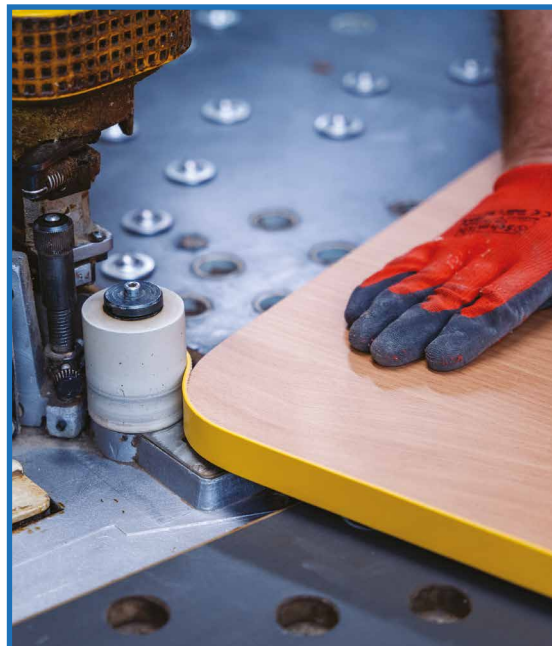
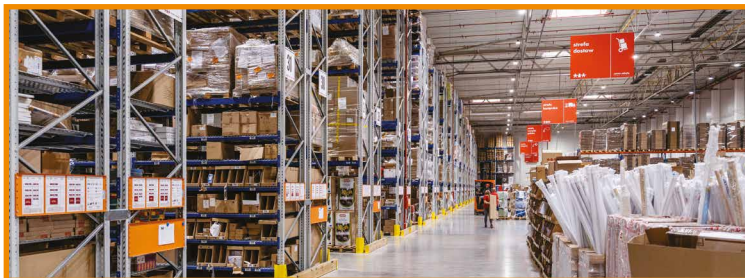

BIRCH



Cubo, Fresh, Prima, Modern, Pastel, Rainbow, Fantasy, Minty, Modul +, Maxi color

BEECH



Prima, Classical, Seria +

WHITE

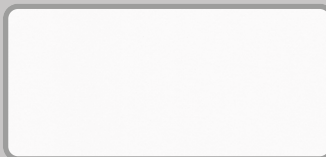

Train, Cubo

HDF (3,2 mm)

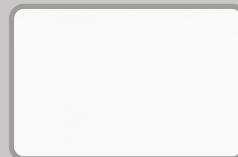

thin shelves

WE USE

LAMINATED CHIPBOARD

HPL LAMINATED CHIPBOARD (18 mm, 25 mm)

25 mm
1 : 1 size



18 mm

1 : 1 size

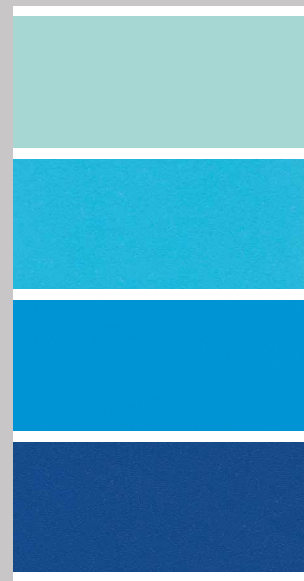
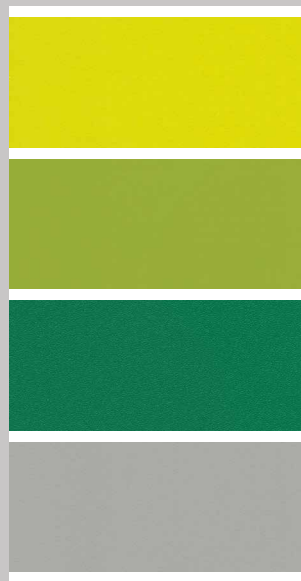
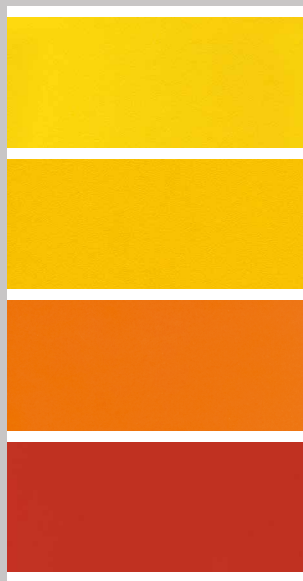

FIRE RETARDANT LAMINATED CHIPBOARD (18 mm)

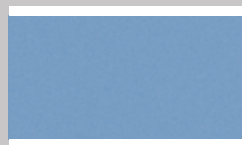

LAMINATED MDF fronts and applications (12 mm), shelves (6 mm)

12 mm



6 mm

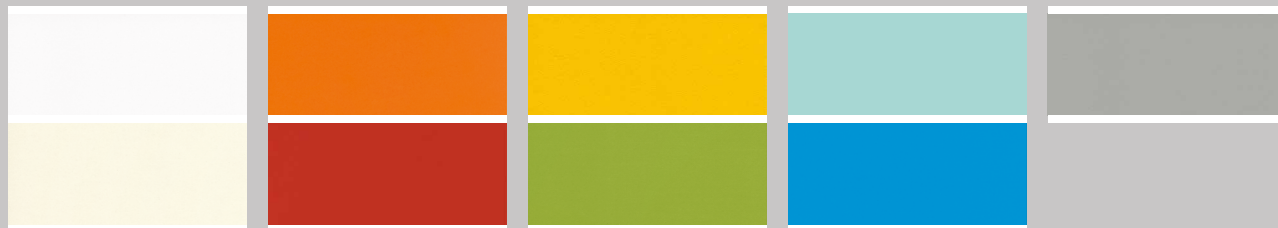
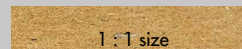

FABRICS



FILLINGS

POLYURETHANE FOAM



Density: R-80



Density: 25 kg/50 m3

HIGH DENSITY AND ELASTICITY OF THE FOAM



FOAM GRANULES



WADDING



POLYSTYRENE GRANULES



METHOD OF SECURING THE STYROFOAM GRANULES

- 1 EXTERNAL PVC FABRIC with zipper for bag replacement
- 2 COTTON BAG with zipper
- 3 POLYSTYRENE FILLING





CERTIFICATION AND ISO

We care about the highest standards of our furniture. The excellent quality of our products is confirmed by international certificates and awards.

ISO Norm 9001 : 2015





This publication is a collection of novelties developed by Nowa Szkoła for 2022 season. We created over 1000 new educational aids, most of them are designed and manufactured by us. The presented offer of items for children includes new versions and colours of our best-selling furniture lines and cloakroom collections, which are in collections with current trends for children. Our teaching materials and soft play are functional, therapeutic and high-quality.

When creating furniture, soft play and pedagogical materials we always put children first. The use of classic white, grey and pastel colours promotes cognitive activity in children and makes the space more peaceful. Light, natural

colours are a safe choice for interior design in various styles. All educational aids, worksheets and lesson scenarios are consulted with methodologists. It makes them well thought out, and as a result, indispensable for teachers in their work.

In that catalogue you will find a reference to the main Nowa Szkoła Export Catalogue 2020 as well as Novelties 2021, which contains the complete offer.

We wish you a successful journey through the amazing world of education.

Nowa Szkoła Team

icons



export 2020 and 2021
page reference



new colours /
product update



with sound



magnetic



printed



quick disinfection

2022 novelities

furniture 10 - 73

activity play 74 - 103

new colours 104 - 107

education 108 - 144



FURNITURE

CLASSICAL

MONOCOLOUR

The Classic collection has been redesigned to keep up with modern trends. The new edition of this furniture line, combined with containers made of wood and cardboard in MONOCOLOUR, gives you the freedom to arrange any interior according to your needs. Thanks to the improved design, the Classic collection offers practical, high-quality furniture with a timeless and elegant form.



STORAGE UNITS 84 WITH CARDBOARD AND WOODEN TRAYS



* Cabinets sold without containers, choose for these models in the next pages which type and colors of containers you prefer.

eko



red



blue



green



yellow



WITH SHALLOW TRAYS

S		M		L		X		XL	
Cardboard	Wooden	Cardboard	Wooden	Cardboard	Wooden	Cardboard	Wooden	Cardboard	Wooden
NW0701-E7	NW0701-G7	NW0702-E7	NW0702-G7	NW0703-E7	NW0703-G7	NW0704-E7	NW0704-G7	NW0705-E7	NW0705-G7
NW0701-E1	NW0701-G1	NW0702-E1	NW0702-G1	NW0703-E1	NW0703-G1	NW0704-E1	NW0704-G1	NW0705-E1	NW0705-G1
NW0701-E2	NW0701-G2	NW0702-E2	NW0702-G2	NW0703-E2	NW0703-G2	NW0704-E2	NW0704-G2	NW0705-E2	NW0705-G2
NW0701-E3	NW0701-G3	NW0702-E3	NW0702-G3	NW0703-E3	NW0703-G3	NW0704-E3	NW0704-G3	NW0705-E3	NW0705-G3
NW0701-E4	NW0701-G4	NW0702-E4	NW0702-G4	NW0703-E4	NW0703-G4	NW0704-E4	NW0704-G4	NW0705-E4	NW0705-G4

WITH DEEP TRAYS

S		M		L		X		XL	
Cardboard	Wooden	Cardboard	Wooden	Cardboard	Wooden	Cardboard	Wooden	Cardboard	Wooden
NW0701-F7	NW0701-H7	NW0702-F7	NW0702-H7	NW0703-F7	NW0703-H7	NW0704-F7	NW0704-H7	NW0705-F7	NW0705-H7
NW0701-F1	NW0701-H1	NW0702-F1	NW0702-H1	NW0703-F1	NW0703-H1	NW0704-F1	NW0704-H1	NW0705-F1	NW0705-H1
NW0701-F2	NW0701-H2	NW0702-F2	NW0702-H2	NW0703-F2	NW0703-H2	NW0704-F2	NW0704-H2	NW0705-F2	NW0705-H2
NW0701-F3	NW0701-H3	NW0702-F3	NW0702-H3	NW0703-F3	NW0703-H3	NW0704-F3	NW0704-H3	NW0705-F3	NW0705-H3
NW0701-F4	NW0701-H4	NW0702-F4	NW0702-H4	NW0703-F4	NW0703-H4	NW0704-F4	NW0704-H4	NW0705-F4	NW0705-H4



STORAGE UNITS 84 WITH CARDBOARD AND WOODEN TRAYS + CONTAINERS ON CASTERS



* Cabinets sold without containers, choose for these models in the next pages which type and colors of containers you prefer.



WITH SHALLOW TRAYS

S		M		L		X		XL	
Cardboard	Wooden	Cardboard	Wooden	Cardboard	Wooden	Cardboard	Wooden	Cardboard	Wooden
NW0801-I7	NW0801-K7	NW0802-I7	NW0802-K7	NW0803-I7	NW0803-K7	NW0804-I7	NW0804-K7	NW0805-I7	NW0805-K7
NW0801-I1	NW0801-K1	NW0802-I1	NW0802-K1	NW0803-I1	NW0803-K1	NW0804-I1	NW0804-K1	NW0805-I1	NW0805-K1
NW0801-I2	NW0801-K2	NW0802-I2	NW0802-K2	NW0803-I2	NW0803-K2	NW0804-I2	NW0804-K2	NW0805-I2	NW0805-K2
NW0801-I3	NW0801-K3	NW0802-I3	NW0802-K3	NW0803-I3	NW0803-K3	NW0804-I3	NW0804-K3	NW0805-I3	NW0805-K3
NW0801-I4	NW0801-K4	NW0802-I4	NW0802-K4	NW0803-I4	NW0803-K4	NW0804-I4	NW0804-K4	NW0805-I4	NW0805-K4

WITH DEEP TRAYS

S		M		L		X		XL	
Cardboard	Wooden	Cardboard	Wooden	Cardboard	Wooden	Cardboard	Wooden	Cardboard	Wooden
NW0801-J7	NW0801-L7	NW0802-J7	NW0802-L7	NW0803-J7	NW0803-L7	NW0804-J7	NW0804-L7	NW0805-J7	NW0805-L7
NW0801-J1	NW0801-L1	NW0802-J1	NW0802-L1	NW0803-J1	NW0803-L1	NW0804-J1	NW0804-L1	NW0805-J1	NW0805-L1
NW0801-J2	NW0801-L2	NW0802-J2	NW0802-L2	NW0803-J2	NW0803-L2	NW0804-J2	NW0804-L2	NW0805-J2	NW0805-L2
NW0801-J3	NW0801-L3	NW0802-J3	NW0802-L3	NW0803-J3	NW0803-L3	NW0804-J3	NW0804-L3	NW0805-J3	NW0805-L3
NW0801-J4	NW0801-L4	NW0802-J4	NW0802-L4	NW0803-J4	NW0803-L4	NW0804-J4	NW0804-L4	NW0805-J4	NW0805-L4

STORAGE UNITS 84 WITH SHELVES



* Cabinets sold without containers, choose for these models in the next pages which type and colors of containers you prefer.

eko



red



blue



green



yellow



WITH SHELVES AND DOORS



S



M



L



X



XL

NW0711-B7	NW0712-B7	NW0713-B7	NW0714-B7	NW0715-B7
NW0711-B1	NW0712-B1	NW0713-B1	NW0714-B1	NW0715-B1
NW0711-B2	NW0712-B2	NW0713-B2	NW0714-B2	NW0715-B2
NW0711-B3	NW0712-B3	NW0713-B3	NW0714-B3	NW0715-B3
NW0711-B4	NW0712-B4	NW0713-B4	NW0714-B4	NW0715-B4

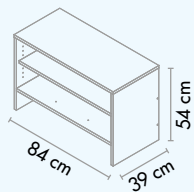

S

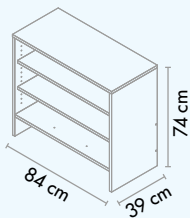

M

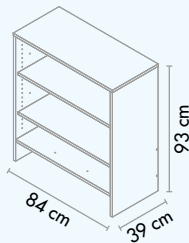

L

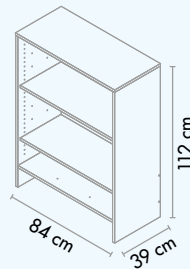

X



XL

STORAGE UNITS 84 WITH SHELVES FOR CONTAINERS



* Cabinets sold without containers, choose for these models in the next pages which type and colors of containers you prefer.



WITH SHELVES AND CONTAINERS

S	M	L	X	XL
NW0811-C7	NW0812-C7	NW0813-C7	NW0814-C7	NW0815-C7
NW0811-C1	NW0812-C1	NW0813-C1	NW0814-C1	NW0815-C1
NW0811-C2	NW0812-C2	NW0813-C2	NW0814-C2	NW0815-C2
NW0811-C3	NW0812-C3	NW0813-C3	NW0814-C3	NW0815-C3
NW0811-C4	NW0812-C4	NW0813-C4	NW0814-C4	NW0815-C4

WITH SHELVES, DOORS AND CONTAINERS

M	L	X	XL
NW0812-D7	NW0813-D7	NW0814-D7	NW0815-D7
NW0812-D1	NW0813-D1	NW0814-D1	NW0815-D1
NW0812-D2	NW0813-D2	NW0814-D2	NW0815-D2
NW0812-D3	NW0813-D3	NW0814-D3	NW0815-D3
NW0812-D4	NW0813-D4	NW0814-D4	NW0815-D4



STORAGE UNITS 84 WITH COMPARTMENTS



S
NW0731



M
NW0732



L
NW0733



X
NW0734



XL
NW0735

STORAGE UNITS 84 WITH COMPARTMENTS FOR CONTAINERS

* Cabinets sold without containers, choose for these models in the next pages which type and colors of containers you prefer.



S
NW0831 *



M
NW0832 *



L
NW0833 *



X
NW0834 *



XL
NW0835 *

STORAGE UNITS 84 WITH COMPARTMENTS AND CONTAINERS



S



M



L



X



XL

NW0831-N1		NW0832-N1		NW0833-N1		NW0834-N1		NW0835-N1
NW0831-N2		NW0832-N2		NW0833-N2		NW0834-N2		NW0835-N2
NW0831-N3		NW0832-N3		NW0833-N3		NW0834-N3		NW0835-N3
NW0831-N4		NW0832-N4		NW0833-N4		NW0834-N4		NW0835-N4

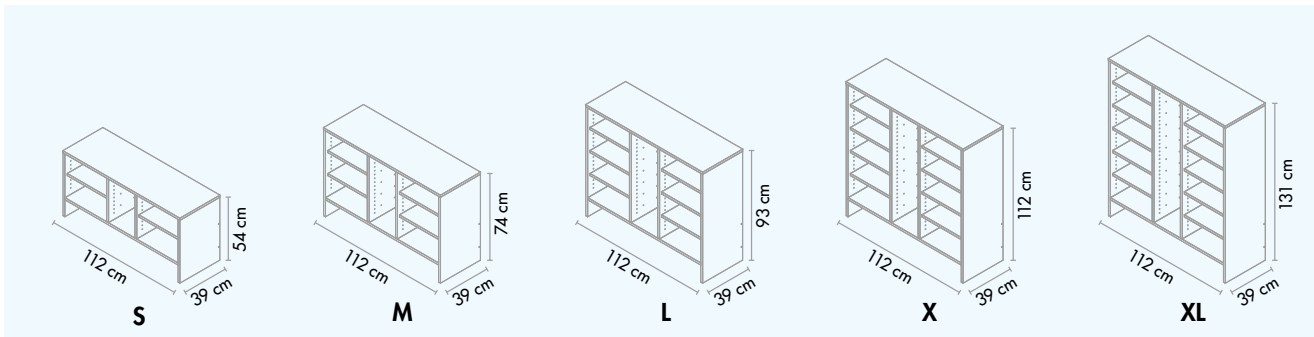

WITH DEEP TRAYS

S		M		L		X		XL	
Cardboard	Wooden	Cardboard	Wooden	Cardboard	Wooden	Cardboard	Wooden	Cardboard	Wooden
NW0721-XF7	NW0721-XH7	NW0722-XF7	NW0722-XH7	NW0723-XF7	NW0723-XH7	NW0724-XF7	NW0724-XH7	NW0725-XF7	NW0725-XH7
NW0721-XF1	NW0721-XH1	NW0722-XF1	NW0722-XH1	NW0723-XF1	NW0723-XH1	NW0724-XF1	NW0724-XH1	NW0725-XF1	NW0725-XH1
NW0721-XF2	NW0721-XH2	NW0722-XF2	NW0722-XH2	NW0723-XF2	NW0723-XH2	NW0724-XF2	NW0724-XH2	NW0725-XF2	NW0725-XH2
NW0721-XF3	NW0721-XH3	NW0722-XF3	NW0722-XH3	NW0723-XF3	NW0723-XH3	NW0724-XF3	NW0724-XH3	NW0725-XF3	NW0725-XH3
NW0721-XF4	NW0721-XH4	NW0722-XF4	NW0722-XH4	NW0723-XF4	NW0723-XH4	NW0724-XF4	NW0724-XH4	NW0725-XF4	NW0725-XH4

WITH DEEP TRAYS AND DOORS

S		M		L		X		XL	
Cardboard	Wooden	Cardboard	Wooden	Cardboard	Wooden	Cardboard	Wooden	Cardboard	Wooden
NW0721-ZF7	NW0721-ZH7	NW0722-ZF7	NW0722-ZH7	NW0723-ZF7	NW0723-ZH7	NW0724-ZF7	NW0724-ZH7	NW0725-ZF7	NW0725-ZH7
NW0721-ZF1	NW0721-ZH1	NW0722-ZF1	NW0722-ZH1	NW0723-ZF1	NW0723-ZH1	NW0724-ZF1	NW0724-ZH1	NW0725-ZF1	NW0725-ZH1
NW0721-ZF2	NW0721-ZH2	NW0722-ZF2	NW0722-ZH2	NW0723-ZF2	NW0723-ZH2	NW0724-ZF2	NW0724-ZH2	NW0725-ZF2	NW0725-ZH2
NW0721-ZF3	NW0721-ZH3	NW0722-ZF3	NW0722-ZH3	NW0723-ZF3	NW0723-ZH3	NW0724-ZF3	NW0724-ZH3	NW0725-ZF3	NW0725-ZH3
NW0721-ZF4	NW0721-ZH4	NW0722-ZF4	NW0722-ZH4	NW0723-ZF4	NW0723-ZH4	NW0724-ZF4	NW0724-ZH4	NW0725-ZF4	NW0725-ZH4

STORAGE UNITS 112 WITH CARDBOARD AND WOODEN TRAYS



* Cabinets sold without containers, choose for these models in the next pages which type and colors of containers you prefer.



WITH SHALLOW TRAYS

S		M		L		X		XL	
Cardboard	Wooden	Cardboard	Wooden	Cardboard	Wooden	Cardboard	Wooden	Cardboard	Wooden
NW0721-XE7	NW0721-XG7	NW0722-XE7	NW0722-XG7	NW0723-XE7	NW0723-XG7	NW0724-XE7	NW0724-XG7	NW0725-XE7	NW0725-XG7
NW0721-XE1	NW0721-XG1	NW0722-XE1	NW0722-XG1	NW0723-XE1	NW0723-XG1	NW0724-XE1	NW0724-XG1	NW0725-XE1	NW0725-XG1
NW0721-XE2	NW0721-XG2	NW0722-XE2	NW0722-XG2	NW0723-XE2	NW0723-XG2	NW0724-XE2	NW0724-XG2	NW0725-XE2	NW0725-XG2
NW0721-XE3	NW0721-XG3	NW0722-XE3	NW0722-XG3	NW0723-XE3	NW0723-XG3	NW0724-XE3	NW0724-XG3	NW0725-XE3	NW0725-XG3
NW0721-XE4	NW0721-XG4	NW0722-XE4	NW0722-XG4	NW0723-XE4	NW0723-XG4	NW0724-XE4	NW0724-XG4	NW0725-XE4	NW0725-XG4

WITH SHALLOW TRAYS

S		M		L		X		XL	
Cardboard	Wooden	Cardboard	Wooden	Cardboard	Wooden	Cardboard	Wooden	Cardboard	Wooden
NW0721-ZE7	NW0721-ZG7	NW0722-ZE7	NW0722-ZG7	NW0723-ZE7	NW0723-ZG7	NW0724-ZE7	NW0724-ZG7	NW0725-ZE7	NW0725-ZG7
NW0721-ZE1	NW0721-ZG1	NW0722-ZE1	NW0722-ZG1	NW0723-ZE1	NW0723-ZG1	NW0724-ZE1	NW0724-ZG1	NW0725-ZE1	NW0725-ZG1
NW0721-ZE2	NW0721-ZG2	NW0722-ZE2	NW0722-ZG2	NW0723-ZE2	NW0723-ZG2	NW0724-ZE2	NW0724-ZG2	NW0725-ZE2	NW0725-ZG2
NW0721-ZE3	NW0721-ZG3	NW0722-ZE3	NW0722-ZG3	NW0723-ZE3	NW0723-ZG3	NW0724-ZE3	NW0724-ZG3	NW0725-ZE3	NW0725-ZG3
NW0721-ZE4	NW0721-ZG4	NW0722-ZE4	NW0722-ZG4	NW0723-ZE4	NW0723-ZG4	NW0724-ZE4	NW0724-ZG4	NW0725-ZE4	NW0725-ZG4

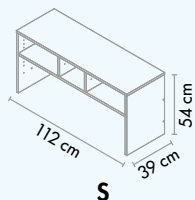

S

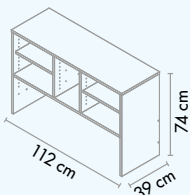

M

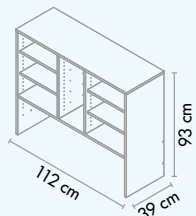

L

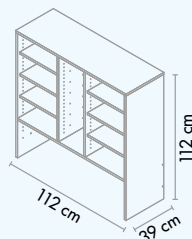

X

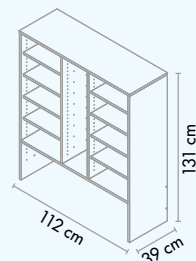

XL

WITH DEEP TRAYS AND CONTAINERS



S



M



L



X



XL

Cardboard

Wooden

Cardboard

Wooden

Cardboard

Wooden

Cardboard

Wooden

Cardboard

Wooden

NW0821-XJ7	NW0821-XL7	NW0822-XJ7	NW0822-XL7	NW0823-XJ7	NW0823-XL7	NW0824-XJ7	NW0824-XL7	NW0825-XJ7	NW0825-XL7
NW0821-XJ1	NW0821-XL1	NW0822-XJ1	NW0822-XL1	NW0823-XJ1	NW0823-XL1	NW0824-XJ1	NW0824-XL1	NW0825-XJ1	NW0825-XL1
NW0821-XJ2	NW0821-XL2	NW0822-XJ2	NW0822-XL2	NW0823-XJ2	NW0823-XL2	NW0824-XJ2	NW0824-XL2	NW0825-XJ2	NW0825-XL2
NW0821-XJ3	NW0821-XL3	NW0822-XJ3	NW0822-XL3	NW0823-XJ3	NW0823-XL3	NW0824-XJ3	NW0824-XL3	NW0825-XJ3	NW0825-XL3
NW0821-XJ4	NW0821-XL4	NW0822-XJ4	NW0822-XL4	NW0823-XJ4	NW0823-XL4	NW0824-XJ4	NW0824-XL4	NW0825-XJ4	NW0825-XL4

WITH DEEP TRAYS, DOORS AND CONTAINERS



M



L



X



XL

Cardboard

Wooden

Cardboard

Wooden

Cardboard

Wooden

Cardboard

Wooden

		NW0822-ZJ7	NW0822-ZL7	NW0823-ZJ7	NW0823-ZL7	NW0824-ZJ7	NW0824-ZL7	NW0825-ZJ7	NW0825-ZL7
		NW0822-ZJ1	NW0822-ZL1	NW0823-ZJ1	NW0823-ZL1	NW0824-ZJ1	NW0824-ZL1	NW0825-ZJ1	NW0825-ZL1
		NW0822-ZJ2	NW0822-ZL2	NW0823-ZJ2	NW0823-ZL2	NW0824-ZJ2	NW0824-ZL2	NW0825-ZJ2	NW0825-ZL2
		NW0822-ZJ3	NW0822-ZL3	NW0823-ZJ3	NW0823-ZL3	NW0824-ZJ3	NW0824-ZL3	NW0825-ZJ3	NW0825-ZL3
		NW0822-ZJ4	NW0822-ZL4	NW0823-ZJ4	NW0823-ZL4	NW0824-ZJ4	NW0824-ZL4	NW0825-ZJ4	NW0825-ZL4

STORAGE UNITS 112 WITH TRAYS AND CONTAINERS



* Cabinets sold without containers, choose for these models in the next pages which type and colors of containers you prefer.



WITH SHALLOW TRAYS AND CONTAINERS

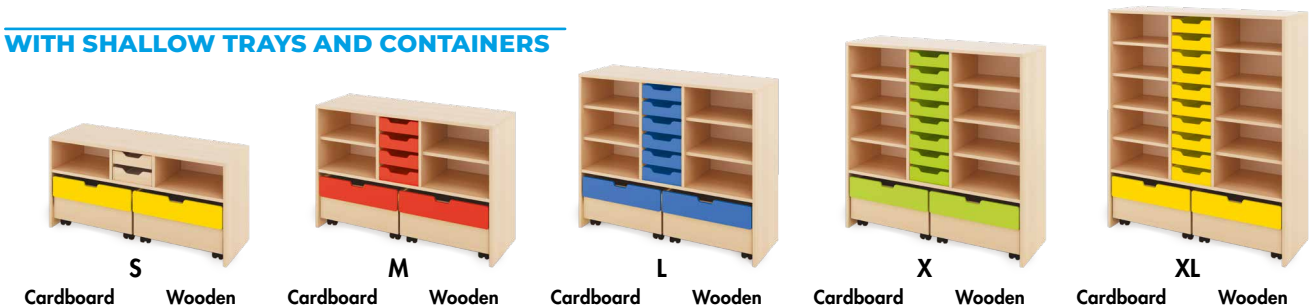

S		M		L		X		XL	
Cardboard	Wooden	Cardboard	Wooden	Cardboard	Wooden	Cardboard	Wooden	Cardboard	Wooden
NW0821-X17	NW0821-XK7	NW0822-X17	NW0822-XK7	NW0823-X17	NW0823-XK7	NW0824-X17	NW0824-XK7	NW0825-X17	NW0825-XK7
NW0821-X11	NW0821-XK1	NW0822-X11	NW0822-XK1	NW0823-X11	NW0823-XK1	NW0824-X11	NW0824-XK1	NW0825-X11	NW0825-XK1
NW0821-X12	NW0821-XK2	NW0822-X12	NW0822-XK2	NW0823-X12	NW0823-XK2	NW0824-X12	NW0824-XK2	NW0825-X12	NW0825-XK2
NW0821-X13	NW0821-XK3	NW0822-X13	NW0822-XK3	NW0823-X13	NW0823-XK3	NW0824-X13	NW0824-XK3	NW0825-X13	NW0825-XK3
NW0821-X14	NW0821-XK4	NW0822-X14	NW0822-XK4	NW0823-X14	NW0823-XK4	NW0824-X14	NW0824-XK4	NW0825-X14	NW0825-XK4

WITH SHALLOW TRAYS, DOORS AND CONTAINERS

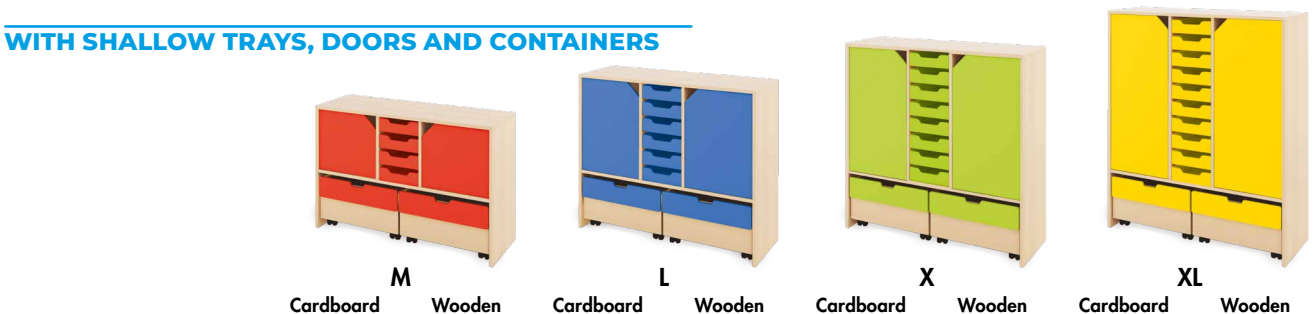

M		L		X		XL		
Cardboard	Wooden	Cardboard	Wooden	Cardboard	Wooden	Cardboard	Wooden	
	NW0822-Z17	NW0822-ZK7	NW0823-Z17	NW0823-ZK7	NW0824-Z17	NW0824-ZK7	NW0825-Z17	NW0825-ZK7
	NW0822-Z11	NW0822-ZK1	NW0823-Z11	NW0823-ZK1	NW0824-Z11	NW0824-ZK1	NW0825-Z11	NW0825-ZK1
	NW0822-Z12	NW0822-ZK2	NW0823-Z12	NW0823-ZK2	NW0824-Z12	NW0824-ZK2	NW0825-Z12	NW0825-ZK2
	NW0822-Z13	NW0822-ZK3	NW0823-Z13	NW0823-ZK3	NW0824-Z13	NW0824-ZK3	NW0825-Z13	NW0825-ZK3
	NW0822-Z14	NW0822-ZK4	NW0823-Z14	NW0823-ZK4	NW0824-Z14	NW0824-ZK4	NW0825-Z14	NW0825-ZK4

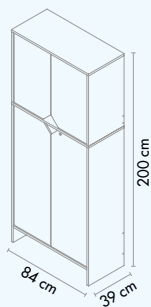
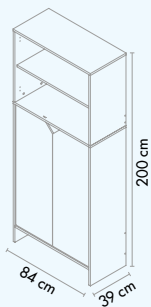

WITH DOORS XL



 NW8010-8



 NW8010-1

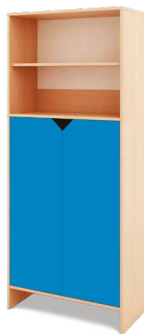

 NW8010-2



 NW8010-3



 NW8010-4

WITH DOORS ADD-ON AND XL



 NW8020-8



 NW8020-1



 NW8020-2



 NW8020-3



 NW8020-4

TALL STORAGE



NW8004

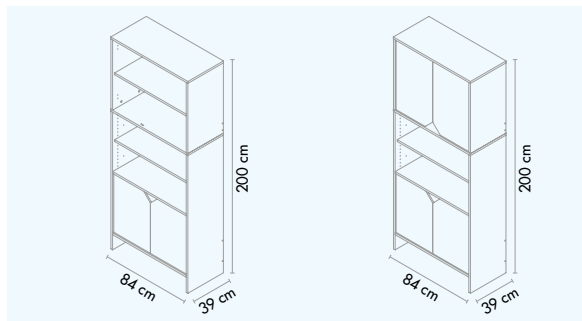

WITH DOORS M



NW8021-8



NW8021-1



NW8021-2



NW8021-3



NW8021-4

WITH DOORS ADD-ON AND M



NW8022-8



NW8022-1



NW8022-2



NW8022-3



NW8022-4

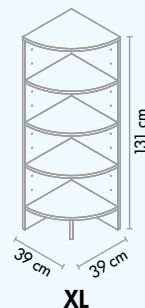
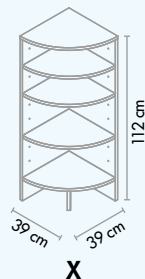
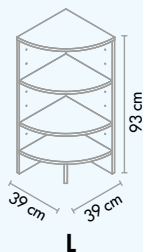
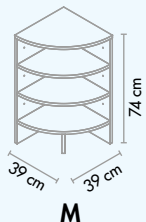
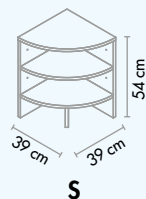

INSIDE CORNER SHELVING UNIT



S

NW0761



M

NW0762



L

NW0763



X

NW0764



XL

NW0765

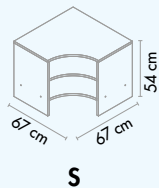

S

NW0751

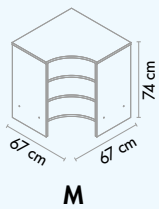

M

NW0752

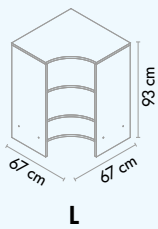

L

NW0753

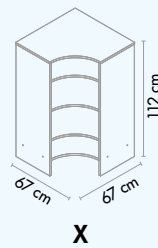

X

NW0754

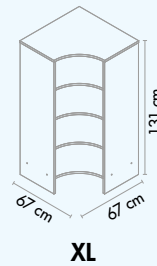

XL

NW0755

CORNER SHELVING UNIT



S

NW0751



M

NW0752



L

NW0753



X

NW0754



XL

NW0755

CONTAINERS



M



L

	NK0621		NK0611
	NK0622		NK0612
	NK0623		NK0613
	NK0624		NK0614

TRAYS



Wooden Beech



Wooden Poplar

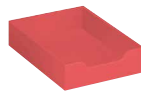

Cardboard



Cardboard ECO



Wooden Beech		Wooden Poplar		Cardboard		Cardboard ECO	
Shallow	Deep	Shallow	Deep	Shallow	Deep	Shallow	Deep
NS7930	NS7910	NS7730	NS7710	-	-	NS0717	NS0718
NS7931	NS7911	NS7731	NS7711	NS1714	NS1715	-	-
NS7932	NS7912	NS7732	NS7712				
NS7933	NS7913	NS7733	NS7713				
NS7934	NS7914	NS7734	NS7714				

CUBO

CANOPIES





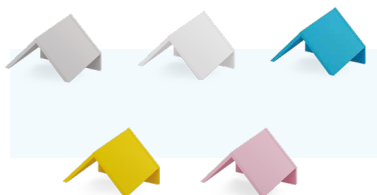
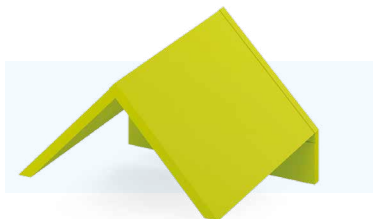

Canopies combining functionality and style for the Cubo line furniture. They are perfect for designing interesting and practical interiors which encourage fun and learning.

The canopies are available in six colours and three sizes and can be attached to all Cubo units.

UNIT 1

- canopy, dim.: 39 x 32 x 19,6 cm;
- type: add-on; available in grey, white, lime, teal, yellow, rosy colours,
- 18 mm thick









	NC6112
	NC6113
	NC6114
	NC6115
	NC6116
	NC6117

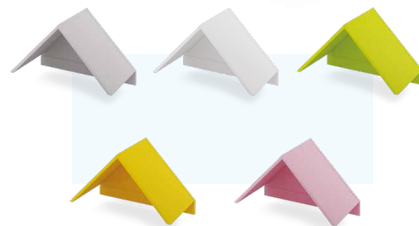

UNIT 2

- canopy with 1 niche,
- dim.: 76 x 35 x 38 cm;
- type: add-on; it is made of grey, white, lime, teal, yellow, rosy chipboard,
- 18 mm thick







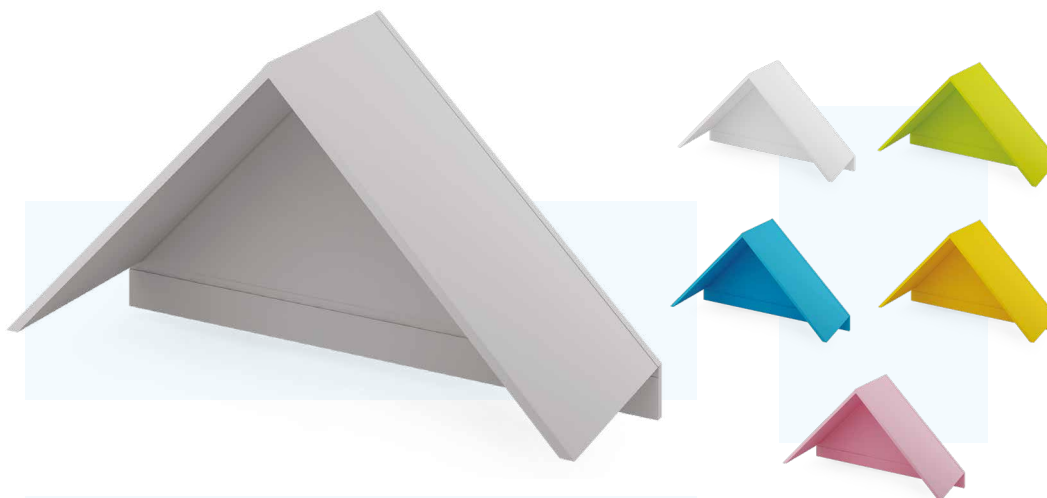

	NC6212
	NC6213
	NC6214
	NC6215
	NC6216
	NC6217





UNIT 3

- canopy with 1 niche,
- dim.: 114 x 40 x 57 cm;
- type: add-on; it is made of grey, white, lime, teal, yellow, rosy chipboard,
- 18 mm thick

	NC6312
	NC6313
	NC6314
	NC6315
	NC6316
	NC6317

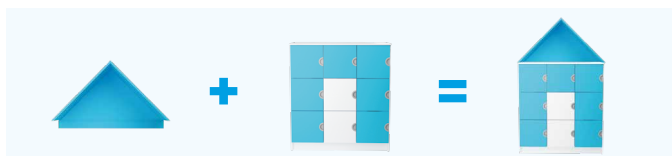

CUBO

FURNITURE FOR PLASTIC TRAYS

CABINETS

- type: standalone; it is made of 18 mm thick chipboard in birch colour, dim.: 32,1 x 41,1 cm, made of 18 mm thick birch-coloured chipboard; possible equipment (sold separately): containers



trays are available
on page 30

Cubo cabinets for plastic trays. They allow you to create storage space in an ergonomic way. The containers can be adjusted to fit the individual needs of users while the cabinets make for an interesting part of the interior design.

CABINETS FOR PLASTIC TRAYS
ARE 5 CM DEEPER THAN
STANDARD CUBO CABINETS

SMALL



Cubo cabinet 1 for plastic trays.

Birch

NC1191

- dim.: 36 x 45 x 50 cm



Cubo cabinet 2 for plastic trays.

Birch

NC2191

- dim.: 70 x 45 x 50 cm



Cubo cabinet 3 for plastic trays.

Birch

NC3191

- dim.: 104 x 45 x 50 cm

MEDIUM



Cubo cabinet 2 for plastic trays.

Birch

NC1291

- dim.: 36 x 45 x 87 cm



Cubo cabinet 4 for plastic trays.

Birch

NC2291

- dim.: 70 x 45 x 87 cm



Cubo cabinet 6 for plastic trays.

Birch

NC3291

- dim.: 104 x 45 x 87 cm

TALL



Cubo cabinet 1 for plastic trays.

Birch

NC1391

- dim.: 36 x 45 x 125 cm



Cubo cabinet 6 for plastic trays.

Birch

NC2391

- dim.: 70 x 45 x 125 cm



Cubo cabinet 9 for plastic trays.

Birch

NC3391

- dim.: 104 x 45 x 125 cm









PLASTIC TRAYS

Plastic containers for the Cubo line furniture. They are perfect for implementing creative storage ideas. The wide selection of colours and sizes allows you to create unique

arrangements which can be easily modified at any time. All containers are made of durable material.

MAXI

- dim.: 31 x 42 x 30 cm, in the shape of a rectangle; material: plastic; assemblage method: plastic runners included in the set; intended use: storage





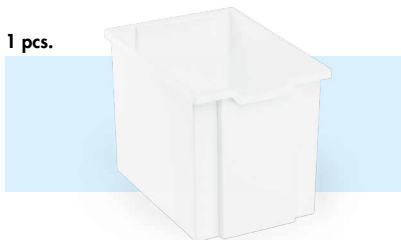

	NS2348
	NS2349
	NS2350
	NS2351
	NS2352
	NS2353

1 pcs.



DEEP

- dim.: 31 x 42 x 16 cm, in the shape of a rectangle; material: plastic; assemblage method: plastic runners included in the set; intended use: storage





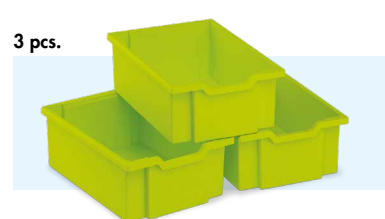

	NS2356
	NS2357
	NS2358
	NS2359
	NS2331
	NS2330

3 pcs.









SHALLOW

- dim.: 31 x 42 x 7 cm, in the shape of a rectangle; material: plastic; assemblage method: plastic runners included in the set; intended use: storage

	NS2368
	NS2369
	NS2370
	NS2371
	NS2335
	NS2334







6 pcs.



	NS2360
	NS2361
	NS2362
	NS2363
	NS2333
	NS2332







4 pcs.



	NS2372
	NS2373
	NS2374
	NS2375
	NS2339
	NS2338

8 pcs.



	NS2364
	NS2365
	NS2366
	NS2367
	NS2337
	NS2336

6 pcs.



CABINETS FOR PLASTIC TRAYS
ARE 5 CM DEEPER THAN
STANDARD CUBO CABINETS



CUBO

BEDDING CABINET

Cubo bed cabinet designed with the sleeping or lounging space in mind. Thanks to the wide selection of accessories in different colours, you can adjust your furniture piece so that it perfectly fits into the interior.

CABINET

Bed Cabinet NS2845

- wardrobe, dim.: 141 x 61 x 120 cm; type: standalone; it is made of 18 mm thick chipboard in birch colour; it is possible to buy additional equipment doors and curtain; the back is made of white MDF board, 3 mm thick



ADD ON

Bed and Bedding Cabinet NS2846

- wardrobe with 16 niches, dim.: 141 x 61 x 198,5 cm; type: standalone; it is made of 18 mm thick chipboard in birch colour; the wardrobe has 12 shelves made of MDF board, 6 mm thick, in white colour. it is possible to buy additional equipment: doors and curtain; the back is made of white MDF board, 3 mm thick



DOORS

	NC5102
	NC5103
	NC5104
	NC5105
	NC5106
	NC5107

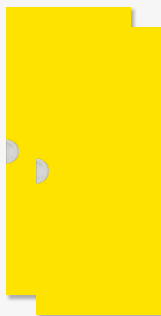

DOORS

	NC5002
	NC5003
	NC5004
	NC5005
	NC5006
	NC5007

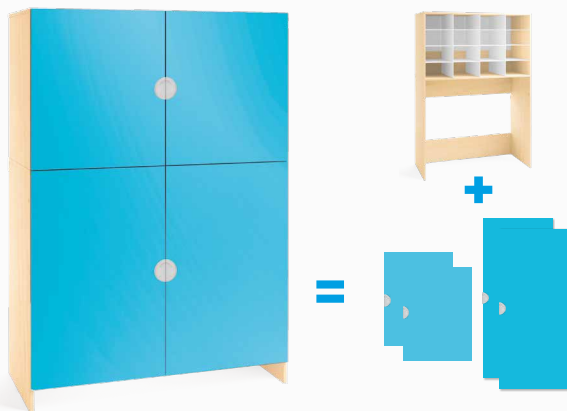
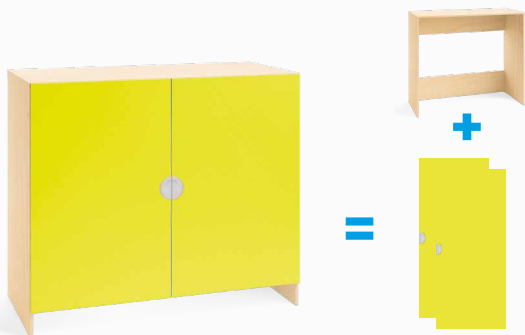
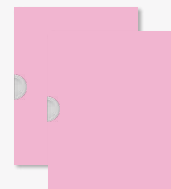



CHANGING UNIT

If you combine the presented elements from the Cubo line, you can create a changing unit which is unique and safe for the little ones. The mattresses available in different colours allow you to customise the piece of furniture in order to match it your interior.



Cubo Changing Unit
NC0300

- changing unit on socle with 4 niches, dim.: 77 x 74,5 x 100 cm; type: standalone; it is made of 18 mm thick chipboard in birch colour



drawers available
in export catalogue 2020



Add-in for the Cubo Changing Unit
NC0302

- add-on with 3 niches; type: add-on; it is made of birch-coloured chipboard, 18 mm thick; 3 shelves made of 18 mm thick chipboard, dim.: 13 x 16,6 cm, in birch colour



STAIRS FOR CHANGING UNIT

Stairs with railings designed for the Cubo changing unit (NC0300). They allow children to step right up on their own. While this solution gives a chance for toddlers to train their skill of climbing the stairs, it facilitates the work of caregivers.

- dimensions: 49,2 x 70 x 85 cm; 4 steps; material: sides made of MDF board, 12 mm thick, in white; stairs made of chipboard, 18 mm thick



- Blue
NC0303



- Birch
NC0304



ERGONOMIC MATTRESS FOR THE CUBO CHANGING TABLE

- dim.: 50 x 70 x 15 cm; the cover is made of PCV; filling: polyurethane foam;
- additional information: suitable for Cubo changing unit NCO300



Grey
NS3272



White
NS3273



Marine
NS3275

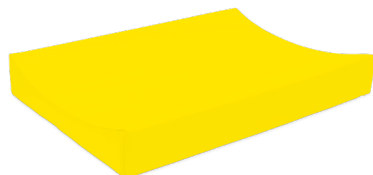

Yellow
NS3276



Lemon grass
NS3274



Pink
NS3277

FANTASY

FORREST

ON THE SOCLE

Children love animals and they like to watch and play with them. To meet their needs, we present a new, fairy-tale collection of furniture-the Fantasy line. The whole line consists of the same furniture modules differing only by decorations and prints on the fronts. The Forest line has been additionally enriched with the teacher's desk. The furniture is perfect for furnishing nurseries and kindergarten rooms; they create a functional space and help to organise the children's activities. The wide selection of modules allows you to freely arrange the interiors to make them suitable for the little ones. Their universal colour palette acts as a background for different elements and decorations. All furniture pieces can be purchased in a set or separately.



Trees cabinet

NS2582

- dim.: 82 x 38 x 166 cm,
- with a decoration: 224 cm high



Owl cabinet

NS2583

- dim.: 41 x 38 x 166 cm



Bear cabinet

NS2580

- dim.: 82 x 38 x 84 cm,
- with a decoration: 127 cm high



Small squirrel cabinet

NS2581

- dim.: 41 x 38 x 125 cm,
- with a decoration: 162 cm high



Fir trees cabinet

NS2584

- dim.: 82 x 38 x 84 cm,
- with a decoration: 122 cm high



Cabinet with sliding doors
NS2585

- dim.: 82 x 38 x 84 cm,
- with a decoration: 128 cm high

Cabinet with compartments
NS2586

- dim.: 82 x 38 x 84 cm

Woodpecker desk
NS2587

- dim.: 120 x 51,2 x 76,5 cm

Deer container
NS2588

- dim.: 82 x 38 x 43 cm
- with a decoration: 148 cm high

Fox cabinet
NS2589

- dim.: 82 x 38 x 84 cm



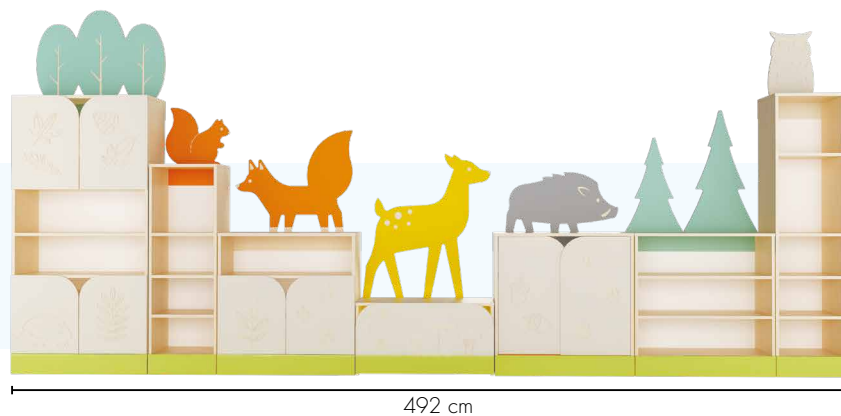

Forest. Set 1
NS2590

total length 492 cm

- NS2582
- NS2581
- NS2589
- NS2588
- NS2585
- NS2584
- NS2583

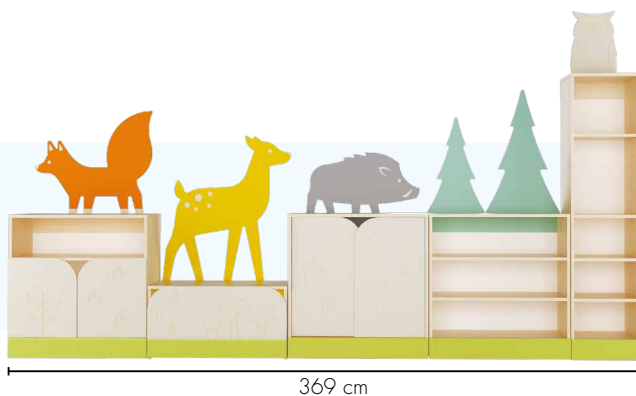

Forest. Set 2
NS2591

total length 369 cm

- NS2589
- NS2588
- NS2585
- NS2584
- NS2583

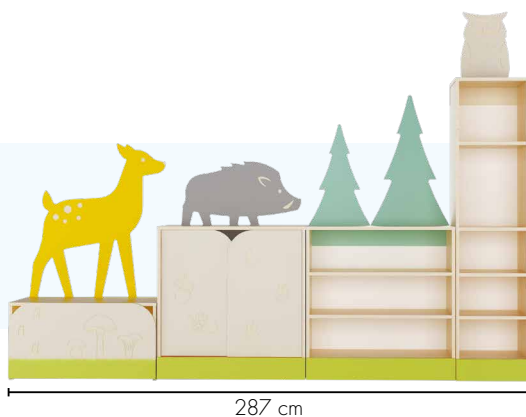

Forest. Set 3
NS2592

total length 287 cm

- NS2588
- NS2585
- NS2584
- NS2583



WITH LEGS



Bear cabinet
FN2580

- dim.: 82 x 38 x 84 cm,
- with a decoration: 162 cm high



Small squirrel cabinet
FN2581

- dim.: 41 x 37 x 125 cm,
- with a decoration: 223 cm high



Deer container
FN2588

- dim.: 82 x 38 x 43 cm
- with 148 cm high decoration



Fox cabinet
FN2589

- dim.: 82 x 38 x 84 cm



Fir trees cabinet
FN2584

- dim.: 82 x 37 x 84 cm,
- with a decoration: 120,8 cm high



Cabinet with sliding doors
FN2585

- dim.: 82 x 37 x 84 cm,
- with a decoration: 127 cm high



Cabinet with compartments
FN2586

- dim.: 82 x 38 x 84 cm,
- with a decoration: 133 cm high



Woodpecker desk
NS2587

- dim.: 120 x 51,2 x 76,5 cm



Trees cabinet
FN2582

- dim.: 82 x 37 x 166 cm,
- with a decoration: 208 cm high



Owl cabinet
FN2583

- dim.: 41 x 37 x 166 cm

FORREST



SHELVES



Hedgehog. Wall shelf

NS2593

- dim.: 41 x 16 cm

CARPETS



**Forest.
Fantasy polyamide carpet**
MU0005

Big carpet "Forest" perfect for nurseries and kindergartens. This product will complement any interior as well as create space for relaxation

or playtime. The fabric is resistant to abrasion. It also has anti-microbial and anti-mould properties. The carpet is easy to clean.

- colours do not fade; fabric: polyamide yarn;
dim.: 400 x 300 cm

MANIPULATIVE BOARDS



Forest. Manipulative board

NS9090

- manipulation board, forest themed; it is equipped with 3 movable elements, 4 elements

with texture and 1 rotating element; the board is made of MDF board with a UV print;
dim.: 130 x 79 cm



FARM



Farm Collection
available in export
catalogue 2020

SHELVES



Tractor. Wall shelf
NS2859

• dim.: 41 x 16 cm

DESKS



Goose desk
NS2860

• dim.: 120 x 51 x 77 cm

CARPETS

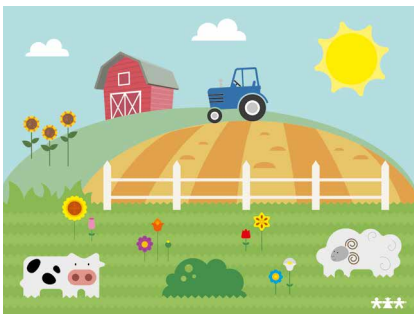

Farm. Fantasy polyamide carpet
MU0002

Big carpet "Farm" perfect for nurseries and kindergartens. This product will complement any interior as well as create space for relaxation or playtime.

The fabric is resistant to abrasion. It also has anti-microbial and anti-mould properties. The carpet is easy to clean.

- colours do not fade; fabric: polyamide yarn;
dim.: 400 x 300 cm

MANIPULATIVE BOARDS



Farm. Manipulative board
NS9068

- manipulation board, farm themed; it is equipped with 2 movable elements, 3 elements

with texture and 1 rotating element; the board is made of MDF board with a print;
dim.: 130 x 79 cm



JUNGLE

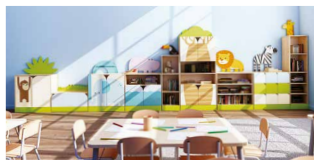

Jungle Collection
available in export
catalogue 2020

SHELVES



Gorilla. Wall shelf

NS2810

- dim.: 41 x 16 cm

ROYAL



Royal Collection
available in export
catalogue 2020

SHELVES



Castle. Wall shelf

NS2884

- dim.: 44 x 16 cm

DESKS



Unicorn desk

NS2880

- dim.: 120 x 51 x 77 cm

CARPETS



Royal. Fantasy polyamide carpet
MU0004

Big carpet "Royal" perfect for nurseries and kindergartens. This product will complement any interior as well as create space for relaxation or playtime. The

fabric is resistant to abrasion. It also has anti-microbial and anti-mould properties. The carpet is easy to clean.

- colours do not fade; fabric: polyamide yarn; dim.: 400 x 300 cm



MANIPULATIVE BOARDS



Royal. Manipulative board

NS9092

- manipulation board, kingdom themed; it is equipped with 1 movable element, 6 ele-

ments with texture and 4 rotating elements; the board is made of MDF board with a print; dim.: 130 x 79 cm

WAVE



SHELVES



Wave Collection
available in export
catalogue 2020



Jellyfish. Wall shelf
NS2877

• dim.: 46 x 16 cm

DESKS



Crab desk

NS2870

• dim.: 120 x 51 x 76,5 cm

CARPETS



Wave. Fantasy polyamide carpet
MU0003

Big carpet "Wave" perfect for nurseries and kindergartens. This product will complement any interior as well as create space for relaxation or playtime. The

fabric is resistant to abrasion. It also has anti-microbial and anti-mould properties. The carpet is easy to clean.

- colours do not fade; fabric: polyamide yarn; dim.: 400 x 300 cm



MANIPULATIVE BOARDS



Wave. Manipulative board

NS9091

- manipulation board, sea themed; it is equipped with 2 movable elements, 2 ele-

ments with texture, 1 mirror, 3 Velcro elements and 1 plexi rotating element; the board is made of MDF board with a print; dim.: 130 x 79 cm

MINTY

STORAGE UNIT WITH DRAWERS



minty is available
in export catalogue 2020

Minty collection in bright, pastel colours. It combines functionality and aesthetics. The eye pleasing colours of the collection allow you to create a friendly atmosphere for fun and learning.



Minty. Narrow chest of 3 drawers
NS3231

- dim.: 50 x 41 x 77 cm



Minty. Wide chest of 3 drawers
NS3232

- dim.: 100 x 41 x 77 cm
- each drawer with compartment



DECORATIVE BOARDS



Minty. Shrub wall decoration

NS3237

- dim.: 98 x 55 cm

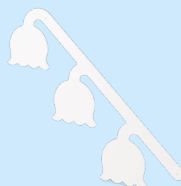

Minty. Lily of the valley wall decoration

NS3239

- dim.: 39,5 x 119 cm

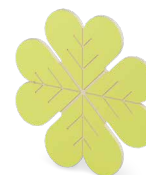

Minty. Clover wall decoration

NS3238

- dim.: 45 x 45 cm

PRIMA

UNIT FOR MAPS

Map storage cabinets complete the Prima furniture line. They provide functional storage space for maps and protect them from accidental damage. Thanks to the presented furniture pieces, it is possible to create a classroom which caters to the needs of students and teachers.

- dim.: 90 x 40 x 190,5 cm; with 4 niches; type: standalone; it is made of 18 mm thick chipboard; the wardrobe on a socle with 3 shelves, dim.: 86,5 x 39 cm, made of 18 mm thick chipboard/MDF board; four doors, dim.: 45 x 105,5/70 cm, made of 18 mm thick chipboard; smooth surface; plastic handle; doors with a lock; storage space for 12 maps



**- birch
NB2901**



**- beech
NB2902**



**- white birch
NB2903**



**- white beech
NB2904**

EXCLUSIVE LINE





Modern furniture collection ideal for creating any workspace in educational institutions. The furniture's system helps to arrange headmaster's office and secretariats functionally and aesthetically. This collection is also well suited for arranging open or regular office spaces and conference rooms. Practical desks with storage space for documents and other accessories ensure optimal working conditions. They are equipped with several innovative solutions which allow users to adjust them to individual preferences and the nature of work. Reception desks char-

acterised by simple construction and sweeping forms endow elegant and welcoming interiors. A perfect addition to every office is a round coffee table which is also available in our offer. For storing, we recommend spacious chests of drawers, cabinets and two-door wardrobes. This solid furniture line was made of durable chipboard, 18 and 25 mm thick. Simple shapes and versatile colours inspired by natural birch wood combined with subtle white fronts bring harmony into the interior, stimulate creativity and favour decision-making.



FRAME

chipboard
thick 25 mm
colour birch 
base: chipboard

DOOR

chipboard
thick 18 mm
smooth surface
colour  
no lock

SHELVES

chipboard
thick 25 mm
colour birch 
board MDF
thick 6 i 12 mm
colour white 

HANDLES

aluminum handles



CHEST FOR DRAWERS

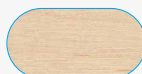

Chest of drawers. Birch

EXC1291

- dim.: 85,5 x 45,5 x 77 cm; 4 shelves; material: frame made of chipboard, 25 mm thick, in birch colour, drawer fronts made of chipboard, 18 mm thick, in birch colour

Maxi chest of drawers. Birch

EXC2291

- dim.: 168 x 45,5 x 77 cm; 8 shelves; material: frame made of chipboard, 25 mm thick, in birch colour, drawer fronts made of chipboard, 18 mm thick, in birch colour



Chest of drawers. Birch and white

EXC1293

- dim.: 85,5 x 45,5 x 77 cm; 4 shelves; material: frame made of chipboard, 25 mm thick, in birch colour, drawer fronts made of chipboard, 18 mm thick, in white colour

Maxi chest of drawers. Birch and white

EXC2293

- dim.: 168 x 45,5 x 77 cm; 8 shelves; material: frame made of chipboard, 25 mm thick, in birch colour, drawer fronts made of chipboard, 18 mm thick, in white colour



CABINETS

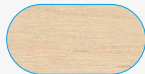

Wardrobe. Birch

EXC1661

- dim.: 85,5 x 45,5 x 210 cm; two-door wardrobe equipped with a rod and a shelf; material: frame made of chipboard, 25 mm thick, in birch colour, doors made of chipboard, 18 mm thick, in birch colour

Medium cabinet with a pair of doors. Birch

EXC1431

- dim.: 85,5 x 45,5 x 143,5 cm; an open shelf, 3 shelves with a pair of doors; material: frame made of chipboard, 25 mm thick, in birch colour, doors made of chipboard, 18 mm thick, in birch colour



Tall cabinet. Birch

EXC1601

- dim.: 85,5 x 45,5 x 210 cm; 6 open shelves; material: chipboard, 25 mm thick, in birch colour



Wardrobe - birch and white

EXC1663

- dim.: 85,5 x 45,5 x 210 cm; two-door wardrobe equipped with a rod and a shelf; material: frame made of chipboard, 25 mm thick, in birch colour, doors made of chipboard, 18 mm thick, in white colour

Medium cabinet with a pair of doors.

Birch and white

EXC1433

- dim.: 85,5 x 45,5 x 143,5 cm; an open shelf, 3 shelves with a pair of doors; material: frame made of chipboard, 25 mm thick, in birch colour, doors made of chipboard, 18 mm thick, in white colour



SHELVES

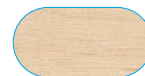

Hanging shelf. Birch

EXC3101

- dim.: 85,5 x 35,5 x 36 cm; material: chipboard, 25 mm thick, in birch colour

RECEPTION DESKS



Reception desk. Birch
EXC9001

- dim.: 183,5 x 183,5 x 119 cm; 2 containers with 3 drawers, 4 dividers; material: frame made of chipboard, 25 mm thick, in birch colour, tabletop made of chipboard, 25 mm thick, in birch colour, dividers, drawer fronts and socles are made of chipboard, 18 mm thick, in birch colour



Reception desk. Birch and white
EXC9003

- dim.: 183,5 x 183,5 x 119 cm; 2 containers with 3 drawers, 4 dividers; material: frame made of chipboard, 25 mm thick, in birch and white colour, tabletop made of chipboard, 25 mm thick, in birch colour, dividers, drawer fronts and socles are made of chipboard, 18 mm thick, in white colour

DESKS

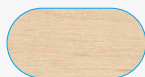

Headmaster's desk with raised table top and drawers. Birch

EXC5281

- dim.: 220 x 190,5 x 77 cm; 6 drawers, 4 open shelves; material: frame made of chipboard, 25 mm thick, in birch colour, drawer fronts made of chipboard, 18 mm thick, in birch colour, tabletop made of chipboard, 25 mm thick, in birch colour

Headmaster's desk with raised table top and drawers. Birch and white

EXC5283

- dim.: 220 x 190,5 x 77 cm; 6 drawers, 4 open shelves; material: frame made of chipboard, 25 mm thick, in birch colour, drawer fronts made of chipboard, 18 mm thick, in white colour, tabletop made of chipboard, 25 mm thick, in birch colour



Headmaster's desk with drawers. Birch

EXC5291

- dim.: 220 x 168 x 77 cm; 8 drawers, 4 open shelves; material: frame made of chipboard, 25 mm thick, in birch colour, drawer fronts made of chipboard, 18 mm thick, in birch colour, tabletop made of chipboard, 25 mm thick, in birch colour

Headmaster's desk with drawers. Birch and white

EXC5293

- dim.: 220 x 168 x 77 cm; 8 drawers, 4 open shelves; material: frame made of chipboard, 25 mm thick, in birch colour, drawer fronts made of chipboard, 18 mm thick, in white colour, tabletop made of chipboard, 25 mm thick, in birch colour

CONFERENCE TABLES AND COFFEE TABLES



Table top for the conference table. Birch

EXC8261

- dim.: 138 x 100 x 77 cm; material: tabletop made of chipboard, 25 mm thick, in birch colour, socles made of chipboard, 18 mm thick, in birch colour

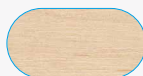

Table top for the coffee table. Birch

EXC8111

- dim.: 68 x 68 x 46,5 cm; material: tabletop made of chipboard, 25 mm thick, in birch colour, socles made of chipboard, 18 mm thick, in birch colour

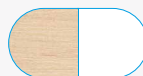

Table top for the coffee table. Birch and white

EXC8113

- dim.: 68 x 68 x 46,5 cm; material: tabletop made of chipboard, 25 mm thick, in birch colour, socles made of chipboard, 18 mm thick, in white colour



Table top for the conference table. Birch and white

EXC8263

- dim.: 138 x 100 x 77 cm; material: tabletop made of chipboard, 25 mm thick, in birch colour, socles made of chipboard, 18 mm thick, in white colour

WOODEN ERGO LEGS



SETS

- legs with a trapezoidal cross-section with rounded edges,
- material: solid beech wood

4 pcs.

NS0053 height 2 (51 cm)

NS0076 height 6 (76 cm)



ideal for Hexagonal Ergo Table in export catalogue 2020

6 pcs.

NS6076 height 6 (76 cm)

CHANGING UNIT



Double changing unit with compartments for plastic containers

NS3301

Functional double changing unit with sturdy frame. It provides space for everyday care and changing diapers. The changing unit has raised sides to ensure safety. The furniture's design offers storage space for plastic containers (sold separately) in which all the necessary accessories can be stored. In our store it's possible to find shallow containers (ex. NS2334) and deep containers

(ex. NS2330) in 4 colours with drawer slides. The high-density foam covered with phthalate-free and easy-to-clean PVC fabric provides comfort and softness. The mattress is available in two colours: white NS3302 and grey NS3303 (sold separately).

- dim. 103,7 x 71,8 x 107 cm;
- material: base made of chipboard,
- 18 mm thick, in birch colour
- storage space for 24 shallow containers or 12 deep containers made of plastic.
- the mattress and trays are sold separately



trays available on page 30

DOUBLE MATTRESS FOR CHANGING UNIT WITH COMPARTMENTS FOR PLASTIC CONTAINERS

Mattress designed for the double changing unit NS3301. The high-density foam covered with phthalate-free and easy-to-clean PVC fabric provides comfort and softness.

- dim.: 100 x 70 x 3 cm; material: PVC fabric in grey or white colour, polyurethane foam

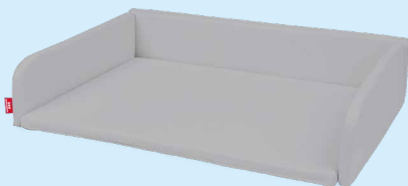

- Grey
NS3303

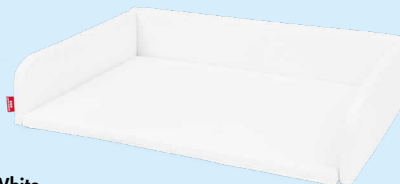









- White
NS3302

TABLES

CLASSIC STEEL TABLES

TRIANGULAR TOP

- 109 x 77 cm

white		NTH7200
red		NTH7201
blue		NTH7202
green		NTH7203
yellow		NTH7204
grey		NTH7205
mint		NTH7207
beech		NTH7208
birch		NTH7209

- tabletop dim.: 109 x 77 cm; triangle-shaped; it is made of laminated chipboard, 25 mm thick, in white, red, blue, green, yellow, grey, mint, beech, birch colour, with 2 mm thick PVC edge banding in multiplex colour











A rich selection of tabletops designed to fit into school interiors. The presented styles differ by shape, size and colouring. When combined with metal legs (sold separately) of different heights, they create a comfortable workspace adjusted to the age and height of the user. Thanks to the special connecting elements (NTH0001), the tabletops can be combined in

various configurations. This solution guarantees freedom and comfort of work for many users. Each tabletop is made of laminated chipboard, 25 mm thick, with multiplex edge banding. In our offer, we present tabletops in ten shapes and nine colours. The previously available colour palette of the banana tabletop has been enriched with a new shade - marine.



BIG RECTANGULAR TOP

- 180 x 80 cm

white		NTH7100
red		NTH7101
blue		NTH7102
green		NTH7103
yellow		NTH7104
grey		NTH7105
mint		NTH7107
beech		NTH7108
birch		NTH7109

- tabletop dim.: 180 x 80 cm; rectangular-shaped; it is made of laminated chipboard, 25 mm thick, in white, red, blue, green, yellow, grey, mint, beech, birch colour, with 2 mm thick PVC edge banding in multiplex colour



RECTANGULAR TOP

- 138 x 69 cm

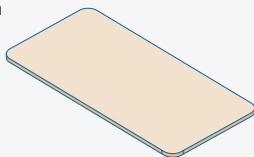

- tabletop dim.: 138 x 69 cm; rectangular-shaped; it is made of laminated chipboard, 25 mm thick, in white, red, blue, green, yellow, grey, mint, beech, birch colour, with 2 mm thick PVC edge banding in multiplex colour

white		NTH2000
red		NTH2001
blue		NTH2002
green		NTH2003
yellow		NTH2004
grey		NTH2005
mint		NTH2007
beech		NTH2008
birch		NTH2009

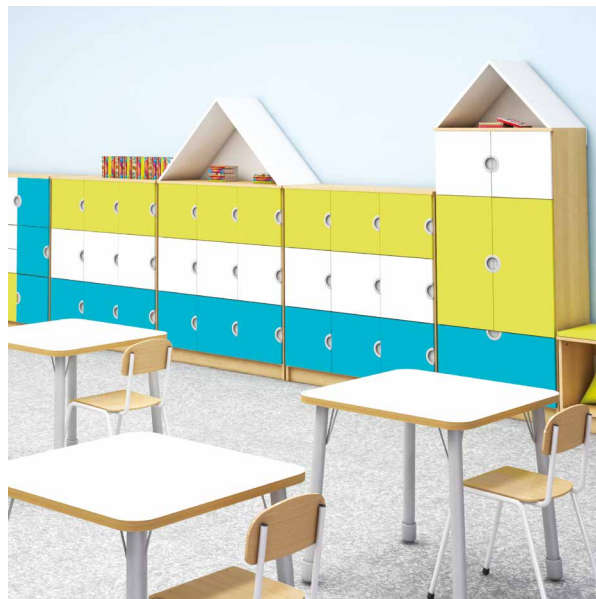

SQUARE TOP

- 69 x 69 cm

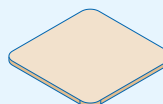

- tabletop dim.: 69 x 69 cm; square-shaped; it is made of laminated chipboard, 25 mm thick, in white, red, blue, green, yellow, grey, mint, beech, birch colour, with 2 mm thick PVC edge banding in multiplex colour

white		NTH4000
red		NTH4001
blue		NTH4002
green		NTH4003
yellow		NTH4004
grey		NTH4005
mint		NTH4007
beech		NTH4008
birch		NTH4009







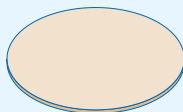



ROUND TOP

- ø 100 cm



- tabletop dim.: ø 100 cm; round-shaped; it is made of laminated chipboard, 25 mm thick, in white, red, blue, green, yellow, grey, mint, beech, birch colour, with 2 mm thick PVC edge banding in multiplex colour

white		NTH1000
red		NTH1001
blue		NTH1002
green		NTH1003
yellow		NTH1004
grey		NTH1005
mint		NTH1007
beech		NTH1008
birch		NTH1009







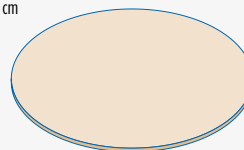



ROUND TOP

- ø 136 cm



- tabletop dim.: ø 136 cm; round-shaped; it is made of laminated chipboard, 25 mm thick, in white, red, blue, green, yellow, grey, mint, beech, birch colour, with 2 mm thick PVC edge banding in multiplex colour

white		NTH3000
red		NTH3001
blue		NTH3002
green		NTH3003
yellow		NTH3004
grey		NTH3005
mint		NTH3007
beech		NTH3008
birch		NTH3009



BANANA TOP

- 146,2 x 68 x 2,5 cm

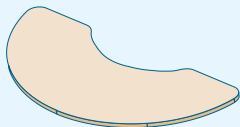

- tabletop dim.: 146,2 x 68 x 2,5 cm; it is made of laminated chipboard, 25 mm thick, in white, red, blue, green, yellow, grey, mint, beech, birch, marine colour; banana-shaped with rounded edges; edge banding made of PVC, 1 mm thick, in multiplex colour

white		NTH5000
red		NTH5001
blue		NTH5002
green		NTH5003
yellow		NTH5004
grey		NTH5005
mint		NTH5007
beech		NTH5008
birch		NTH5009
marine		NTH5010



SEMI CIRCLE TOP

- 135,2 x 68 cm

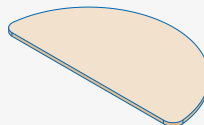

- tabletop dim.: 135,2 x 68 cm; semicircle-shaped; it is made of laminated chipboard, 25 mm thick, in white, red, blue, green, yellow, grey, mint, beech, birch colour, with 2 mm thick PVC edge banding in multiplex colour

white		NTH9000
red		NTH9001
blue		NTH9002
green		NTH9003
yellow		NTH9004
grey		NTH9005
mint		NTH9007
beech		NTH9008
birch		NTH9009



HEXAGONAL TOP

- 140 x 140 cm

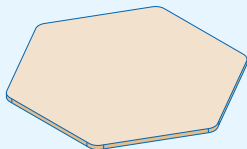

- tabletop dim.: 140 x 140 cm; hexagon-shaped; it is made of laminated chipboard, 25 mm thick, in white, red, blue, green, yellow, grey, mint, beech, birch colour, with 2 mm thick PVC edge banding in multiplex colour

white		NTH6000
red		NTH6001
blue		NTH6002
green		NTH6003
yellow		NTH6004
grey		NTH6005
mint		NTH6007
beech		NTH6008
birch		NTH6009



OCTAGONAL TOP

- 146 x 146 cm

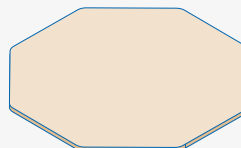

- tabletop dim.: 146 x 146 cm; octagon-shaped; it is made of laminated chipboard, 25 mm thick, in white, red, blue, green, yellow, grey, mint, beech, birch colour, with 2 mm thick PVC edge banding in multiplex colour

white		NTH8000
red		NTH8001
blue		NTH8002
green		NTH8003
yellow		NTH8004
grey		NTH8005
mint		NTH8007
beech		NTH8008
birch		NTH8009





CONNECTORS FOR TABLES

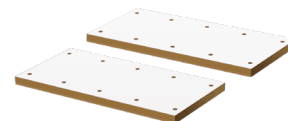
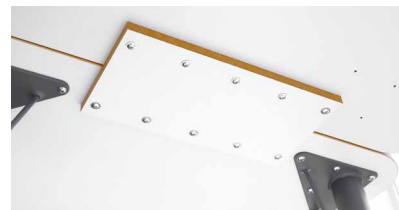

Connecting elements for conference tables

NTH001

Special connecting elements for joining tabletops together. They allow you to create many different table configurations in order to provide more working space. The connecting elements should be attached to the underside of the tabletops to ensure stability and to prevent the tables from sliding apart.

- 2 pcs.; dim.: 28 x 14,2 cm; table fittings; material: MDF board, 12 mm thick, in white colour

CREATE YOUR OWN CONFIGURATION

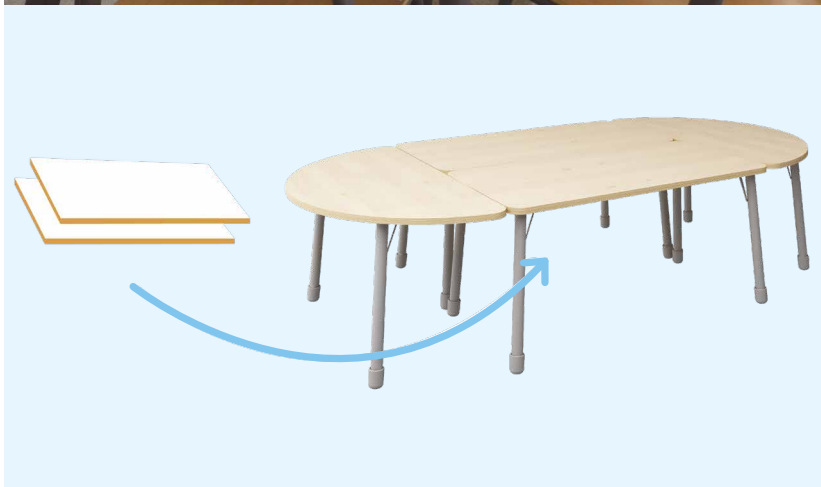
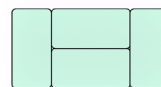
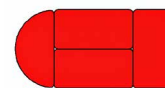
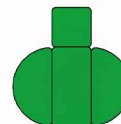
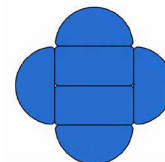
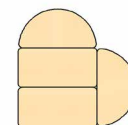



METAL LEGS

A collection of metal legs with a diameter of 45 mm. Available range of height regulations: 1-3 and 3-6 or 5 heights. Their durable steel construction and connecting elements guarantee firmness and comfort of use. Angled legs (5 degrees) provide extra stability. The legs were additionally equipped with non-slip furniture pads made of plastic to protect the floor. This set of table legs combined with our selection of tabletops allows you to create functional school interiors. The given dimensions reflect the height of the table after the installation of legs.

IN SEVERAL HEIGHTS

- 4 pcs; material: metal



WITH ADJUSTMENT



SLIM



Slim Tables available in export catalogue 2021

Ergonomic and comfortable Slim table holder. Thanks to this solution, you can quickly and efficiently move the Slim tables from place to place as well as safely store them while saving space. The mounted wheels allow mobility, and the possibility of locking them, ensures safety.

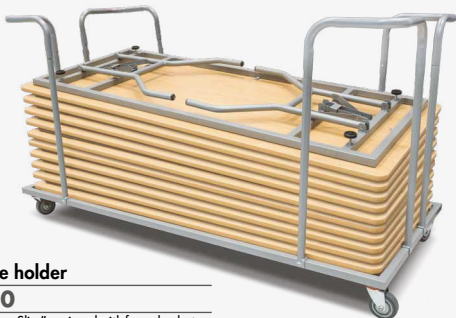

**Slim table holder
NS7650**

- table holder „Slim“ equipped with four wheels, two of them with breaks; material: metal; colour: grey; it can store up to 10 tables; dim.: 83 x 187 x 86 cm



BUTTERFLY

SQUARE



other table's shape available in export catalogue 2020

Comfortable tables for children distinguished by their practical form and elegant shape. Solid tabletop with rounded edges guarantees safety during playtime. Ours tabletops are made of plastic reinforced with a metal frame and metal legs with regulated height: 40-60 cm (height 0-3).

Non-slip plastic furniture pads protect the floor from scratches. Butterfly chairs, available in matching shapes and sizes, are a perfect addition to these tables.

- dim.: 62 x 62 cm; available colours: red, blue, green, yellow, grey



red		YC9011
blue		YC9012
green		YC9013
yellow		YC9014
grey		YC9015



DESKS

MOVABLE



**Single school bench
with tilted tabletop
and height regulation 3-6
NS2749**

Single desk with the possibility of tilting the tabletop in the range from 0 to 45 degrees.

- dim.: 70 x 50 cm;
- tabletop's height regulation: 59-76 cm
- table top made of 18 mm laminated MDF in beech colour
- metal frame and legs, powder coated grey

WORKBENCHES

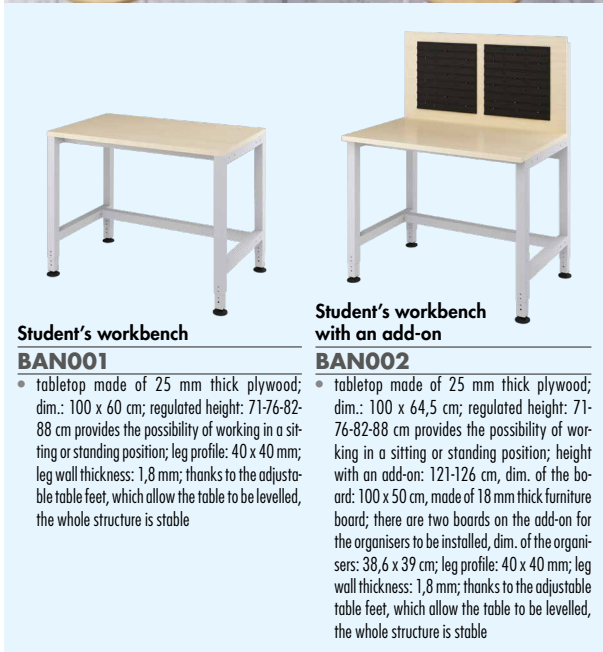

**Student's workbench
BAN001**

- tabletop made of 25 mm thick plywood; dim.: 100 x 60 cm; regulated height: 71-76-82-88 cm provides the possibility of working in a sitting or standing position; leg profile: 40 x 40 mm; leg wall thickness: 1,8 mm; thanks to the adjustable table feet, which allow the table to be levelled, the whole structure is stable

**Student's workbench
with an add-on
BAN002**

- tabletop made of 25 mm thick plywood; dim.: 100 x 64,5 cm; regulated height: 71-76-82-88 cm provides the possibility of working in a sitting or standing position; height with an add-on: 121-126 cm, dim. of the board: 100 x 50 cm, made of 18 mm thick furniture board; there are two boards on the add-on for the organisers to be installed, dim. of the organisers: 38,6 x 39 cm; leg profile: 40 x 40 mm; leg wall thickness: 1,8 mm; thanks to the adjustable table feet, which allow the table to be levelled, the whole structure is stable

Tables perfect for every studio or workshop. The tabletops are made of a thick, durable plywood which ensures stability and sturdiness of the construction. Thanks to the regulated height of the legs, you can work standing or sitting. These tables are universal, and they will prove useful during many workshop activities.



**Teacher's workbench
BAN003**

- tabletop made of 25 mm thick plywood; dim.: 150 x 60 cm; regulated height: 71-76-82-88 cm provides the possibility of working in a sitting or standing position; leg profile: 40 x 40 mm; leg wall thickness: 1,8 mm; thanks to the adjustable table feet, which allow the table to be levelled, the whole structure is stable

**Teacher's workbench
with an add-on
BAN004**

- tabletop made of 25 mm thick plywood; dim.: 150 x 64,5 cm; regulated height: 71-76-82-88 cm provides the possibility of working in a sitting or standing position; height with an add-on: 121-126 cm, dim. of the board: 100 x 50 cm, made of 18 mm thick furniture board; there are four boards on the add-on for the organisers to be installed; two boards with the dim.: 38,6 x 39 cm and two boards with the dim.: 38,6 x 13 cm; leg profile: 40 x 40 mm; leg wall thickness: 1,8 mm; thanks to the adjustable table feet, which allow the table to be levelled, the whole structure is stable



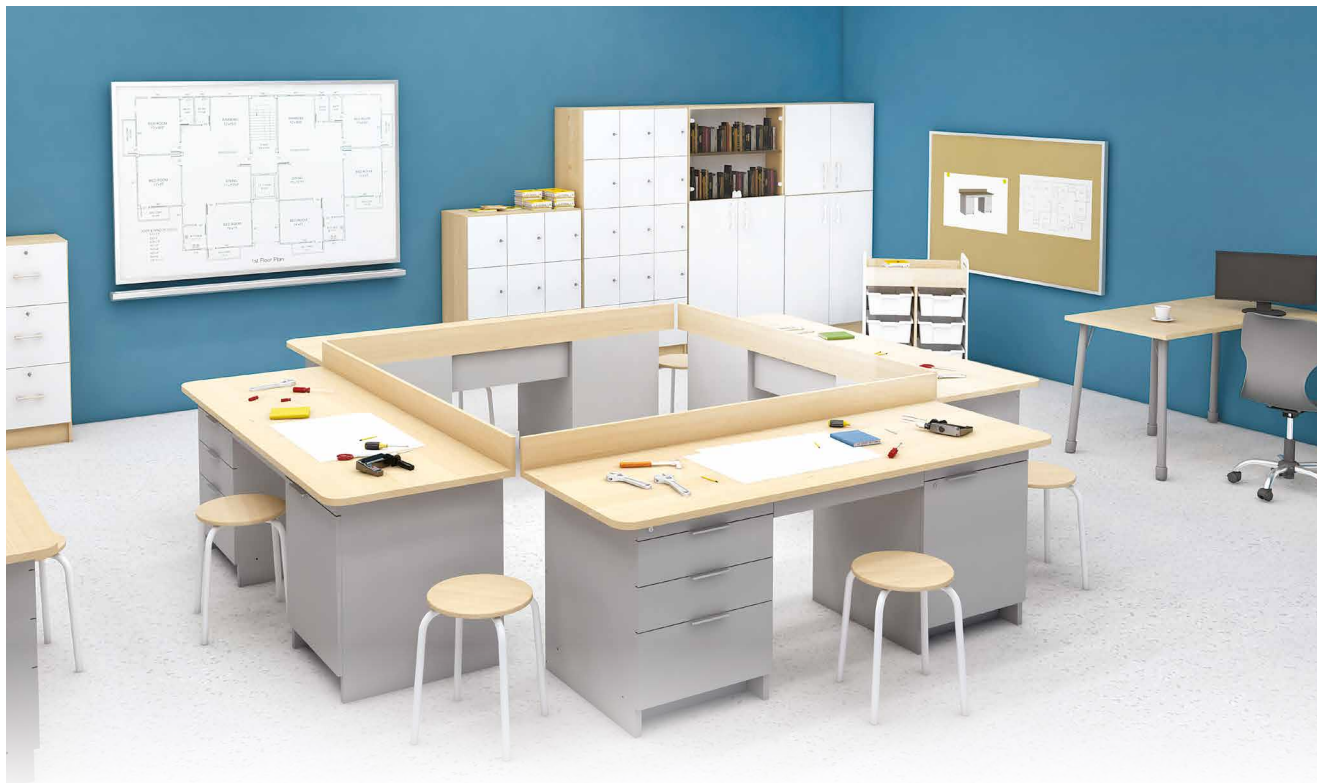

Workbench

ARN001

- dim. 200 x 63,3 x 75,5 cm; school workbench made of 18 mm and 25 mm thick furniture board in grey colour; tabletop is made of plywood, 18 mm thick, back plinth of the tabletop is made of plywood, 18 mm thick and 12 mm high; the workbench is equipped with: doors closed with a lock, 1 pc, aluminium handles, drawers, 4 pcs: 3 drawers with central locking are placed on the left side; 1 shelf without a lock is placed in the central part under the tabletop



CHAIRS

WOODEN

MIMI GREY

Ergonomic and stackable chair with grey back and contoured seat. The chair's frame resembles natural wood. It has rounded corners and edges. Legs are additionally equipped with plastic chair glides.

- 1 pc.; material: varnished beech plywood, colour: grey and wood



more colours of Mimi chairs available in export catalogue 2020



0

NS9040

- seat height: 21 cm

1

NS9041

- seat height: 26 cm

2

NS9042

- seat height: 30 cm

3

NS9043

- seat height: 34 cm



STOOL



more stools available in export catalogue 2020



Sitting stool on metal legs. 6

ATN600

- size 6 is designed for users over the age of 13 with a height of 159-188 cm; stackable; height to the top surface of the seat is 46 cm; one piece seat and back in birch colour made of plywood covered with HPL; the frame is made of metal in white colour with a circular cross section and diameter of 26 mm; equipped with chair plugs

CLOAKROOMS



METAL

Metal wardrobes and add-ons, which when combined, create a functional cloakroom. The colourful doors make the space more welcoming for children and teenagers. The solid construction of the wardrobes and the material from which they were made, guarantee their durability.

Solid metal unit, which will prove useful especially in workshops or studios, for storing heavy items. The simple construction helps to maximise the usable space of the furniture.



Metal unit with reinforced shelves
NG9080

- durable metal unit, dim.: 90 x 50 x 180 cm
- maximum load on one shelf: 60 kg

LOW 4-PERSON METAL CLOAKROOM

- dim.: 152 x 48 x 135 cm,
- dim. of the container: 37 x 40 x 128 cm,
- dim. of the doors: 38 x 129 cm
- the body of the wardrobe is grey, doors are grey, blue, yellow and green



- grey
NG4204



- blue
NG4214



- yellow
NG4224



- green
NG4234

ADD-ON FOR LOW 4-PERSON METAL CLOAKROOM

- dim.: 380 x 48 x 135 cm,
- dim. of the container: 37 x 40 x 128 cm,
- dim. of the doors: 37,8 x 129,3 cm
- the body of the wardrobe is grey, doors are yellow



- grey
NG4201



- blue
NG4211



- yellow
NG4221



- green
NG4231

TALL 4-PERSON METAL CLOAKROOM WITH DOORS

- dim. of the frame: 76 x 48 x 185 cm;
- 4 containers, dim.: 33 x 48 x 84,6 cm;
- 4 doors, dim.: 33 x 85; grey frame,
- doors in grey, blue, yellow and green colour; 2 keys;
- material: metal



- grey
NG4404



- blue
NG4414



- yellow
NG4424



- green
NG4434

9-PERSON METAL CLOAKROOM

- dim.: 114 x 48 x 135 cm;
- dim. of the container: 37,5 x 44 x 40 cm;
- dim. of the doors: 32,7 x 37,8 cm;
- the body of the wardrobe is grey, doors are grey, yellow, blue and green



- grey
NG9909



- blue
NG9919



- yellow
NG9929



- green
NG9939

3-PERSON ADD-ON FOR 9-PERSON METAL CLOAKROOM

- dim.: 38 x 48 x 135 cm;
- dim. of the container: 38 x 45 x 38 cm;
- dim. of the doors: 32,7 x 37,8 cm;
- the body of the wardrobe is grey, doors are grey, yellow, blue and green



- grey
NG9303



- blue
NG9313



- yellow
NG9323



- green
NG9333

TALL 8-PERSON METAL CLOAKROOM

- dim.: 76 x 48 x 175 cm;
- dim. of the container: 33 x 45 x 38,1 cm;
- dim. of the doors: 32,7 x 37,8 cm;
- the body of the wardrobe is grey, doors are grey, blue, yellow and green



- grey
NG8808



- blue
NG8818



- yellow
NG8828



- green
NG8838

CARPETS

Carpets make the interiors cosy and comfortable. The presented carpets, which complete the Fantasy collection, in addition to aesthetic values, also provide space for physical and mental activities. Themed prints can inspire lots of fun games as well as stimulate curiosity and encourage interaction. The material from which they were made ensures the durability of the product.

POLYAMIDE



Numbers. Round carpet MU0006

Round polyamide carpet covered with latex on the underside. The print of numbers on colourful backgrounds proves useful in learning to count or during games.

- diam.: 2 m

HEAT SET FRISE

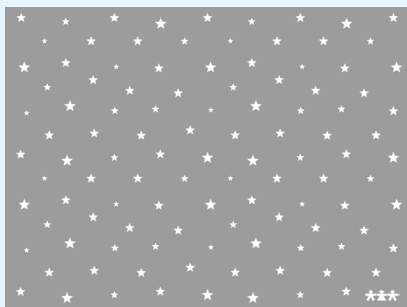

Grey stars carpet DL0501

- grey carpet with white-coloured stars; heat set frise yarn; dim.: 3 x 4 m

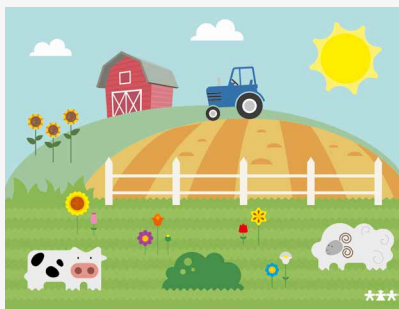

Farm. Fantasy polyamide carpet MU0002

Big carpet "Farm" perfect for nurseries and kindergartens. This product will complement any interior as well as create space for relaxation or playtime. The fabric is resistant to abrasion. It also has anti-microbial and anti-mould properties. The carpet is easy to clean.

- colours do not fade; fabric: polyamide yarn; dim.: 4 x 3 m

Wave. Fantasy polyamide carpet MU0003

Big carpet "Wave" perfect for nurseries and kindergartens. This product will complement any interior as well as create space for relaxation or playtime. The fabric is resistant to abrasion. It also has anti-microbial and anti-mould properties. The carpet is easy to clean.

- colours do not fade; fabric: polyamide yarn; dim.: 4 x 3 m



Royal. Fantasy polyamide carpet MU0004

Big carpet "Royal" perfect for nurseries and kindergartens. This product will complement any interior as well as create space for relaxation or playtime. The fabric is resistant to abrasion. It also has anti-microbial and anti-mould properties. The carpet is easy to clean.

- colours do not fade; fabric: polyamide yarn; dim.: 4 x 3 m

Forest. Fantasy polyamide carpet MU0005

Big carpet "Forest" perfect for nurseries and kindergartens. This product will complement any interior as well as create space for relaxation or playtime. The fabric is resistant to abrasion. It also has anti-microbial and anti-mould properties. The carpet is easy to clean.

- colours do not fade; fabric: polyamide yarn; dim.: 4 x 3 m



SCHOOL BOARDS

A board is an indispensable part of every classroom. It is a symbol of school and education, and because of it, the quality really matters. In our offer, you can find different variants of the classic board.



Green board. Single
YC8000

- single green board, dim.: 100 x 170 cm

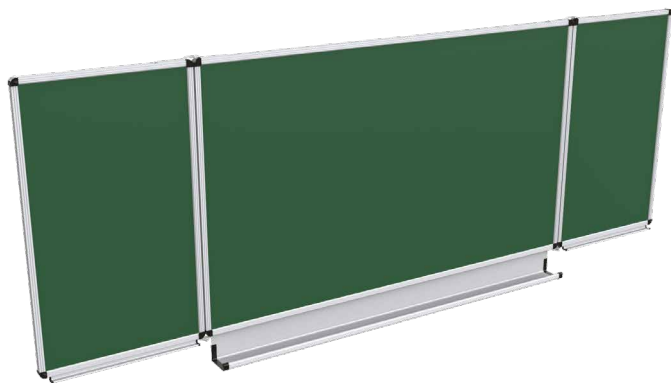

Green board. Triptych
YC8001

- triptych board in green colour; dim.: 100 x 340 cm

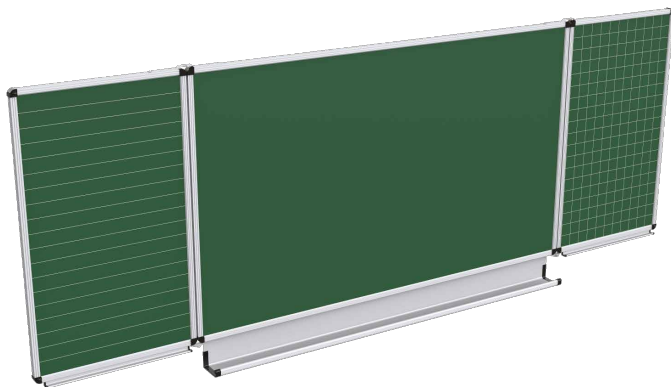

Green board with lines and squares
YC8002

- triptych board in green colour; movable parts with two patterns: grid and lines, dim.: 100 x 340 cm

DINING ROOM

HIGH CHAIRS



Modern feeding chair

BT0018

This chair is perfect for everyday meals. It's cosy and easy to use design has a positive effect on the comfort of a young user. Additionally, the chair is equipped with a 5-point harness, removable seat cover, regulated tabletop (distance), and a removable tray. The durability and stability of the chair is ensured by non-slip legs positioned at an optimal angle.

- dim.: 62 x 77 x 92 cm; material: polypropylene, steel; colour of the cover: beige; age: 1+



MELAMINE DISHES



NO SPILL SIPPY CUP



more melamine dishes
available in export
catalogue 2020

Practical no-spill sippy cup which helps the child to learn independent drinking. It is equipped with a mouthpiece to prevent liquid from spilling and two easy grip handles to ensure comfort. The cup consists of two elements: a liquid container and

a lid with a mouthpiece to facilitate the cleaning process.

- dim. of the cup: height: 6,5 cm, diam. 7 cm; capacity: 200ml; material: plastic; colour: transparent lid, age: 3+



- green
NS9119

- yellow
NS9139

- blue
NS9109

- orange
NS9129

CUTLERY

A cutlery kit for toddlers with an engraving of a lamb and the Nowa Szkola logo. The shapes and sizes of the tools are suitable for little hands. This kit is a perfect addition to the nursery dining rooms.

- 1 pc.; lgth. 12,5 cm; material: stainless steel



Toddler spoon
NS9157

Toddler knife
NS9158

Toddler fork
NS9159



Waterproof bib. Pastel
BT0019

Pastel bib made of soft, light fabric. It effectively protects the child's clothes from getting dirty. Regulated fastener facilitates the process of putting the bib on and off. It is additionally equipped with a big pocket which can collect pieces of food. The bib is also easy to clean and doesn't take a lot of space when folded. Thanks to these features, it can be used during trips or when travelling.

- dim.: 27,5 x 22,5 cm; material: synthetic fabric; age: 1+



BATHROOM



Toilet seat cover

BT0016

Practical seat cover which is light and easy to clean. It facilitates the process of learning how to use the toilet. When folded, it doesn't take up a lot of space and can be carried in a bag or a backpack.

- 1 pc.; dim. 35 x 26 cm; weight: 0,5 kg; colour: blue; material: polypropylene; age: 3+



Non slip white stool

BT0017

Practical stool which helps children to be more independent during their everyday routine. It allows them to use the toilet, wash hands or reach their favourite toy. The stability of the stool is ensured by non-slip elements on the bottom of the product and on its surface. It is made of plastic and because of that it can be carried by a child.

- dim. 36,5 x 25 x 13 cm; material: polypropylene, thermoplastic rubber; colour of the stool: white; colour of the dots is sent at random; age: 3+

SAFETY



Safety lock. Transparent

BT0020

Two-element safety lock which can be easily assembled without any tools. It protects children from trapping their fingers in doors or accessing dangerous objects. The lock is equipped with strong double-sided adhesive tape.

- 1 pc., dim.: 9,6 x 1,3 x 4 cm, weight: 0,05 kg; material: PC; colour: transparent; age: 1+



ACTIVITY PLAY



SOFT PLAY

SEATING AREA

BLACK & WHITE PILLOWS

Contrast cushions stimulate and engage the sense of touch and sight of the little ones in a comfortable in a nice way. The soft fabric combined with eye-catching prints boost creativity in children and encourage them to interact with it.



Contrast cushion

NS3400

Big cushion designed to stimulate child's senses and motor development. Many of its functions are important for proper development of a child. Black and white eye-friendlily patterns attract attention and train the ability to con-

centrate. It's perfect to learn how to lie on the tummy, sit down, play and relax. Thanks to the use of high quality soft Minky fleece with embossed dots, the cushion is warm and comfortable. Embossed dots also stimulate the sense of touch. Raised sides of the cushion allow the baby's head to be supported. The product's additional asset is the possibility to remove the arch from the mattress. The cushion is filled with pieces of cut foam which ensure the comfort of use. The set consists of 4 contrast cushions.

- dim. of the cushion: outer diam.: 136 cm, inner diam.: 96 cm, height 20 cm; cover made of Minky fabric in black and white; dim. of the cushions: flower 50 x 9 x 50 cm, circle 48 x 9 x 48 cm, star 53,4 x 9 x 51 cm, water drop 48 x 9 x 57,9 cm; covers of the cushions are made of cotton fabric with printed black and white patterns: black dots, white stars, checker, filling: pieces of cut foam



Star. Contrast cushion
NS3401

• dim.: 35 x 35 cm

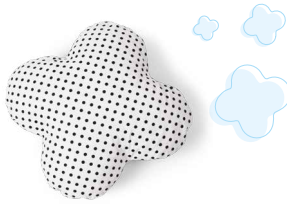

Flower. Contrast cushion
NS3402

• dim.: 35 x 35 cm

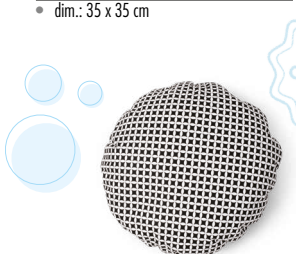

Circle. Contrast cushion
NS3403

• dim.: 35 x 35 cm

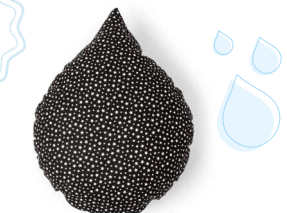

Water drop. Contrast cushion
NS3404

• dim.: 35 x 35 cm



Square. Contrast cushion
NS3405

• dim.: 30 x 30 cm



FLAT CUSHION



more flat cushions available
in export catalogue 2020
and export catalogue 2021



**Flat foam cushions
with a squeaker in a bag**
NS1894

• dim.: 32 x 32 x 3 cm, with the non-slip PVC cover in yellow, orange, green, marmara blue, white, grey colours; filled with polyurethane foam; the set consists of 6 pieces; weight: 2,5 kg; foam cushions made of foam covered with phthalate-free PVC fabric; each disc is equipped with a squeaker; the trimming is made of reinforced cotton tape ribbon; storage: a bag made of oxford fabric in light blue colour; closed with a string with a plastic stopper





Nature.
Sitting foam cushions in a bag
NS2237

- dim.: 32 x 32 x 2 cm, with the non-slip PVC cover in white and grey colour; filled with polyurethane foam; the set consists of 10 pieces with prints; weight: 1,3 kg; inspired by nature sitting discs made of foam covered with phthalate-free PVC fabric; the trimming is made of reinforced cotton tape ribbon; storage: a bag made of oxford fabric in cornflower colour; closed with a string with a plastic stopper



more flat cushions available
 in export catalogue 2020
 and export catalogue 2021

SOFT PILLOWS

A pillow with soft filling, covered with a nice to touch sensory fabric. Perfect addition to sensory integration rooms and any calming or therapeutic spaces. Vivid colours stimulate children's curiosity and engage the sense of sight while intriguing textures engage the sense of touch and perception.

- dim.: 30 x 30 cm



grey		NS3280
turquoise		NS3281
mint		NS3282
yellow		NS3283
fuchsia		NS3284
heather		NS3285
ecru		NS3286
orange		NS3287
navy		NS3288

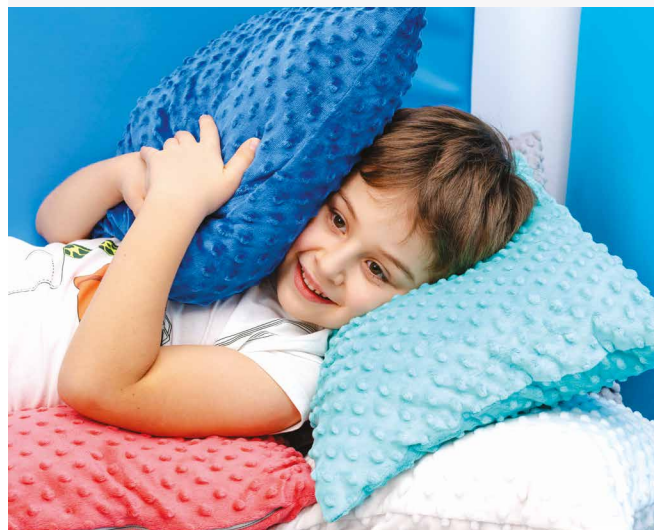

FOLDABLE SOFAS

Functional seat, which when unfolded turns into a comfortable chaise longue. When folded, it doesn't take up too much space, and if needed, it can create a calm and relaxing space to rest after vigorous games or after a walk. It is perfect for toddlers' corners, reading rooms or common rooms. The seat is made of a high quality, durable PVC fabric, which is easy to clean and disinfect. The inside of the seat is filled with a polyurethane foam with increased density to ensure the comfort of use, while the non-slip surface guarantees safety. Sold in many colours.

MEDIUM

- dim.: 60 x 119 x 52 cm
- dim. when folded 60 x 79 x 33 cm

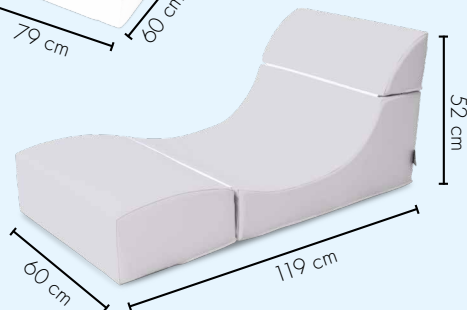
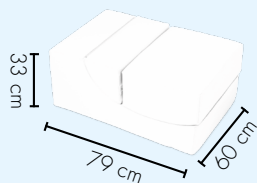

grey		NS4172
white		NS4173
lime		NS4174
blue		NS4175
yellow		NS4176
rose		NS4177
marine		NS4178



BIG

- dim.: 70 x 150 x 62 cm
- dim. when folded 70 x 100 x 39 cm

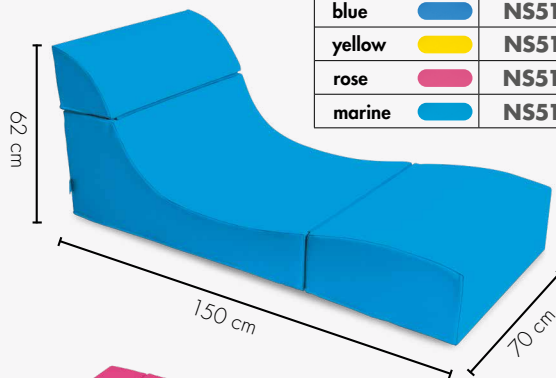

grey		NS5172
white		NS5173
lime		NS5174
blue		NS5175
yellow		NS5176
rose		NS5177
marine		NS5178

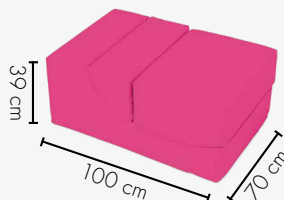

small size available
in export catalogue 2021





CUSHION PEAR

Successful rehabilitation requires good quality functional equipment. Foam shapes are standard tools necessary for the implementation of therapy. We offer them in many different shapes and sizes. Their inside is made of polyurethane foam, covered with an aesthetic phthalate-free PVC fabric in var-

ious colours. Thanks to foam shapes, the users can effectively train the upper and lower parts of their bodies. Pear-shaped cushions are great for sitting and exercising. They adapt perfectly to the position of the body, and they can be formed according to the needs of the user. Additionally, they can prove

useful during rehabilitation and other therapeutic activities. However, they are also perfect as a comfortable seat. Some models are equipped with a handle which makes moving them from one place to another much easier. Their quality design, high quality granules and durable PVC or Oxford

fabric guarantee long service life. Styrofoam granules, which can be found inside pear-shaped cushions and other rehabilitation cushions, wear out naturally after about a year of intensive use. We recommend refilling the cushions with new granules which you can find under the code: NS1585.



OXFORD

- dim.: 90 x 120 cm;
- weight: 7,5 kg



Big pear-shaped rehabilitation cushion - green black grey

NS3310

- styrofoam granules; colour: green-black-grey

Big pear-shaped rehabilitation cushion - blue black navy

NS3311

- styrofoam granules; colour: blue - black -navy

PVC

- dim.: 90 x 120 cm;
- weight: 7,5 kg



Big pear-shaped rehabilitation cushion - grey with a handle

NS3320

- styrofoam granules; colour: two shades of grey

Big pear-shaped rehabilitation cushion - beige and grey with a handle

NS3321

- styrofoam granules; colour: beige - grey



ROCKERS



Giraffe rocker

NS3413

- dim.: 80 x 24 x 79,5 cm;
- the cover is made of PVC fabric in brown colour; it is filled with polyurethane foam; weight: 3 kg; two-sided print in the form of a giraffe



more rockers available
in export catalogue 2020
and export catalogue 2021

Rocker in the shape of an adorable pet provides lots of fun and at the same time stimulates the vestibular system, promoting healthy child development. The stable structure and wide base of the rocker ensure safety during use. The high density of polyurethane foam guarantees the durability of the product. The cover is made of phthalate-free PVC fabric which is easy to clean and disinfect. Some models are equipped with a handle which makes moving them from one place to another much easier.



Zebra rocker

NS3414

- dim.: 84,5 x 24 x 61 cm;
- the cover is made of PVC fabric in charcoal grey colour; it is filled with polyurethane foam; weight: 2,2 kg; two-sided print in the form of a zebra





Husky rocker
NS3410

- dim.: 24 x 78 x 59 cm; material: phthalate-free PVC fabric in grey colour, dog silhouette print; filling: polyurethane foam



Whale rocker
NS3411

- dim.: 96,6 x 24 x 46 cm; equipped with a handle, material: phthalate-free PVC fabric in blue – white – black colour; filling: polyurethane foam



Swan rocker
NS3412

- dim.: 75 x 24 x 68,8 cm, material: phthalate-free PVC fabric in white – orange – black colour; filling: polyurethane foam

TODDLER'S TRACKS



Foam shapes designed especially for toddlers who want to engage in more active playtime. With the foam shapes, it is possible to create safe and varied obstacle courses. They provide space for playtime or rehabilitation exercises for children in need of special care, or additional sensory stimulation. In our offer, you can find 9 module proposals that can be purchased in a set. All foam shapes are made of phthalate-free PVC fabric which is easy to clean. They are filled with polyurethane foam with increased density. It ensures comfort and durability. The non-slip bottom of the foam elements guarantees safety during exercise and play.

Rehab tracks for toddlers. Set NS3419

- the set contains 4 elements
- polyurethane foam

<p>Wedge</p> <ul style="list-style-type: none"> • dim.: 60 x 39 x 20 cm 	<p>Wave ramp</p> <ul style="list-style-type: none"> • dim.: 60 x 39 x 20 cm
<p>Wave</p> <ul style="list-style-type: none"> • dim.: 60 x 39 x 5 cm 	<p>Flower</p> <ul style="list-style-type: none"> • dim.: 60 x 39 x 14 cm



Rehab tracks for toddlers. Set maxi

NS3420

- the set contains 9 elements;
- polyurethane foam; grey non-slip fabric; material: PVC fabric

<p>Wedge</p> <ul style="list-style-type: none"> • dim.: 60 x 39 x 20 cm 	<p>Wave ramp</p> <ul style="list-style-type: none"> • dim.: 60 x 39 x 20 cm 	<p>Wave</p> <ul style="list-style-type: none"> • dim.: 60 x 39 x 5 cm
<p>Flower</p> <ul style="list-style-type: none"> • dim.: 60 x 39 x 14 cm 	<p>Hillock</p> <ul style="list-style-type: none"> • dim.: 60 x 39 x 10 cm 	<p>Houses</p> <ul style="list-style-type: none"> • dim.: 60 x 39 x 12 cm
<p>Hill</p> <ul style="list-style-type: none"> • dim.: 60 x 39 x 10 cm 	<p>Mattress</p> <ul style="list-style-type: none"> • dim.: 60 x 39 x 5 cm 	<p>Half wave</p> <ul style="list-style-type: none"> • dim.: 60 x 39 x 9,5 cm

BALL POOLS



new colours of the pools
and new colours of plastic balls

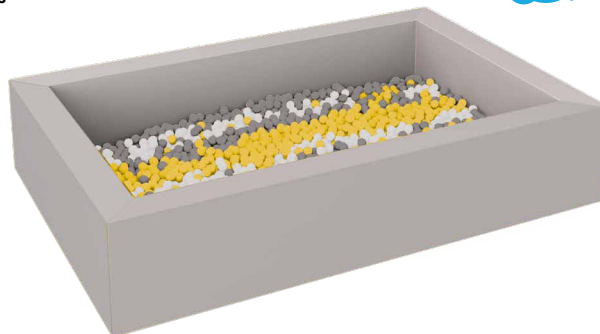

$$\begin{array}{c}
 \text{grey} + \text{yellow} + \text{white} = \\
 2\,000 + 1\,500 + 1\,500 = \\
 \text{grey} \quad \text{yellow} \quad \text{white}
 \end{array}$$



5 000 plastic balls

Softplay ball pools.

Rectangle 3 x 2 m

NS2002

- 300 x 200 60 cm
- inside area 4.16 m²
- 5000 plastic balls ø 6.5 cm
- the cover is made of the Oxford fabric



$$\begin{array}{c}
 \text{grey} + \text{white} + \text{turquoise} = \\
 1\,500 + 1\,500 + 1\,000 = \\
 \text{grey} \quad \text{white} \quad \text{turquoise}
 \end{array}$$



4 000 plastic balls

Softplay ball pools.

Square 1.5 x 1.5 m

NS2001

- 150 x 150 x 60 cm
- inside area 1.21 m²
- 4000 plastic balls, ø 6 cm
- the cover is made of the Oxford fabric



$$\begin{array}{c}
 \text{grey} + \text{turquoise} = \\
 500 + 500 = \\
 \text{grey} \quad \text{turquoise}
 \end{array}$$



1 000 plastic balls

Softplay ball pools.

Round

NS2100

- wall thickness 15 cm
- ø 150 x 40 cm
- 1000 plastic balls, ø 6.5 cm
- the cover is made of non-slip PVC fabric





Softplay ball pools. Square 2 x 2 m

NS2000

- 200 x 200 x 60 cm
- inside area 2.6 m²
- 4000 plastic balls, ø 6 cm
- the cover is made of the Oxford fabric



4 000 plastic balls

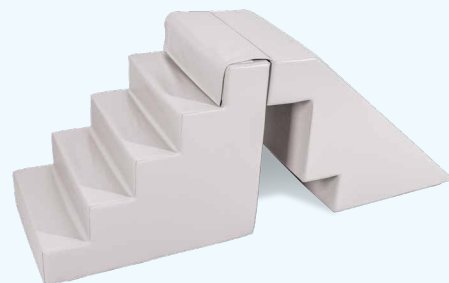

Stairs with a slide for softplay ball pools

NS1290

- dim.: 60 x 200 x 80 cm; material: polyurethane foam covered with non-slip PVC fabric in dove grey and grey colour; intended use: ball pools square and rectangle where it can serve as the stairs and the slide; two elements, the stairs, dim.: 89 x 69 x 80 cm and the slide, 110 x 60 x 80 cm; the two are connected with Velcro; the stairs have got 5 steps





SOFTPLAY POOL BALLS

Set of balls which can be used to fill a dry pool or a playpen. Their resilience, size and variety of colours provide psychomotor stimulation and posi-

tively influence sensory development in children.

- 500 pcs.; diam. of the ball: 6,5 cm;
- material: plastic

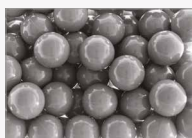

Grey
NS9800



White
NS9801



Turquoise
NS9803

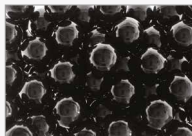

Black
NS9802



Fuchsia
NS9804



Yellow
NS9805

MANY COMBINATIONS

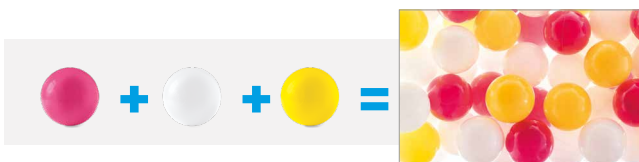
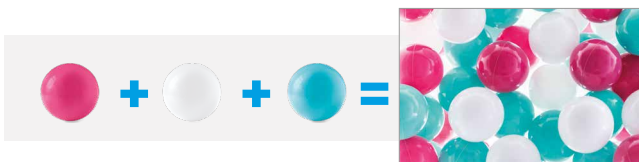
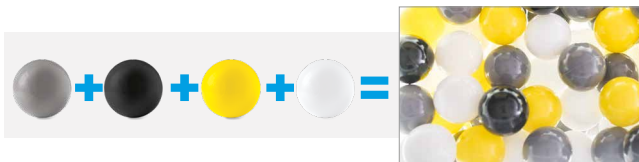

transparent and colourful
balls available
in export catalogue 2020

SPECIAL EDUCATION NEEDS

THERAPY

Solid and thought through therapeutic aids are indispensable in rooms intended to meet special educational needs. They were designed with the unique needs of students in mind, in order to provide the best solutions for them. The used materials ensure durability and the comfort of use.

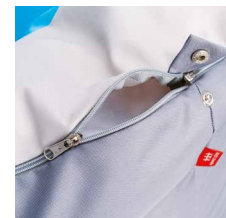
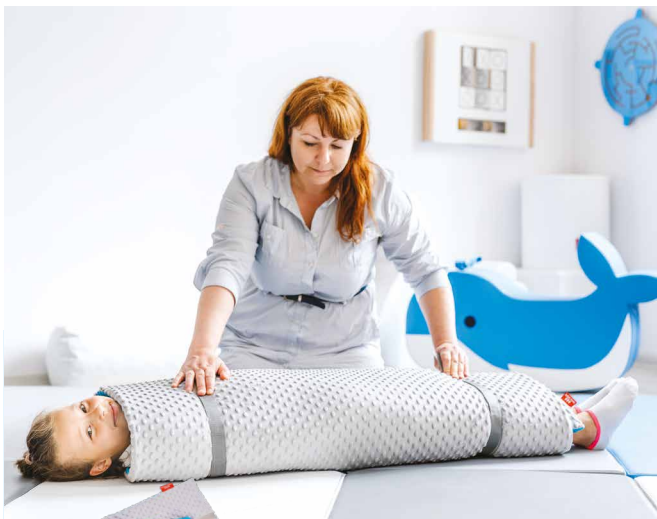

Sensory tunnel NS8993

Sensory tunnel is an indispensable aid during the sensory integration therapy. It is especially recommended for children with autism spectrum disorder, cerebral palsy syndrome or Down syndrome. This product was designed to give children the possibility to feel tactile stimuli and it provides deep pressure stimulation when going through, rolling or lying in the tunnel. The tunnel can also serve as a hiding place where a child can hide and calm down their

emotions or just relax. The product's construction provides additional tactile stimulation. The specialist or the parent can roll, put pressure or massage the person inside the tunnel. This aid is entirely made of durable Oxford fabric and its walls are filled with cut pieces of polyurethane foam, which due to resilience retain their properties for longer than the commonly used polystyrene granules.

- dim.: lgth.: 100 cm, inner diam.: 50 cm, outer diam.: 80 cm; material: Oxford fabric in marine colour and two shades of grey; filling: cut pieces of polyurethane foam



Pancake. Therapy carpet NS8995

Therapy aid designed especially for sensory therapy. The child should be carefully rolled into a pancake – carpet so as to ensure adequate pressure and stimulation of the receptors. The specialist or the parent can additionally massage, press or compress the child inside the pancake. The product is equipped with Velcro straps which allow the child to easily get out of the pancake. Thanks to this kind of therapy the child can observe an increase in awareness of their own body as

it stimulates the vestibular, proprioceptive and tactile systems. The product is recommended not only for children with sensory processing disorder, but also for those who love cosy tight spaces. The soft pancake is made of nice to touch Minky fabric and it is filled with polyurethane foam. Its characteristic round embossing on the surface and its dimensions allow to use it as a therapeutic carpet during theme or floor games.

- dim.: lgth.: 100 cm, width: 118 cm; material: Minky fabric in turquoise and grey colour; filling: foam 1,5 cm thick



CAGE SOLD WITHOUT SWINGS AND MATTRESSES



Small SI cage
NS3109

Small SI cage perfect for sensory integration exercises. The system can be upgraded by the addition of hanging elements. It is equipped with many items which promote the development of motor skills. Inside, you can find a two-sided climbing wall. On one side of the wall, there are stone hand holds, and on the other, there are wooden notches. The SI cage also has got a board with holes for climbing as well as ladders on the ceiling. Holes were placed in the ceiling structure to facilitate the process of mounting the brackets.

- plywood natural
- dim.: 200 x 200 x 216 cm



Sensory suspension frame
NS3110

Ceiling suspension frame. It must be fixed to a wall made of hollow brick,

brick or reinforced concrete. The frame cannot be mounted on plasterboard.

- regulation: from 3 to 4,4 m; material: powder coated steel in white colour



- hollow brick wall
- brick wall
- reinforced concrete



mattresses and pillows available in export catalogue 2021

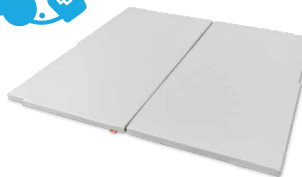

Mattress for the small SI cage
NS2219

- it's made of durable, easy to clean and disinfect fabric; dim.: 196 x 193 cm; colour: grey

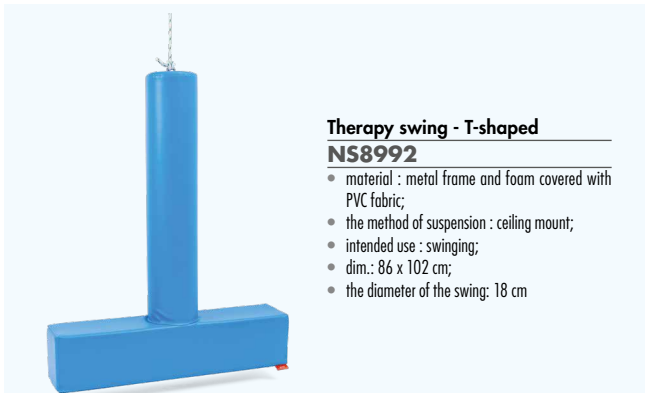

**Therapy swing - T-shaped
NS8992**

- material : metal frame and foam covered with PVC fabric;
- the method of suspension : ceiling mount;
- intended use : swinging;
- dim.: 86 x 102 cm;
- the diameter of the swing: 18 cm



Support structure for SI room available in export catalogue 2020

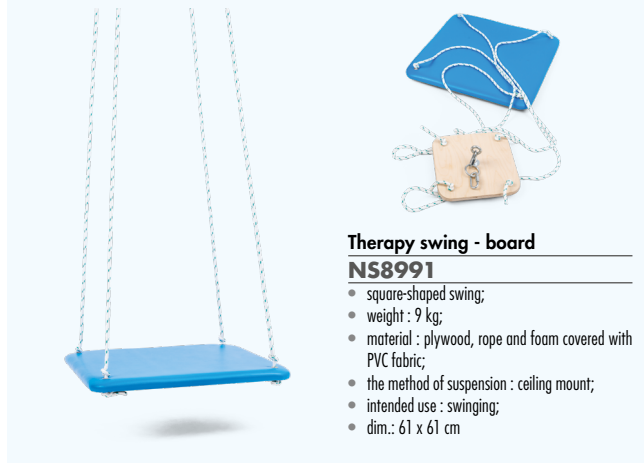

**Therapy swing - board
NS8991**

- square-shaped swing;
- weight : 9 kg;
- material : plywood, rope and foam covered with PVC fabric;
- the method of suspension : ceiling mount;
- intended use : swinging;
- dim.: 61 x 61 cm



**Double roller platform
NS9085**

Double roller platform helpful during various therapeutic activities. It is made of birch deciduous plywood.

- dim.: of one element: 134 x 64 x 17 cm;
- dim.: of two rollers joined together: 268 x 66 x 17 cm
- the dominant colour of the product is orange



**Roller platform ladder
NS9086**

Ladder designed for roller platforms. It is equipped with 5 rods on which roller platform can be mounted.

- dim.: 66,5 x 50 x 54 cm

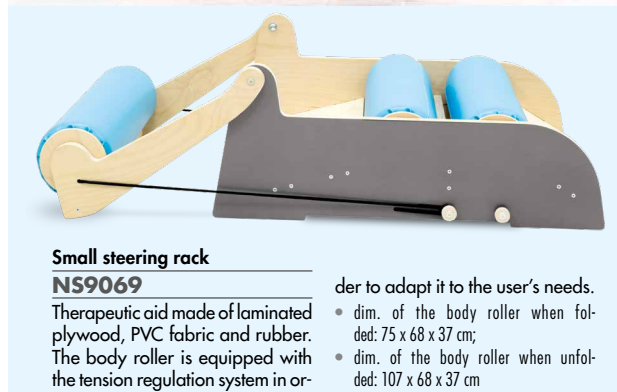

**Small steering rack
NS9069**

Therapeutic aid made of laminated plywood, PVC fabric and rubber. The body roller is equipped with the tension regulation system in or-

der to adapt it to the user's needs.

- dim. of the body roller when folded: 75 x 68 x 37 cm;
- dim. of the body roller when unfolded: 107 x 68 x 37 cm



**Infinity. Light panel
RV0012**

Magical object for stimulating the sense of sight. The panel is equipped with LED lights and a set of mirrors which create the amazing illusion of an endless tunnel. The witch-key is placed on the side of the device. Colours can be changed with the remote control. The product is delivered with a power cord and an adapter.

- dim.: 35 x 13 x 35 cm;
- powering: 220V AC;
- weight: 3 kg; age: 3+

SENSORY PATH

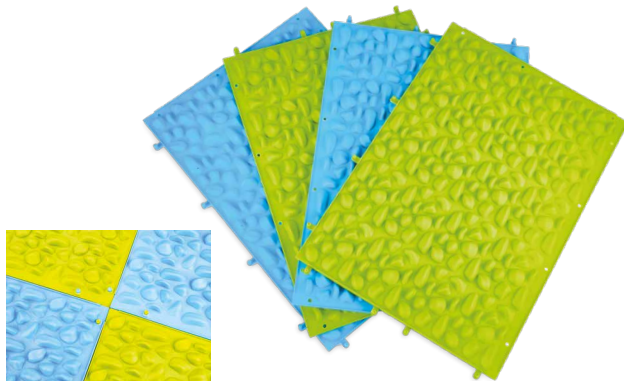

Soft sensory paths

UT0029

Sensory path with the texture in the form of small irregular stones. Two-coloured, resilient, and light panels which can be easily connected thanks to the holes and snap rivets located at the

edges of each element. The set allows children to develop sensory integration, it massages the feet and helps to correct flatfeet.

- 10 pcs.: 5 green elements, 5 blue elements; dim. of the panel: 39 x 29 cm; material: thermoplastic rubber – TPR; age: 3+

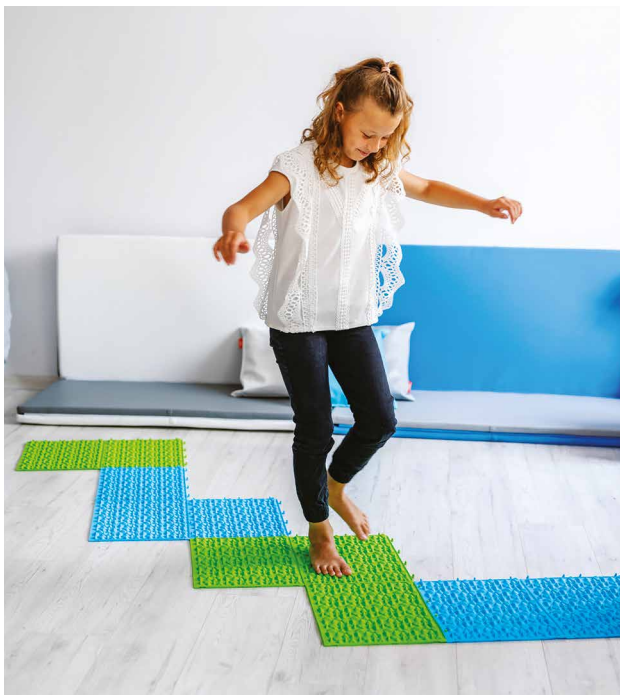

BALANCING

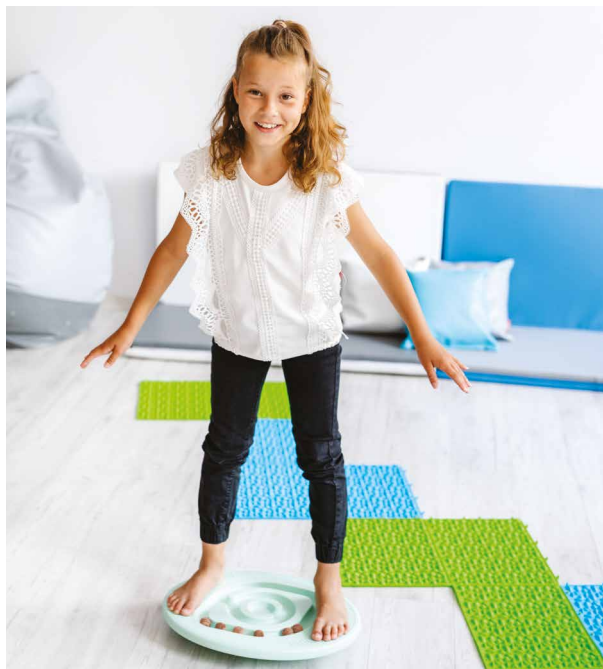

Balance plate

UT0028

Perfect aid to learn how to balance with the whole body or do exercises which train balance and motor skills. It is equipped with a maze with 5 balls. They allow children to develop their eye-hand coordination and dexterity. The surface of the balance beam has special non-slip dots which ensure safety during any activity.

- dim.: 50 x 40 cm; material: ABS; age: 3+



Arch. Path on balls

NS9189

This aid consists of a platform embedded on rubber balls. It is used for balancing and it has a positive influence on the development of the vestibular system, awareness of the body and control over it. The product is ready to use and no assemblage is necessary. However, it can be combined with other arches (NS9186) and form sensory stimulating tracks to train balance and coordination.

- dim.: 68 x 57 x 8 cm; arch 60 degrees; material: plywood, 15 mm thick, plastic



MIRRORS MINTY LINE

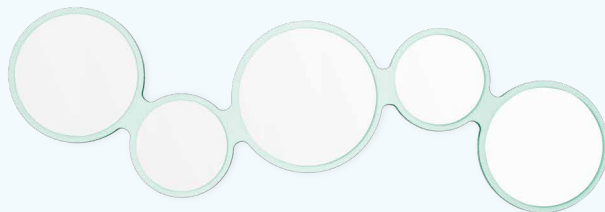

Speech therapy mirrors NS0364

The set of 5 mirrors on a shared surface. Mirrors were made of safe, solid and scratch-resistant plastic. It is a perfect tool for toddlers because it provides reflective experience of their own bodies or of various objects in the therapy of

sensory integration disorders. It can be also useful during speech therapy exercises. The set contains mounting hardware for hanging it on the wall.

- 1 x mirror with hooks; 2 x screws (6 x 6 cm; with wall plugs); dim. of the set: 100 x 30 cm; diam. of the mirrors: 1 x 23 cm, 2 x 22 cm, 2 x 15 cm; material: MDF board, 12 mm thick, in green colour, 2 mm thick mirror plexiglass

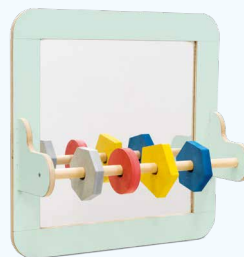

Wall mirror with an arm and manipulative elements NS9093

A mirror with a bar on which are fixed movable colourful shapes (circle, pentagon, hexagon and heptagon). The mirror frame is made of MDF board.

- dim.: 49 x 49 x 16 cm



Mirror tray NS9089

The tray has a mirror on the bottom. The walls are made of MDF board.

- dim.: 40 x 30 x 6 cm

LIGHT THERAPY

Sensory educational aids which use light to create stimulating or calming visual effects. They are perfect as a part of the school equipment as the stimulation of the sense of sight is incredibly important. Additionally, these aids help to calm down, concentrate and they develop children's curiosity during playtime or during classes.



Fiber optic tree

RV0100

LED fibre optic light creates calming and soothing atmosphere. It is perfect as a room decoration or as an aid used in the therapy of people with sensory disorders. Crystals which are placed in the based enhance visual sensations. The set contains a remote control for changing colours of the lights.

- dim. 8 x 8 x 33 cm; material: ABS; powering: 3 x AAA batteries (not included); age: 3+

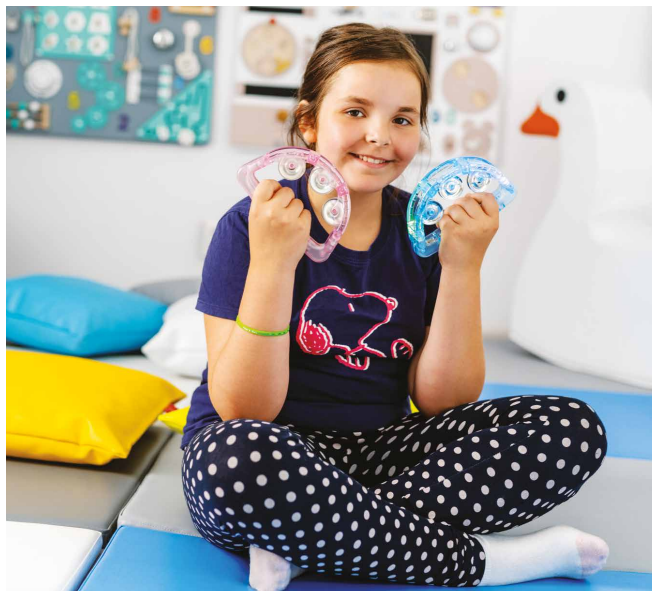

Luminous sensory tambourine

RV0050

Luminous tambourine is an amazing addition to sensory play or to rhythmic exercises. The tambourine is made of hard plastic and metal fittings with polished surface. It is light and comfortable to use. The colours emitted by the bells stimulate the sense of sight while the bells stimulate the sense of hearing.

- 1 pc.; dim.: 16 x 3,2 x 10 cm; weight: 0,1 kg; powering: 3 x AA 13 batteries; colour is picked at random; age: 3+



Illuminated interactive sandbox

RV0300

The table is designed for relaxation, tactile and visual stimulation, imagination development and therapy through play. Parts of the walls are made of beech wood. The bottom of the sandbox is made of transparent acrylic underneath which LED lighting was mounted in order to illuminate the patterns created in sand. Drawings or writing can be

made with the use of fingers, brushes or special combs. On the side of the table there are buttons thanks to which the user can change the colour of the lights. Metal legs ensure stability of the table. The sand inside the sandbox should cover the entire bottom surface (around 1-2 kg). The product is delivered with a power cord and an adapter.

- dim.: 63 x 63 x 70 cm; material: wood, metal, acrylic; powering: 220V AC; age: 3+



**Light and sound projector.
Crystal**

RV0037

Light and sound projector with the regulation of light intensity. It creates a pleasant environment. There are six modes: cold, warm, flashing, constant and pulsating light.

- battery: 1000 mAh



**Illuminated panel
of colourful cubes**

UT0035

Small touchpad made of 5 fields illuminated with different colours. It also produces a pleasant and clear sound. It allows children to play with colourful light and sound. It is a great therapeutic device which engages and stimulates sight, hearing and motion at the same time.

- dim.: 30 x 6,5 x 4,5 cm; material: PVC; powering: 4 x AAA 1,5 V batteries; instruction; age: 3+



**Illuminated mini sandbox
with sensory sand**

UT0034

Small sandbox for sensory play. It is a perfect place for creative activities. The bottom of the sandbox is made of transparent acrylic with built-in LED lighting. This combination allows children to trace the sandbox's bottom with their fingers to stimulate the sense of sight and touch. Raised walls prevent the sand from spilling during playtime. The product can be used immediately after unpacking.

- 1 x sandbox, dim.: 40 x 9 x 28 cm, 1 x brush with a dustpan, 1 x power cable, 1 x plug, 2 x sensory sand; material: PVC; powering: USB port; age: 3+

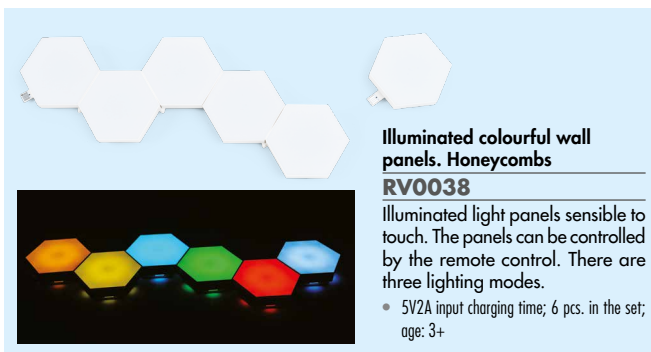

**Illuminated colourful wall
panels. Honeycombs**

RV0038

Illuminated light panels sensible to touch. The panels can be controlled by the remote control. There are three lighting modes.

- 5V2A input charging time; 6 pcs. in the set; age: 3+

THERAPEUTIC DOLLS

Big educational glove puppet 75 cm high. It is made of soft fabric. The head, mouth and hands can be moved by the hands of the person who manipulates the puppet. Perfect for diversifying the process of learning and as a play companion.



Maggie
NS2681



Brian
NS2682

MANIPULATION



Manipulative flower

NS2680

Manipulative flower made of soft fabric with many engaging parts, including: clips, buttons, hook and loops fasteners, laces and a slider.

- diameter of 50 cm, height: 10 cm



SENSORY AIDS

GEL AND SILICONE AIDS



Sensory gel solids with glitter UT0020

Set of sensory shapes which stimulate the sense of sight or touch as well as serve as an aid during manipulative exercises. We recommend combining them with illuminated panels. Soft and nice to touch elements are filled with a special gel with glitter which

creates unique patterns when pressed. All shapes are equipped with Velcro closure to give the possibility of creating 3D shapes from meshes. This product can prove useful when teaching geometry, especially in the case of children on the autism spectrum.

- 4 elements: cube, cuboid, prism, regular tetrahedron; dim.: 19 x 26 cm; material: plastic; age: 1+



Gel letters. Set UT0024

Gel alphabet is perfect for sensory play or learning how to spell. The colourful gel and the textured surface provide plenty tactile and visual sensations. All letters can be combined with illuminated panels. They prove useful during polysensory stimulation or therapy.

- 26 pcs.; height: 11 cm; material: plastic; age: 1+



Gel numbers. Set UT0023

Colourful set of textured numbers. They are perfect for stimulating the senses or for sensory play with the illuminated panel. All numbers are nice to touch and soft. Additionally, they encourage activity, stimulate curiosity and improve concentration.

- 26 pcs.; numbers: 0-9; height: 10,5 cm; material: plastic; age: 1+



Gel shapes. Set

UT0021

Shapes filled with gel balls are perfect for sensory play. Through manipulative play, squeezing and pressing children

stimulate the sense of touch. When combined with the illuminated panel, the product provides amazing visual sensations.

- 6 pcs.: circle, square, triangle, rectangle, pentagon, hexagon; material: plastic; age: 1+



Sensory flat shapes - big and small. Set

UT0022

Sensory mats for therapy or playtime in five shapes and two sizes. All big shapes have smaller round counterparts in the same colour and with the same texture. Each pair is characterised by a different pattern in order to stimulate the sense of touch of the hands and feet. They are made of durable but nice to touch material.

- 10 pcs.: 5 small shapes with the diam.: 10 cm, 5 big shapes with the diam.: 24 cm; material: silicone; age: 1+



Sensory silicone shapes

UT0025

Flexible shapes with suction cups spark creativity, inspire curiosity, improve fine motor skills and they stimulate the senses. Colourful elements can create wavy lines or chains; children can also bend or twist them as well as cling them to any flat surfaces. Each shape has a different texture in order to stimulate the sense of touch while their vivid colours stimulate the sense of sight. This set it guarantees many hours of exploratory, fascinating fun.

- 6 pcs.: shape: square dim.: 8 x 8 cm, triangle dim.: 4 x 8 cm, star dim.: 8 x 9 cm, heart dim.: 8 x 8 cm, circle diam.: 7,5 cm, rectangle dim.: 9 x 7 cm; material: silicone; age: 1+

DE-STRESSING AIDS

Colourful, soft stress relief toys in different shapes are made of special materials which allow the user to squeeze them in all possible ways. Products we offer not only develop the sense of touch, provide new stimuli and different textures, but also, they have a great influence on the development of fine motor skills. Addition-

nally, they serve as a stress reliever because they help to ease tension, anxiety, and negative emotions in a safe way. By alternating tightness and relaxation in the muscles during the use of stress relief toys, we can reduce muscle tension caused by stress and relax.



Relaxing stretchy strings

RV0200

Soft and durable strings resistant to compression and stretching. They can be used during playtime or to strengthen the arm muscles. Additionally, they might help to relieve stress and anxiety as well as improve patience. This product is especially recommended for children and adults with ADD, ADHD or on the autism spectrum.

- 6 pcs.; weight: 0,18 kg; age: 3+



Sensory bubble disc

RV0039

Bubble sensory disc in different shapes made of silicone. Bubbles make a pleasant noise when pressed. Discs can also be used when playing in pairs.

- age: 3+



Relaxing hand squeezers

UT0027

Relaxing hand squeezer provides many sensory experiences. It is made of flexible and resilient material which is durable and easy to squeeze. Soft, textured shapes are not only nice to

touch, but they also help children to calm down and relax. Additionally, hand squeezers strengthen the hand muscles.

- 4 pcs.: ball, heart, star, oval; dim.: 5-8 cm; material: thermoplastic polyester elastomer; age: 1+



Relaxing sensory hand squeezers

RV0060

Set of hand squeezers filled with liquid containing coloured beads and glitter. The toy's surface is smooth and slick which makes it challenging to keep in hand. These relaxing and manipulative hand squeezers train hand motor skills, stimulate creativity, relax, and help to calm down. Perfect for rehabilitation or SI therapy.

- 4 pcs.; dim.: 12,5 x 3 x 3 cm; age: 3+

BALLS



Hard sensory balls RV0010

Sensory half balls improve dynamic balance and body awareness. They help to relieve stress and improve blood circulation. Additionally, they can be used to develop coordina-

tion, endurance and to train various muscle groups. Perfect for massage, especially foot massage. Suitable for children and adults.

- 8 pcs.; diam.: 16 cm; 8 colours: yellow, orange, red, green, blue, navy blue, silver, pink; material: plastic; age: 3+



Textured rubber balls UT0038

Sensory half balls improve dynamic balance and body awareness. They help to relieve stress and improve blood circulation. Additionally, they can be used to develop coordination, endurance and to train various muscle groups. Perfect for massage, especially foot massage. Suitable for children and adults.

- 8 pcs.; diam.: 16 cm; 8 colours: yellow, orange, red, green, blue, navy blue, silver, pink; material: plastic; age: 3+



Pastel sensory balls. Set RV0070

Eye-catching soft balls of various shapes and textures. They are perfect for babies and toddlers for improving motor and manipulative skills or for stimulating the sense of touch. These balls are crush and water resistant. They are made of BPA free material.

- 6 pcs.; diam.: around 6,5 cm; 6 pastel colours: 2 shades of green, yellow, purple, blue, nude; material: silica gel; age: 6 months +



TEXTURES



Textured pads in a bag UT0030

Set of 10 pairs of square patches with various textures. Each patch is different, and this trait allows children to engage in sensory play through matching, discovering and describing their textures. The set includes a bag inside which children can not only store patches, but also introduce an element of

randomness to their playtime. The activity with the set provides many sensory experiences, it improves concentration and focus in children, and enriches their vocabulary.

- 20 pcs.; dim.: around 5 x 7,5 cm; material: 2 x polyurethane, 2 x nylon; 2 x non-slip fabric, 2 x satin, 2 x wool, 2 x plush, 2 x fabric with embossed stripes along the fabric, 2 x terry cloth, 2 x Velcro material, 2 x shiny fabric; filling: cut pieces of EVA foam, cotton; age: 1+



Fish. Stilts

UT0039

Fish-shaped stilts. Perfect aid in training the hand-foot coordination as well as the balance. They are made of durable plastic.

- colour: green; dim.: 21 x 15,5 x 8 cm; age: 3+



Sensory cactus

UT0026

Set of silicone rings with wooden base. The goal of the toy is to create a colourful cactus. Each side of the sensory element has a different kind of sensory dots which encourage children to study their surface and to express their ideas through play. All rings have a special indentation in order to easily combine the elements of the set. This toy is made of coloured and textured materials to stimulate the sense of touch and sight.

- 9 pcs.: 8 sensory elements, diam.: from 7,5 cm to 9,3 cm, 1 base, diam.: 10 cm; material: silicone, wood; age: 2+



MUSICAL AIDS



Geometric rattles NT0150

Set of rattles which stimulate the sense of hearing. All instruments in various colours and shapes produce different sounds. Perfect for playing and discovering the world through the senses of touch, hearing and sight.

- 3 pcs.: shapes: square, triangle, cylinder;
- dim.: 5 x 2,5 x 5 cm; material: plastic;
- age: 12 months +



PATHES

Sensory bricks US0529

Construction elements for building various structures. Sensory bricks can be arranged freely one on top of the other. Playtime with bricks helps to develop small motor skills and spatial imagination. Different textures of the elements additionally stimulate the sense of touch.

- 32 pcs., 4 shapes and 4 colours;
- material: plastic;
- age: 3+



MANIPULATION

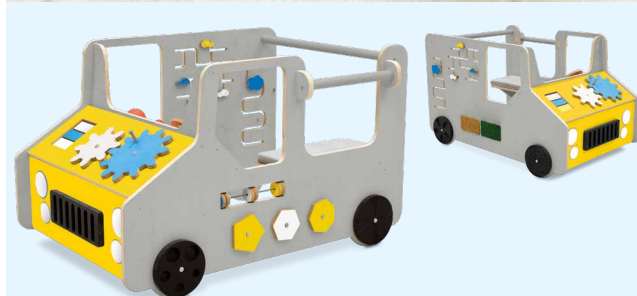

Manipulative school bus NS9087

A bus made of plywood offering many options of creative and engaging manipulative play. Among the movable parts, there are colourful, big gears, colourful rotating elements with mirrors on the other side, differently shaped labyrinths, a steering wheel and a gear-

box. Additionally, the bus is equipped with textural fragments and mirrors. Inside, there is a comfortable, soft seat in grey colour attached with Velcro. This manipulative bus awakens curiosity in children thanks to the movable parts and it develops their imagination through playtime involving roleplay.

- dim.: 110 x 65 x 70 cm



Manipulative castle

NS9088

A castle made of plywood offering many options of creative and engaging manipulative play. Among the movable parts, there are gears, an opening window with the possibility of closing it, rotating elements, differently shaped labyrinths and a mesh above

the castle's entrance. Additionally, the castle is equipped with textural fragments and mirrors which stimulate the sense of sight. This manipulative castle awakens curiosity in children thanks to the movable parts and it develops their imagination through playtime involving roleplay.

• dim.: 75 x 110 x 75 cm



SPORT EQUIPMENT

BEAN BAGS



Bags filled with nice to touch plastic balls with embroidered inscriptions to help children learn to read and memorise the days of the week, months and seasons of the year. They are perfect for active learning how to read or sort. Their vivid colours make them interesting to look at, and they encourage children to play with them. Thanks to the embroidered inscriptions, the bags are long-lasting and they don't loose their educational value.



Bean bags - season of the year.
Polish-English version

NS2672

• dim.: 10 x 13 cm



Bean bags - days of the week.
Polish-English version

NS2670

• dim.: 10 x 13 cm



Bean bags - months of the year.
Polish-English version

NS2671

• dim.: 3 x 7 cm





**Pogo jumping stick
BO0011**

Pogo jumping stick in vivid colours. It is made of foam. Perfect for playing, exercising or competing.

- age: 3+



**Wooden serso
CI4630**

Wooden Serso game. It is an arcade game consisting of throwing a circle on a protruding element from the board. Thanks to the fact that the board is movable, the game is not repetitive.

- dim.: 36 x 36 x 16 cm; age: 3+



TUNNELS & TENTS



more tents available in
export catalogue 2020

**Surprise hideout
with a tunnel and a pool
DW8188**

Round tent, pirate themed.

- fabric: 100 % polyester, mesh: polyester, poles: fiberglass; dim.: 105 x 125 cm

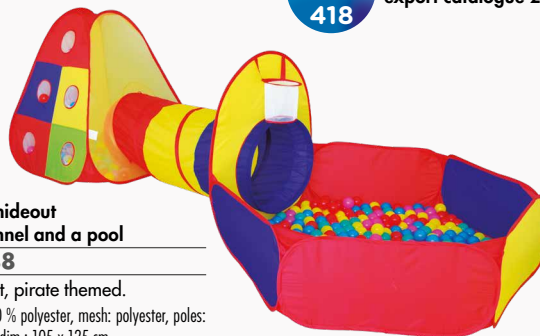

**Space. Tent with a tunnel
DW8198**

Space tent consisting of a tent and a tunnel leading inside. The tent is reinforced with a flexible steel wire.

- fabric: 100 % polyester; dim.: 165 x 95 x 85 cm



**Pirates. Round tent
DW8735**

Round tent, pirate themed.

- fabric: 100 % polyester, mesh: polyester, poles: fiberglass; dim.: 105 x 125 cm





Methodological guide.
Fun with the parachute and play tunnels. Polish-English version

NS1372

Polish-English guide created to collect playtime ideas with the parachute and tunnels. This publication contains 40 playtime ideas divided into months and weeks. In the months from September to June, we will find 4 games for each month: two propositions with the parachute, one with the parachute and tunnels, and one proposition with tunnels. The last part of the guide consists of 5 playtime scenarios. 1 with the parachute, 1 with the parachute and tunnels, and 1 with tunnels. These ideas were prepared with preschool and primary school teachers in mind as well as those working in after-school clubs. However, all activities can be introduced during kindergarten and school events such as picnics, competitions, open days, etc.

• author: Dagmara Marczak; Polish-English version; publication consists of 32 double-sided A4 pages, packed in a cardboard box with a plastic blister

List of ideas by months:

- 1. September: Hello School/Kindergarten! (the parachute), Holiday Memories (the parachute), Safe at school/kindergarten, on the roads and on the streets (the parachute and the tunnel), The colours of Autumn (the tunnel);
- 2. October: Safety Week (the parachute), The School Community (the parachute), The culture of everyday life (the parachute and the tunnel), My pet (the tunnel);
- 3. November: Remembering those who have passed (the parachute), My Country (the parachute), Gifts of Autumn (the parachute and the tunnel), World Teddy Bear Day (the tunnel);
- 4. December: Hello Santa Clause! (the parachute), Christmas decorations (the parachute), Let's be tolerant! (the parachute and the tunnel), The Magic of Christmas (the tunnel);
- 5. January: Let us start the New Year! (the parachute), Fun and Safe Winter Break (the parachute), Grandma and Grandpa (the parachute and the tunnel), Snow is falling (the tunnel);
- 6. February: Helping animals during winter time (the parachute), Carnival to the rhythm of samba (the parachute), Valentine's Day (the parachute

and the tunnel), In the world of fairy tales (the tunnel);

- 7. March: Early Spring (the parachute), Friendship and respect in our lives (the parachute), Health and Hygiene (the parachute and the tunnel), Spring is Here! (the tunnel);
- 8. April: Riddles and Brain Teasers (the parachute), Easter traditions (the parachute), Earth Day (the parachute and the tunnel), Making music fun (the tunnel);
- 9. May: I'm an European (the parachute), Internet ABC's (the parachute), When I Grow Up – Occupations and Work (the parachute and the tunnel), My Family (the tunnel)
- 10. June: All children are ours (the parachute), Big trips, small trips (the parachute), My city (the parachute and the tunnel), My holidays (the tunnel);

Scenarios:

- 1. Holidays by the lake (the parachute),
- 2. Take care of our planet (the parachute and the tunnel),
- 3. Fairytale Day (the tunnel).

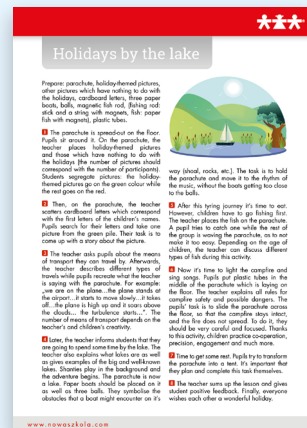

NEW COLOURS

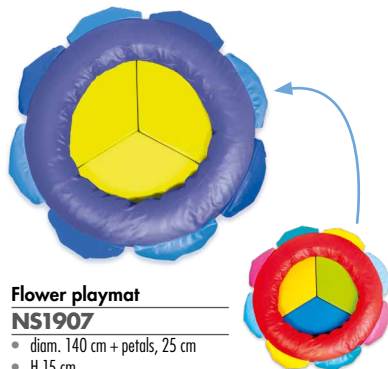

Flower playmat
NS1907

- diam. 140 cm + petals, 25 cm
- H 15 cm



Bee playmat
NS1908

- length: 135 cm; width: 115 cm (without wings); height: 10 cm



Dolphin.
Living room furniture set
NS0598

- table, dim. 67 x 36 x 24 cm
- 2 chairs, dim. 48 x 55 (height: 24 cm)



Maxi armchair Olaf
NS0596

- 55 x 45 x 55 cm
- seat H 25 cm

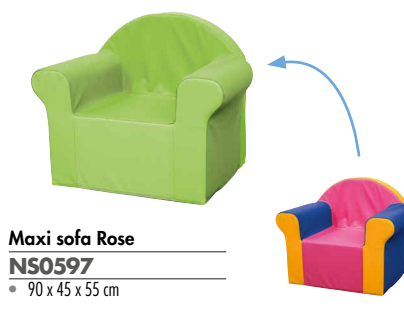

Maxi sofa Rose
NS0597

- 90 x 45 x 55 cm

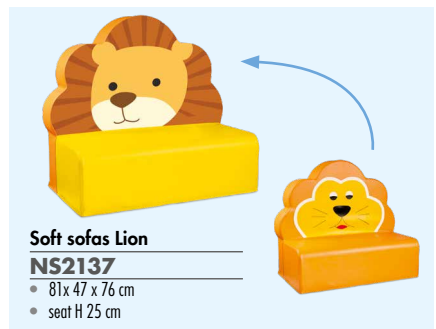

Soft sofas Lion
NS2137

- 81 x 47 x 76 cm
- seat H 25 cm



Cap with stem
NS0150

- H 120 cm

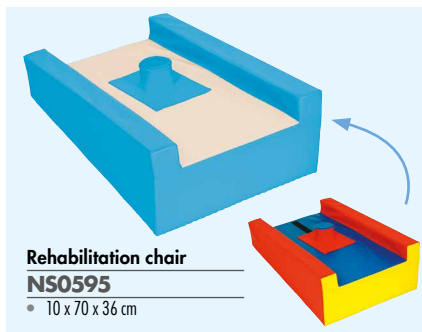

Rehabilitation chair
NS0595

- 10 x 70 x 36 cm



Mattresses
NS0554

- 150 x 100 x 5 cm (single mattress),
- 150 x 200 x 5 cm when joined)

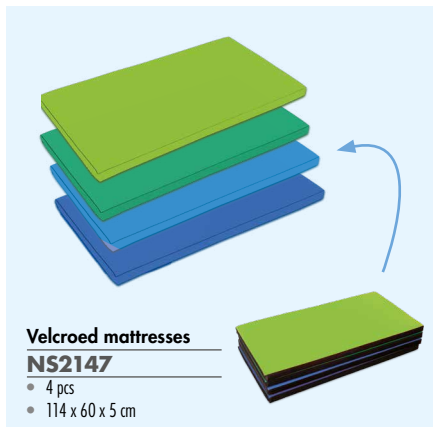

Velcroed mattresses

NS2147

- 4 pcs
- 114 x 60 x 5 cm

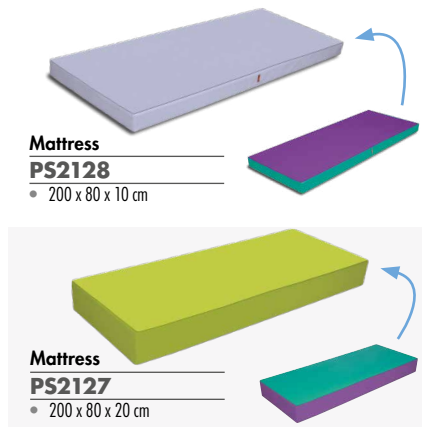

Mattress

PS2128

- 200 x 80 x 10 cm

Mattress

PS2127

- 200 x 80 x 20 cm

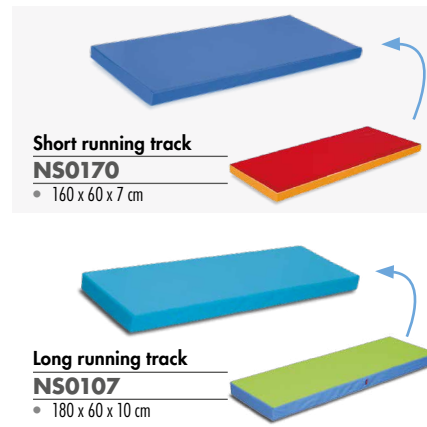

Short running track

NS0170

- 160 x 60 x 7 cm

Long running track

NS0107

- 180 x 60 x 10 cm



Mega blocks

PS2105

A set of giant softplay blocks coated with durable PVC fabric. The various sizes provide numerous possibilities for building castles and hiding places. They can also be used in rehabilitation exercises.

- 8 elements – 90 x 30 cm
- 10 elements – 30 x 30 cm
- 1 element – ø 60 cm
- pvc phthalate free
- 19 elements



Hyper blocks

NS0435

A set of giant softplay blocks coated with durable PVC fabric. The various sizes provide numerous possibilities for building castles and hiding places. They can also be used in rehabilitation exercises.

- smallest piece 20 x 20 x 20 cm
- largest piece 120 x 40 x 40 cm
- 30 elements
- various sizes
- pvc phthalate free



**Kaytek
NS0224**

- 10 items made from foam, covered with PVC fabrics, required surface: min. 4 m2



**Kaytek Base with beams
NS0227**

- base 60 x 70 x 40 cm
- 2 beams 20 x 20 x 60 cm

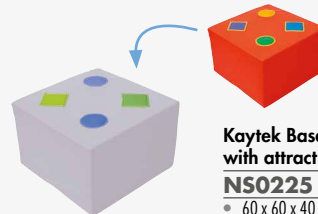

**Kaytek Base with attractions
NS0225**

- 60 x 60 x 40 cm

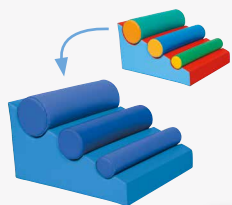

**Kaytek Base with cylinders
NS0226**

- 60 x 60 x 40 cm
- 3 cylinders: ø 10, 15, 20 cm
- base 60 x 70 x 40 cm
- 4 elements

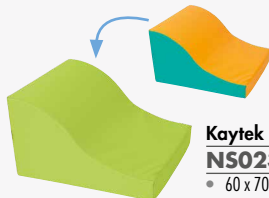

**Kaytek slide
NS0232**

- 60 x 70 x 40 cm

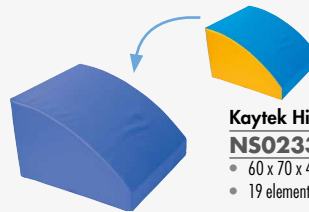

**Kaytek Hill
NS0233**

- 60 x 70 x 43 cm
- 19 elements



**Novamus
NS0125**

- 11 elements for building assault courses
- 250 x 250 x 150 cm
- waterproof anti-slip surface
- 11 elements

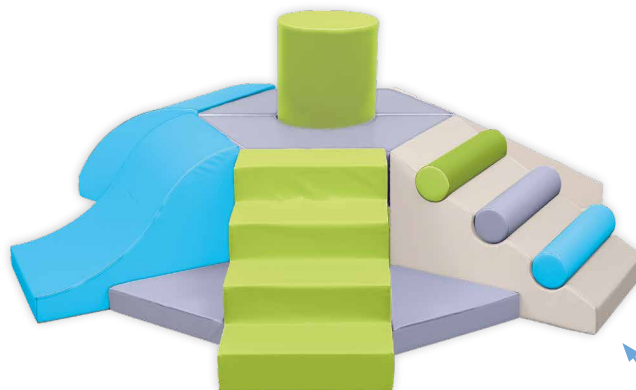

**Big Novamus
NS0128**

- 19 elements made of foam covered with PVC fabric
- 284 x 284 x 60 cm
- 100 cm in the highest point



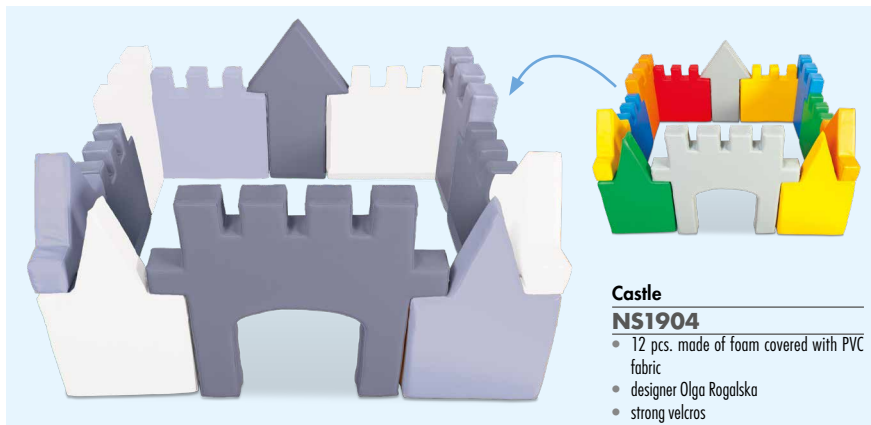

Castle

NS1904

- 12 pcs. made of foam covered with PVC fabric
- designer Olga Rogalska
- strong velcros

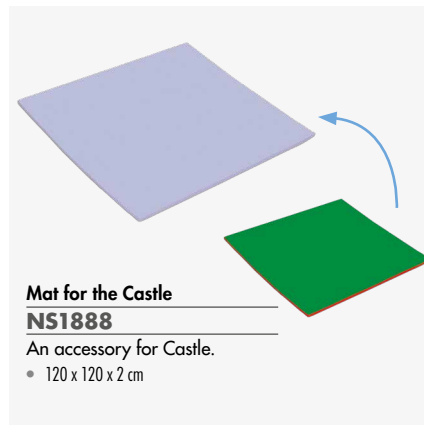

Mat for the Castle

NS1888

An accessory for Castle.

- 120 x 120 x 2 cm

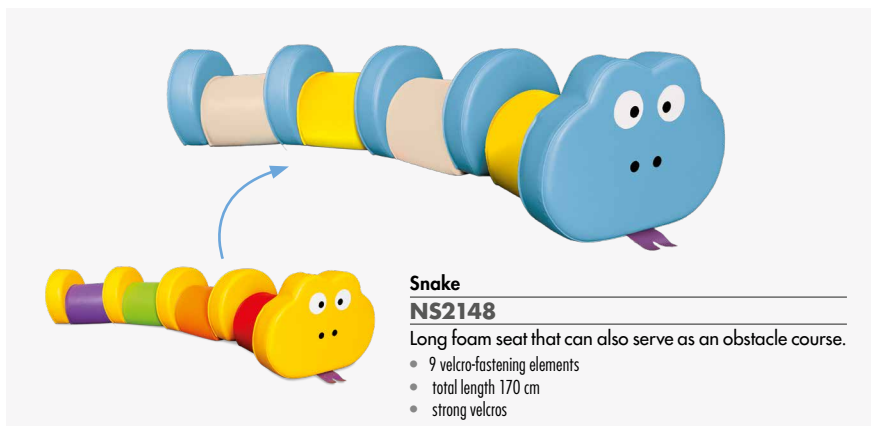

Snake

NS2148

Long foam seat that can also serve as an obstacle course.

- 9 velcro-fastening elements
- total length 170 cm
- strong velcros



LULA small pillow

NS1909

- 50 x 50 cm



LULA square pillow

PS2126

- 120 x 120 x 30 cm



LULA roller

NS1910

- ø 120, L 20 cm



LULA round pillow

NS1911

- ø 120, H 30 cm

EDUCATION

INTERACTIVE MONITORS





NS9265

Display/resolution:	4k 3840x2160
Panel/diagona:	D-LED /65"
Model:	65DL-AL
Frame:	black metal
Contrast:	5000:1
Brightness	350cd/m2-20
Aspect ratio	16:9
Reaction time:	8 ms
Colour depth:	10 Bit; 16:7M
Screen size [mm]:	1428 x 804
Screen:	4 mm frosted glass, a hardness of 7 on the Mohs scale
Viewing angles:	178°
Lifespan:	50 000 h
Touchscreen technology:	infrared radiation (IR)
Reaction time:	5 ms
Touch points:	20
Precision:	<1 mm
Writing mode:	200 dot/s
Operating system:	Android 8.0; Windows 10 after the installation of OPS

Ports:

Input HDMI port: 3XHDMI, Output HDMI port: 1xHDMI, Input DisplayPort: 1xVGA, 3XHDMI, 1XAV(MINI 3in1), 1XYPbPr(3in1), VGA input port: 1x AVG, 1x MIC, AV input: 1XAV(MINI 3in1), AV output: 1 x AV Out, USB ports (back): 2XUSB2.0, USB ports (front): 2XUSB2.0+1XUSB3.0, USB port of the touch interface: 2XUSB TYPE-B FOR EXTERNAL PC/HDMI OUTPUT, serial ports: 1XRS232, LAN ports (RJ45): 1XRJ45, Built-in speakers: 2 x 15W, Headphone output: 1 x 3.5 mm minijack, Digital output: 1xDigital Coaxial, OPS: 1XOPS SLOT, Card reader: 1XSD CARD READER, PLUG & PLAY: YES

Built-in camera:	YES/8 Mpix
Wi-Fi:	IEEE802.11a/b/g/n Dual Band 2.4GHz/5GHz or IEEE802.11an 2.4GHz
Weight:	47 kg
Dimensions:	1731 x 1037 x 111 mm
Power supply:	AC 220-240 V 50/60 Hz
Power supply unit:	320W
Certification:	CE, ROHS, ISO 9001, ISO 14001



NS9275

Display/resolution:	4k 3840x2160
Panel/diagonal:	D-LED /75"
Model:	65DL-AL
Frame:	black metal
Contrast:	5000:1
Brightness:	350cd/m2-20
Aspect ratio:	16:9
Response time:	8 ms
Colour depth:	10 Bit; 16:7M
Screen size [mm]:	1650 x 929
Screen:	4 mm frosted glass, a hardness of 7 on the Mohs scale
Viewing angles:	178°
Lifespan:	50 000 h
Touchscreen technology:	infrared radiation (IR)
Response time:	5 ms
Touch points:	20
Precision:	<1 mm
Writing mode:	200 dot/s
Operating system:	Android 8.0; Windows 10 after the installation of OPS

Ports:

Input HDMI port: 3XHDMI, Output HDMI port: 1xHDMI, Input ports DisplayPort: 1xVGA, 3XHDMI, 1xAV(MINI 3in1), 1xYPbPr(3in1), VGA input port: 1x AVG, 1x MIC, AV input: 1xAV(MINI 3in1), AV output: 1 x AV Out, USB ports (back): 2XUSB2.0, USB ports (front): 2XUSB2.0+1XUSB3.0, USB port of the touch interface: 2XUSB TYPE-B FOR EXTERNAL PC/HDMI OUTPUT, serial ports: 1XRS232, LAN ports (RJ45): 1XRJ45, Built-in speakers: 2 x 15W, Headphone output: 1 x 3.5 mm minijack, Digital output: 1xDigital Coaxial, OPS: 1XOPS SLOT, Card reader: 1XSD CARD READER, PLUG & PLAY: YES

Built-in camera:	YES/8 Mpix
Wi-Fi:	IEEE802.11a/b/g/n Dual Band 2.4GHz/5GHz or IEEE802.11an 2.4GHz
Weight:	60 kg
Dimensions:	1731 x 1037 x 111 mm
Power supply:	AC 220-240 V 50/60 Hz
Power supply unit:	240W
Certification:	CE, ROHS, ISO 9001, ISO 14001

OPS with Intel Core i5, Windows 10 Home
NS9215

- CPU: Intel® Core™ 5 generation i5-7400 3.00 GHz (3.50 GHz in Turbo mode) processor; Intel® H110 RAM: 4GB DDR4-2400 SO-DIMM, 1x hard drive 128 GB SSD M.2, 1 x SATA connector: HDMI x1; VGA x1; DP x1; USB 3.0 x6; Ethernet (10/100/1000 MB) / Wi-Fi 802.11ac (2.4 GHz / 5 GHz) with 2 external antennas; RJ45 x1; headphones output 3,5 mm; microphone input 3,5 mm; Bluetooth 4.0

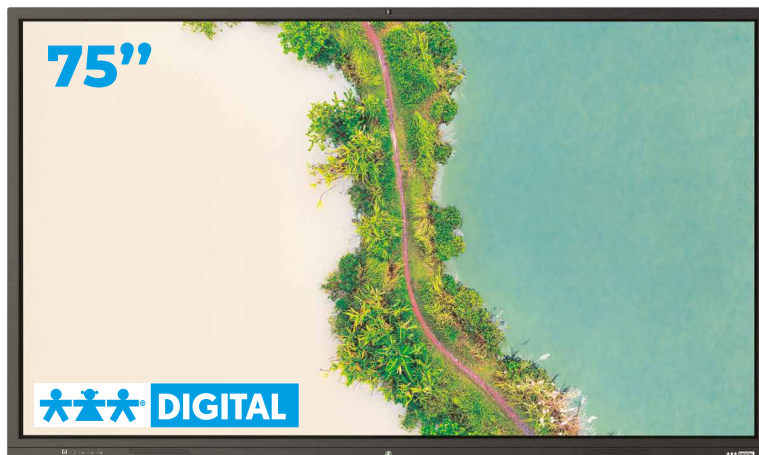

3D PRINTER CABINET



3D PRINTER IS COMING SOON.
ASK EXPORT DEPARTMENT
FOR MORE DETAILS

Cabinet for 3D printers and filaments

BAL0001

- printer stand with a cabinet for the printer and filaments; it is made of furniture board, 18 mm thick, in birch colour and MDF board, 12 mm thick, in grey colour; the stand is equipped with 6 deep plastic containers, 3 white and 3 grey, as well as a pair of doors with a lock; inside the stand, there are two shelves; 3 filament holders and 2 side limiters for the printer are placed on the back wall; beige plastic legs, 5 pcs., can be replaced with furniture castors, sold separately – NJ0904; dim of the stand: 103,7 x 57 x 181,8 cm; tabletop height: 104 cm



Cabinet for 3D printers and filaments

BAL0002

- cabinet made of birch and grey chipboard with three hooks for filaments; a pair of lockable doors; lockable cabinet inside has a shelf; the furniture has five legs for strength and stability of the structure; the set includes three plastic containers with lids in a color mix; dimensions: 92 x 53 x 173 cm, top height: 101 cm



MANIPULATIVE BOARDS

Boards equipped with simple but functional elements encouraging manipulative play. Additionally, they are enriched with sensory tools which help children to develop creativity, logical thinking, perseverance, eye-hand coordination, and motor skills. Through play, children also learn new skills necessary in everyday life.

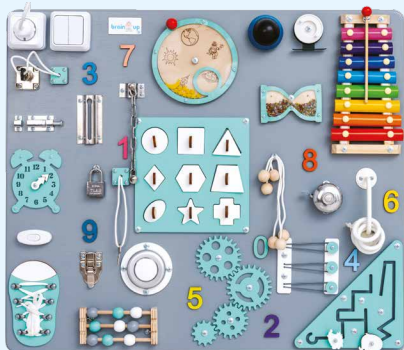

Manipulative board. Grey

RV0350

- dim.: 60 x 8 x 40 cm; weight: 4,5 kg; material: birch plywood in grey colour; manipulative elements: lace-up shoe, xylophone, different locks, switches, wooden clock, shape matching game with Velcro, zip, belt with Velcro, board with patterns, labyrinth with an owl, mini abacus, beads on a string; age: 3+

Manipulative board. Turquoise

RV0360

- dim.: 60 x 8 x 70 cm; material: birch plywood in turquoise colour; manipulative elements: lace-up shoe, xylophone, different locks, latch, bell, switches, wooden clock, shape matching game with Velcro, zip, belt with Velcro, board with patterns, labyrinth with an owl, wooden balls on a string, gears, mini abacus, numbers 0-9, hourglass with beads; age: 3+

Manipulative board. White

RV0370

- dim.: 60 x 8 x 70 cm; material: birch plywood in turquoise colour; manipulative elements: wooden clock, xylophone, different locks, light, numbers 0-9, 2 x shape matching game with Velcro, game with rotating beads, game with rotating images, lace-up shoe, manipulative labyrinth, chalkboard, zip, belt with Velcro, locking system, bell, wooden sensory balls; age: 3+

BEARS



Manipulative boards in the shape of an adorable bear which offer different manual activities. The presence of moving parts promotes child's development and stimulates their senses.

They not only help children to improve their logical thinking, visual and motor coordination, but also develop independence and increase concentration.



Manipulative board with optics

VG4551

- dim.: diam.: 30 cm; moving parts: 3 discs with prints; fitting elements: 2 x screws, 2 x wall plugs; material: wood; age: 18 months +



Manipulative board with gears

VG4553

- dim.: diam.: 30 cm; moving parts: 5 gears, 3 fans; fitting elements: 2 x screws, 2 x wall plugs; material: wood; age: 18 months +



Manipulative board. Rainbow

VG4555

- dim.: diam.: 30 cm; moving parts: disc with colours; fitting elements: 2 x screws, 2 x wall plugs; material: wood; age: 18 months +



Caterpillar. Manipulative board

VG4557

Multifunctional Caterpillar board equipped with many manipulative elements which train the eye-hand coordination of the youngest. The board is divided into 5 parts. Each of them encourages children to be active in different ways. The caterpillar's head has got a winding track for moving wooden beads. Next, there is a part with reels that provide

interesting visual effects depending on the speed at which the board spins. The third part introduces the subject of derived colours, created by mixing primary colours. Then, there is a part with small doors. Inside are hidden materials with different texture, like: Velcro, mirror, felt fabric. The last part consists of a labyrinth track with the possibility of connecting elements with each other. When combined, they turn into gears.

- dim.: 185 x 12 x 83 cm; age: 3+



MAGNETIC BOARDS

Rich sets of magnetic puzzles which, when arranged, form colourful depictions of fruits, vegetables, animals, or vehicles. Each product consists of 8 four-piece puzzles. Their additional advantage is the possibility to arrange the puzzles on any magnetic surface. These

puzzles are a great way to improve concentration, logical thinking and motor skills. Each set contains a cotton bag to store the puzzles.

- 32 pcs; dim.: 4 x 1 x 4 cm; material: wood, magnet; cotton bag; age: 18 months+



magnetic boards available in export catalogue 2020

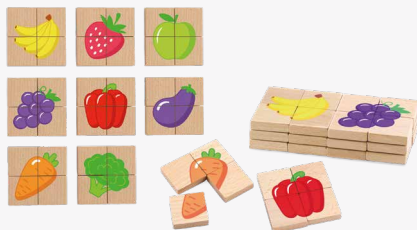

Fruits and vegetables

VG0700

- 8 four-piece puzzles: bananas, strawberry, apple, grape, pepper, aubergine, carrot, broccoli



Vehicles

VG0723

- 8 four-piece puzzles: railway engine, rocket, helicopter, ship, fire truck, police car, ambulance, plane



Animals

VG0722

- 8 four-piece puzzles: sheep, cow, horse, rooster, lion, monkey, crocodile, elephant

Symmetry bricks with worksheets

VG0642

Magnetic bricks perfect for fun games on the board. Thanks to the 20 boards with 40 images of possible bricks arrangements, children can improve their problem-solving skills, critical thinking and creativity. The set is kept in a cotton bag to prevent its elements from getting lost or damaged.

- age: 3+

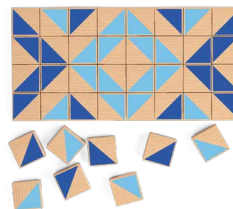

EARLY YEARS

WOODEN TOYS



My first telephone

CI3627

My first telephone is a fantastic toy which stimulates toddlers' imagination. To play pleasant tunes, children should press buttons and to call, they should shake the phone. The toy has a mirrored front in which children can see their reflection. Activity with the telephone develops the ability to communicate and awakens cognitive curiosity.

- dim.: 6,5 x 2 x 16 cm; 3 LR44 batteries are necessary (not included); material: wood; age: 10 months +



My first camera

CI3634

Classic camera equipped with a lens, a red shutter button and a flash lamp imitation. The lens in the form of a checked glass multiplying the image which can be set in motion by turning the lens ring. Thanks to this, it is possible to obtain a kaleidoscopic effect. This toy develops imagination, creativity, manual and cognitive skills. A wrist strap prevents the camera from falling.

- dim.: 15 x 7,5 x 5 cm; material: wood; age: 10 months +



Wooden toy pusher Robot

CI0515

Robot is a great companion of children starting to learn to walk. It is equipped with 4 wheels and a height regulating handle which can be adapted to the child's height. Magnetic arms can be set in several positions. The toy pusher has many manipulative elements, for example: moving eyes, xylophone, 3D shapes sorter, gears, mirror, spatial labyrinth. Thanks to the regulated speed limiter the product is safe to use. Open glove compartment allows children to store their trinkets or toys. The pusher trains small and large motor skills.

- 5 pcs.: 4 bricks, 1 pusher dim.: 30, 7 x 35,5 x 47,9 cm;
- material: wood, MDF board; age: 1+



Wooden train

on a string

CI0508

The train consists of 17 bricks in different shapes and colours. Each car has a different shape. Laser engraved texture on the manipulative elements additionally stimulates the sense of touch and supports cognitive development in children. Removable shapes develop creativity

and improve fine motor skills. Toddlers can freely arrange the bricks in order to design their own train. Wooden bricks allow children to develop manual skills, spatial imagination and the ability to create their first constructions. A string included in the set facilitates the movement of the train.

- dim.: 42,7 x 7,5 x 11,8 cm; 17 bricks; material: wood; age: 1+





**Wooden three-level puzzle.
Body in motion**

CI0031

Three-level puzzle helps children to learn the secrets of the human's anatomy. Each level presents a different part of the human's anatomy. It shows skeletal system and the muscular system with the internal organs. Among

the puzzles there are also tiles with images of children performing various activities. This is a fantastic aid which will introduce children to the world of anatomy as well as develop eye-hand coordination, logical thinking and fine motor skills.

- 19 pcs.: 18 puzzles, 1 base dim.: 30 x 30 x 1,2 cm;
- material: wood; age: 1+



**Manipulative trees
CI0102**

Three adorable trees and animals which live on them: owl, woodpecker, squirrel. Elements of the set can be freely combined in order to create different shapes. The bricks can be arranged on the base with a rod or on a flat surface. This toy helps to develop visual-motor coordination, logical thinking and recognition of shapes and colours.

- 16 pcs., 1 base, 15 bricks; dim.: 23 x 8 x 12,4 cm; material: wood; age: 1+



**Little fisherman.
Wooden dexterity toy
CI0111**

Rich set of elements, including magnetic ones, which offer 3 kinds of activity. Happy seal with fish allows children to train dexterity. The task is to place as many fish as possible on the seal's back. The seal has holes in the side wall with rods of various lengths inside them to create a sorter for layering fish. Additionally, such an activity develops fine motor skills and logical thinking. Pond in the form of a round pad, magnetic fishing rods and fish allow children to organise a fishing contest.

- 24 pcs.: 1 seal/ sorter base, 5 rods, 15 magnetic fish, 1 pond, 2 fishing rods; material: wood, magnet; age: 18 months +



**2in1 walker-pusher
CI0509**

Walker-pusher in beautiful pastel colours equipped with two handles and manipulative elements: sorter, gears, puzzles and mini labyrinth. Long handle on the back of the vehicle is used to drive the pusher which makes it easier for children to take their first steps. The

other handle on the front ensures safety while driving. On the sides of the walker-pusher are holes in different shapes, corresponding to the bricks included in the set. This product supports motor development and improves eye-hand coordination. Wooden frame with rounded edges guarantees safe playtime.

- dim.: 47 x 22,5 x 42 cm; 4 bricks included in the set; material: wood; age: 18 months +



**Balancing frogs
CI0098**

Colourful wooden arcade game which guarantees many hours of great fun. The children's task is to alternately place the frogs on a balancing water lily in such a way as to keep it in balance for

as long as possible. This game develops eye-hand coordination and motor skills. It also improves concentration, patience and dexterity.

- 1 balancing base
- dim.: 18 x 18 x 7,5 cm, 8 frogs,
- 1 flower; material: wood; age: 10 months +



**Wooden tower
with animals and numbers
CI3567**

Colourful set of cardboard boxes in different sizes which enable multi-variant fun and support the development of children. This set can be used to build towers or learn numbers, first math concepts and even animal names. It develops motor skills, imagination, creativity and language skills.

- 10 boxes in different sizes; dim.: of the tower: 15,5 x 15,5 x 110 cm; material: cardboard; age: 18 months +

PUZZLES



Sets of four-piece theme puzzles for toddlers. The themes including animals and vehicles, vivid colours as well as child-safe shapes inspire manipulative play. All illustrations and forms are adapted to the age and capabilities of children.

Play time with the set's elements encourages learning about the world, it trains fine motor skills, perceptiveness and imagination. The puzzles are made of thick cardboard.

- 24 pcs.; age: 18 months +



Set of cardboard jigsaw puzzles. Farm animals

CI0026

- 6 puzzles: sheep, duck, chicken, horse, cow, pig



Set of cardboard jigsaw puzzles. Forest animals

CI0027

- 6 puzzles: lion, bear, owl, koala, fox, elephant



Set of cardboard jigsaw puzzles. Vehicles

CI0024

- 6 puzzles: fire truck, ambulance, railway engine, school bus, police car, pickup truck; material: cardboard;



The set contains 5 different outfits which can freely mixed and matched. Playing with this set allows children to develop

their motor skills and it boosts their creativity.



Dress-up game Occupations. Girl

CI0117

- there are 28 elements inside; dim.: 65 x 20 x 0,5 cm

Dress-up game Occupations. Boy

CI0118

- there are 27 elements inside; dim.: 65 x 20 x 0,5 cm



Ocean. Wooden puzzle

CI0028

Playtime with colourful elements of the puzzle teaches children to identify different sea animals and geometrical shapes. This toy supports the development of eye-hand coordination and the ability to solve problems.

- 13 pcs.: 12 puzzles, 1 base
- dim.: 30 x 21 x 1,2 cm;
- material: wood; age: 1+



Forest. Wooden puzzle

CI0030

This puzzle helps to learn to recognise various forest animals and geometric shapes. It develops eye-hand coordination and the ability to solve problems.

- 13 pcs.: 12 puzzles, 1 base
- dim.: 30 x 21 x 1,2 cm;
- material: wood; age: 1+



Wooden puzzle - bear

CI0100

Classic wooden puzzle in the form of an adorable tower with a teddy bear. It is designed with four colourful and effective rings as well as the lovable teddy bear's

head. Through arranging the puzzle's elements children learn to organise objects according to their size, they improve logical thinking, dexterity and the ability to identify colours.

- 6 pcs.: base with a rod, 5 bricks; dim.: 8,5 x 8,5 x 13,5 cm;
- material: wood; age: 1+

ROLE PLAY

KITCHEN



Chef's cooker CI4201

A wooden cooker with accessories thanks to which little cooks can prepare delicious meals. The size of the cooker allows two children to play at the same time. This set encourages the development of motor skills, it boosts creativity and teaches children how to plan their actions.

- dim.: 53 x 31 x 73,5 cm; age: 3+



Grey wooden cooker with accessories VG4049

A cooker with accessories. The cooker is equipped with an oven, a sink, a clock and two burners. Among the included accessories are a pan with a fried egg, a saucepan, a spatula, a spoon and two jars of spices. While playing with this set, children learn how to be organised and tidy.

- dim.: 47,5 x 70 x 30 cm; age: 3+



Mini microwave TU0049

Small microwave with lighting and sound. This interactive toy is a perfect addition to any children's kitchen. It is simple to use, all children need to do is open the door, put the chicken inside and use the switch to make the food spin and change colour while cooking.

- material: plastic; powering: 3 x AA batteries;
dim. of the packaging: 27 x 13 x 18,5 cm;
age: 3+





**Fruits and vegetables
in wooden boxes. Classroom set
VG4523**

Vegetables and fruits made of wood painted with good quality paint. Their fun look encourages children to play.

They work well as toys or teaching aids in learning how to count, sort or name colours. Each box contains 7 fruits or vegetables, such as: pears, apples, garlic or aubergines.

- dim.: 19,7 x 14,4 x 5,4 cm; age: 3+



**Garden Grill
TU0060**

Grill set. Perfect for developing creativity and for playtime involving roleplay. This set also helps children to learn how to systemise their actions. The set includes kitchen tools such as a spatula, a meat fork, a plate, a ketchup, cooking tongs and bbq food.



**Jumbo. Set of play dishes
JN0510**

Set of 86 elements including: a tea set, a dinner set, a cooking and baking set, cutlery, cups and plates. A dish dra-

iner and a tray make sorting the elements easier. All elements are made of BPA-FREE plastic and because of it, they are safe for food storage, and they will provide years of fun.



BEAUTY

**Mini wooden dressing table
CI0543**

It is made of wood and painted with subtle colours. The set includes a comb, a lipstick, a straightener, a bracelet, a ring, a makeup brush, a powder-box. This dressing table with accessories is perfect for playtime involving roleplay and it can boost children's creativity.

- dim.: 17 x 23 x 35,6 cm; age: 3+



DOLLS CORNER



2in1 cradle C10547

A 2 in1 doll's bed which can be transformed into a cradle. It is made of wood and a durable material. After turning the cradle, it becomes a crib.

- dim.: 43,8 x 29,7 x 22 cm; age: 3+



Wooden doll pram C10549

A doll pram with a wooden frame.

- dim.: 43,2 x 32,5 x 50,5 cm; age: 3+



Baby at the doctor's office TU0058

Doll with medical accessories. Playtime with this doll teaches children empathy and responsibility. The set includes: a stethoscope, a syringe, a thermometer, a medicine box, two ampoules of medicine and bandages.

- age: 3+



Baby in the bath TU0052

Doll with a bath, a towel, and a bottle. The doll is dressed in a bathrobe. The doll's height: 16 cm.

- age: 3+



Nurse doll TU0053

Doll with accessories – Nurse. The set includes: a stethoscope, a microscope, a mask, a syringe and a nurse's briefcase. The doll is dressed in a nurse uniform.



GARAGE CORNER

Two-story garage with a lift C13658

Colourful, two-story garage with a transparent lift, two cars and a helicopter. It boosts children's creativity through its various elements, such as: a lift, vehicles, a car wash or a gas pump. This set is perfect for developing the narrative skills.

- dim.: 62 x 30 x 37 cm; age: 3+



PETS

Vet. Wooden house with accessories

VG4558

Set of 19 elements stored in a suitcase which makes transporting and storing the folding house much easier. Playtime with the house teaches children empa-

thy towards animals, it helps them to develop their imagination and social skills. The set includes: a dog, a vet, a nurse, a cat, food for animals, toys for animals and medical instruments. It is mainly made of wood.

- dim.: 22,5 x 12,2 x 16,8 cm; age: 3+



DOCTOR'S AREA

Wooden doctor's kit C14419

This set of 19 elements is mainly made of wood and it contains a stethoscope,

a syringe, a thermometer, a patient card and tweezers.

- dim.: 22,5 x 17 x 8 cm; age: 3+



Beauty salon for pets

TU0057

Set of 22 elements, including: a hairdryer, a shampoo, a hairbrush and scissors. All elements are made of durable plastic. Perfect for games involving roleplay, boosting creativity and learning the meaning of responsibility.

- dim.: 37 x 20,5 x 54,5 cm; age: 3+



TEDDY BEARS



Ben
NS2657

Soft teddy bear Ben dressed in a white shirt, perfect companion during play or relaxation time.

- dim.: bear in a sitting position – 23 cm; it has got plastic eyes



Hugo
NS2658

Teddy bear Hugo dressed in a graduation gown. This smart bear is a great companion of children's games.

- dim.: bear in a sitting position – 23 cm; it has got plastic eyes



Bobi
NS2659

Big light brown teddy bear Bobi with plastic eyes. It is dressed in a white shirt.

- dim.: bear in a sitting position – 30 cm



Luke
NS2660

Big dark brown teddy bear Luke with plastic eyes. It is dressed in a white shirt.

- dim.: bear in a sitting position – 30 cm



ANIMAL MODELS



Rodents. Animal figurines

MJ0010

Hand-painted rodent figurines made of safe and durable plastic. The replicas faithfully reflect the anatomical details of the animals, and they look natural. This set will not only be a great addition to a collection of figurines, but it

will also help to boost the children's creativity and imagination.

- 6 pcs.: a badger, dim.: 7 x 2,5 x 3 cm;
- a beaver, dim.: 8,5 x 3 x 3 cm;
- a hedgehog, dim.: 4,5 x 3 x 2,5 cm;
- a mouse, dim.: 6,5 x 3 x 2,7 cm;
- an otter, dim.: 9,5 x 2 x 3 cm;
- a squirrel: dim.: 4 x 1,5 x 5 cm;
- material: plastic; age: 3+

PLASTIC TOYS



Dustbin lorry with lights and sound

TU0051

- dim.: 18 x 10 x 11 cm; material: plastic; age: 3+



Digger with lights and sound

TU0054

- dim.: 20,5 x 10,3 x 16 cm; age: 3+



Cement mixer with lights and sound

TU0056

- dim.: 19 x 10,5 x 15 cm; age: 3+



Tipper lorry with lights and sound

TU0055

- dim.: 18 x 13 x 10 cm; age: 3+



Transport plane with a mechanic

TU0059

An aeroplane which can be used for the transport of 5 engineering vehicles, such as a digger, a dozer, a tipper lorry, a dustbin lorry and an oil tanker, included in the set. It also provides parking space for them. A figurine of a mechanic is also included in the set.



MOTOR SKILLS

CONSTRUCTION

BRICKS & WORKSHEETS



Transparent gears
AP2559

The set consists of transparent elements. It has special holes in which gears are placed. Gears placed on the board engage, and by rotating them in both directions, they set other elements in motion. This set can be used on any flat surface, or it can be combined with the illuminated panel for an additional visual effect. The toy improves eye-hand coordination, trains fine motor skills and strengthens the tweezers grip.

- 9 pcs.: 1 x base dim.: 30,8 x 6 x 30,8 cm; 4 x big gears, 4 x small gears; material: plastic; age: 3+



Maxi plastic ball tracker
NS4113

This set allows children to boost their creativity by building tracks for balls.

- the set consists of 89 elements, including: 5 coloured balls, 60 simple construction bricks, 4 half-rounded construction bricks, 1 slalom-shaped construction brick, 2 bases, 2 funnels, 1 brick with a spinning wheel, 3 diagonal bridges, 8 snail-shaped bricks, 1 big funnel, 1 catapult



construction bricks for presented worksheets are available in export catalogue 2021



Worksheets for multibricks with connecting elements
NS3585W

- Set of 24 worksheets for multibricks with connecting elements (NS4095+V03583), dim. of a single piece: 11,5 x 11,5 cm; the combination ideas vary in their level of difficulty; all worksheets can be easily stored thanks to the box included in the set; age: 3+



Worksheets for rounded transparent bricks
JN0040W

- set of 24 worksheets for rounded transparent bricks with connecting elements (JN0040W), dim. of a single piece: 11,5 x 11,5 cm; the combination ideas vary in their level of difficulty; all worksheets can be easily stored thanks to the box included in the set; age: 3+



Worksheets for transparent bricks with a board
JN0111W

- set of 24 worksheets for transparent bricks with a board (JN0111), dim. of a single piece: 11,5 x 11,5 cm; the combination ideas vary in their level of difficulty; all worksheets can be easily stored thanks to the box included in the set; age: 3+



Worksheets for Gears

NS4102W

- set of 24 worksheets for construction bricks - gears (NS4102W), dim. of a single piece: 11,5 x 11,5 cm; the combination ideas vary in their level of difficulty; all worksheets can be easily stored thanks to the box included in the set; age: 3+



Worksheets for Caterpillar

NS4108W

- set of 24 worksheets for construction bricks - caterpillar (NS4108W), dim. of a single piece: 11,5 x 11,5 cm; the combination ideas vary in their level of difficulty; all worksheets can be easily stored thanks to the box included in the set; age: 3+



Worksheets for Vehicles

NS4101W

- set of 24 worksheets for mobile construction bricks - vehicles (NS4101W), dim. of a single piece: 11,5 x 11,5 cm; the combination ideas vary in their level of difficulty; all worksheets can be easily stored thanks to the box included in the set; age: 3+

 construction bricks for presented worksheets are available in export catalogue 2021



Worksheets for transparent nails with a board

JN0110W

- set of 24 worksheets for transparent nails with a board (JN0110W), dim. of a single piece: 11,5 x 11,5 cm; the combination ideas vary in their level of difficulty; all worksheets can be easily stored thanks to the box included in the set; age: 3+



construction bricks for
presented worksheets
are available in export
catalogue 2021

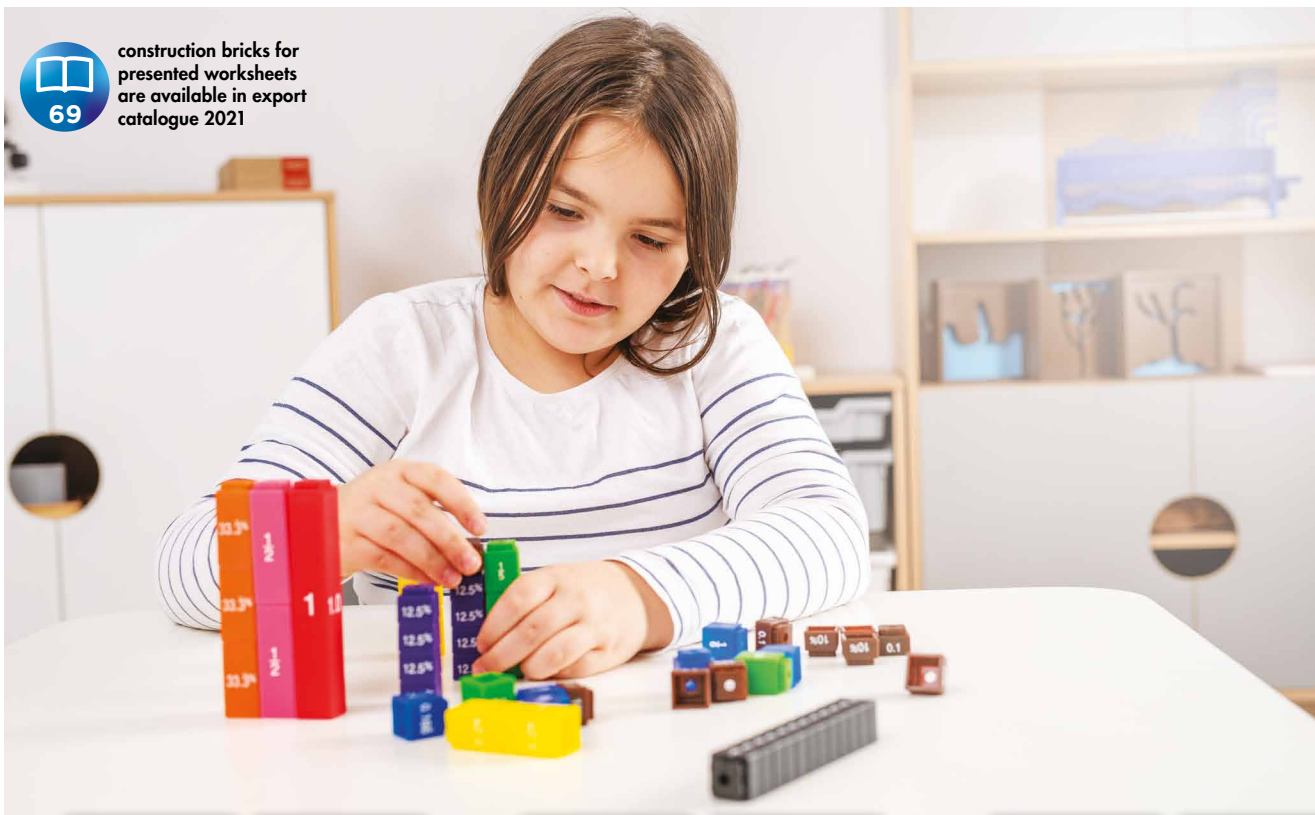

Worksheets for transparent tubes
JN0036W

- set of 24 worksheets for construction bricks – transparent tubes (JN0036W), dim. of a single piece: 11,5 x 11,5 cm; the combination ideas vary in their level of difficulty; all worksheets can be easily stored thanks to the box included in the set; age: 3+



Worksheets for Equivalency cubes set
JN0041W

- set of 24 worksheets for the Equivalency cubes set (JN0041W), dim. of a single piece: 11,5 x 11,5 cm; the combination ideas vary in their level of difficulty; all worksheets can be easily stored thanks to the box included in the set; age: 3+



Worksheets for transparent windows
for creating geometric solids
JN0048W

- set of 24 worksheets for transparent bricks for Creating geometric solids - windows (JN0048W), dim. of a single piece: 11,5 x 11,5 cm; the combination ideas vary in their level of difficulty; all worksheets can be easily stored thanks to the box included in the set; age: 3+

HAND-EYE COORDINATION



Eight track. Concentration training WP0019

Eight is equipped with handles on the sides to facilitate the manipulation of the toy. It's raised sides prevent the ball from falling off the track. This toy develops manual skills, improves eye-hand coordination but also concentration. It activates and integrates both cerebral hemispheres and improves binocular vision.

- dim. of the product: 34 x 5 x 22 cm; ball included in the set; material: plastic; age: 3+



Big magnifying glass with kaleidoscope glasses JN0260

Set of durable magnifying glasses to discover the world in a new perspective. High quality lenses with a kaleidoscopic effect ensure great visual sensations. They are equipped with big handles suitable for little hands or people with disabilities.

- 6 pcs.; frame in 6 colours; age: 18 months +



Big magnifying glasses JN0028

Big magnifying glasses for examining and observing animals, plants and objects under magnification. High quality lenses also help children to learn about colours.

- 6 pcs.; frame in 6 colours; in a cardboard box; age: 18 months +





Transparent butterflies

JN0088

Transparent insects help children to study the properties of colour and light. It is a great aid in developing the ability to count, sort and create sequences. When combined with the illuminated panel, they provide amazing visual sensations. The set is delivered in a plastic box.

- 120 pcs., 4 types of insects: ladybug, bee, dragonfly, butterfly; 6 colours; dim. of the packaging: 16 x 6 x 16 cm; age: 3+

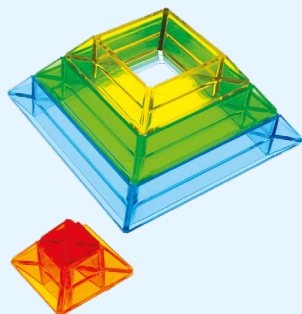

Transparent diamond

JN0055

Set of transparent frames allows children to arrange or combine elements from which 3D structures, related to each other by size, can be created. Shapes in 5 sizes are also perfect for experiments with colours when combined with the illuminated panel. This set develops motor skills, spatial imagination, eye-hand coordination and the ability to think logically.

- 30 pcs., dim. of the biggest frame: 10 x 10 cm; material: plastic; age: 3+



Transparent bears with accessories for sorting

JN0105

Set for learning how to sort and count. It contains bears in 3 sizes, tweezers and bowls. This is a great aid for learning how to recognise the colours, how to match elements; it develops math skills and eye-hand coordination. The set is also perfect for stimulating imagination, encour-

aging creative thinking and improving manual skills. Rich colour palette and a significant number of elements guarantees hours of great fun. Colourful bears with accessories ensure pleasant experiences during occupational therapy or therapy for children with special educational needs. The set is delivered in a plastic box.

- 80 pcs.: 72 bears in 3 sizes; 6 bowls, 2 tweezers; 6 colours; material: plastic; dim. of the packaging: 16 x 16 x 12 cm; age: 3+



Magnetic cube with worksheets

UT0032

Transparent magnetic bricks which allow children to build various spatial constructions based on instruction with pictures or their own ideas. Combining the bricks is very simple thanks to the built-in magnets. Playtime with the set is not only fun, but it also promotes

harmonious development of the child. These bricks improve the ability to solve spatial problems, they also stimulate creativity and analytical skills. Additionally, the set develops motor skills and stimulates the senses.

- 7 pcs.; in different configurations, dim.: cubes when folded: 6 x 6 x 6 cm; instruction; material: plastic, magnet; age: 3+

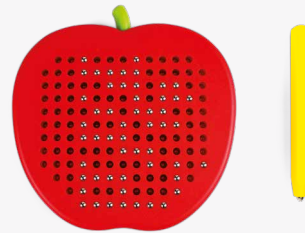

Magnetic apple with worksheets

UT0036

Magnetic puzzle in the shape of an apple. Metal balls are placed in holes on the board. The magnetic stylus makes the balls move to the surface of the tablet and it is possible to create patterns, letters or numbers. Each composition can be easily erased with fingers by pressing the balls

into the centre of the board. This toy stimulates creativity, imagination and it develops motor skills. The puzzle is also a great aid in learning to count or to write letters and numbers. The set includes worksheets which allow children to familiarise themselves with a new technique of "painting".

- 1x board with metal balls,
- dim.: 12,3 x 2,4 x 12 cm, 1 stylus, worksheets; age: 3+





Tetris. Wooden puzzle

UT0040

Wooden puzzle containing four games: Tetris, Tangram, Huarong Road

and mushroom puzzle. All elements of the set can be easily placed on the board or taken off of it.

- dim.: 27 x 18 x 1,5 cm; age: 3+

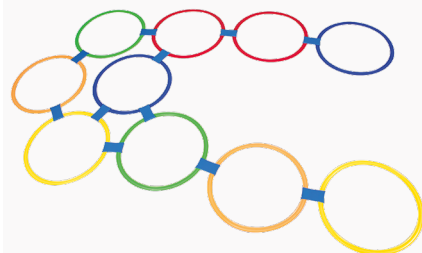

Coloured hoops.

Dexterity game

UT0041

This game helps to develop motor coordination and creativity. Rings can be freely combined with each other to provide lots of fun.

- dim.: 29 x 29 x 7 cm



Magnetic fish puzzle

EO2181

Magnetic puzzle game – fish and a rod. Players can put the fish on the board or pick them up.

- dim.: 22 x 26 x 1,2 cm; age: 3+



Magnetic fish. Table

VG4546

Table for little fisherman with magnetic fish and fishing rods included in the set. This toy guarantees many hours of great fun which at the same time develops manual skills, dexterity and eye-hand coordination. On the backs of all the fish numbers from 1 to 10 are placed to facilitate learning to count and to associate numbers with quantity.

- dim. of the table: diam.: 45 cm, height: 11 cm; elements: 1 table, 4 fishing rods, 40 fish in four colours; material: wood, magnet, fitting elements: 4 x screws; age: 2+



Catch and Sort. Dexterity game VG4574

Puzzle developing manual skills, dexterity, eye-hand coordination and logical thinking. It also trains patience, precision of hand movements as well as stimulates imagination. This toy contains wooden balls, which should be moved to the base with holes using sticks, spoons or tweezers in order to create colourful

patterns. First, children have to fish out the ball they need from the rest, position it properly in their fingers and then throw the ball in the hole on the board. Mosaics can be arranged based on the suggestions from the worksheets or children's ideas. The entire set is kept in a box with compartments.

- 94 pcs.: 80 balls in 8 colours, 1 spoon, pair of sticks, 1 tweezer, 10 worksheets with patterns; material: wood; age: 3+



Rabbit box. Topology worksheets UT0037

Fantastic logic game which includes 3 wooden bricks, a bunny and a set of activity cards with varying degrees of difficulty. The children's task is to arrange the elements of the set in such a way as to obtain the pattern presented on the card. This game introduces children to

the concepts of: higher/lower, up/down, outside/inside, visible/hidden, etc. It also teaches about colours, shapes and depth perception as well as develops manual skills, eye-hand coordination, imagination and logical thinking.

- dim.: of the box: 9,5 x 9,5 x 9,5 cm; dim. of the yellow and red element: 7,5 x 3,5 x 7,5 cm; dim. of the bunny: 4,5 x 11 cm; 60 activity cards, dim.: 9 x 9 cm; instruction; age: 3+



Pin art board. Educational aid HG0069

Creative mosaic made of safe pins. They allow children to make an imprint of whatever they want in the form of 3D reflection. This toy is suitable for younger and older children, and it guarantees many hours of great fun. It develops creativity, imagination, spatial perception as well as stimulates the senses.

- dim.: 12,5 x 5,5 x 9,5 cm; material: plastic; colour chosen at random; age: 3+



Toddler's ball TU0050

- 1 pc.; dim.: 11 x 11 x 11 cm; material: plastic; age: 1+



MATH



Transparent fractions circle on a spindle. Classroom kit JN0200

- semi-transparent fractions from $\frac{1}{20}$ to 1; when combined, they form a full circle; they can be put one on top of the other so that children can build a fraction tower; perfect for learning fractions; the full circle has got a diameter of 10 cm; age: 3+

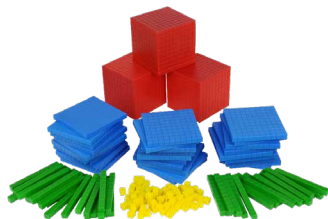

Decimal system. Classroom kit JN0051

- set of 183 elements including 3 red cubes, 30 blue squares, 50 green sticks and 100 yellow units; age: 3+



Transparent maths cubes JN0021

- dices made of a durable semi-transparent plastic; perfect for learning to count, sort and create patterns; dim.: 2 cm; age: 3+



Maxi maths kit of transparent counting sticks JN1060

- the set includes: 78 squares with letters, 72 crystals, 72 rings, 36 geometric beads, 36 geometric shapes, 10 numbers and 6 boards; perfect for learning colours, shapes, numbers, sorting and mathematics; age: 3+

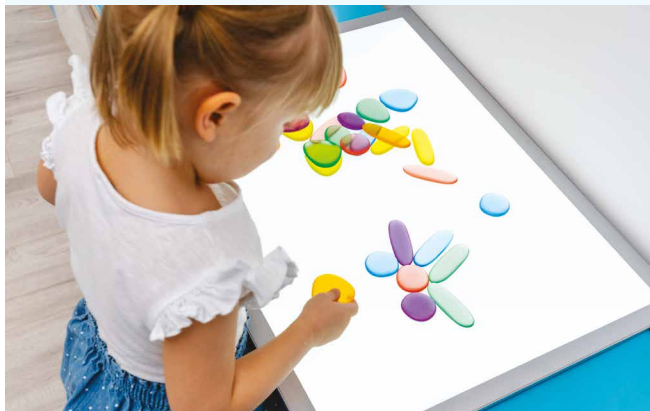

SCIENCE

PHYSICS



HG0077 available in export catalogue 2020



Hand vacuum pump HG0078

A hand pump equipped with two nozzles. One of them is used to pump out the air to create a vacuum, while the other nozzle generates overpressure, which will allow air to be pumped into, for

example, a balloon. Connection with HG0077 Vacuum bell jar.

- the inner diam. of the cylinder 2,25 cm; length: 20 cm, nozzles: outer diam.: 0,9 cm; hand grip: diam.: 2,8 cm, length: 10 cm; material: steel, plastic, wood; max. pressure: $\leq 6,7 \times 103$ Pa (500 mmHg), min. pressure: $2,9 \times 105$ Pa (3 kgf/cm²); hose: 30 cm long

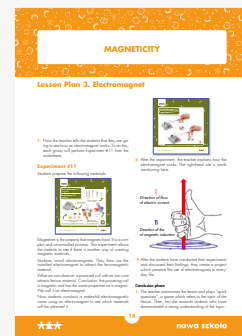
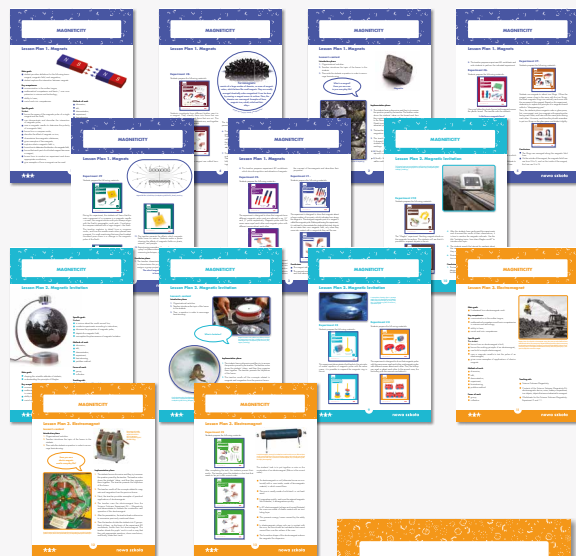

more science suitcases
available in export
catalogue 2021



Magnetism. Science suitcase with lesson scenarios and worksheets NS6119

The contents of the suitcase allow students to conduct simple experiments in the field of magnetism. With this set, it is possible to build electromagnets, test magnetic properties of different materials or to demonstrate how ma-

gnets and magnetic fields work. The teacher can also prepare an experiment which shows magnetic levitation. The lessons scenarios included in the set contain goals, methods, forms and a detailed lesson plan involving various interesting activities. The worksheets make conducting the experiments much easier thanks to the clear instructions.

DALTON'S PLAN

Dalton teaching aids help to enable the implementation of The Dalton Plan pedagogical education technique. Instead of the traditional classroom model, learning takes place through experience and action. The focus is on the individual work of students while the teacher's role is to guide students and meet their various educational needs. The Dalton Plan allows the teacher to adjust the pace of learning to real predispositions of children. It teaches them to rely on themselves, to take action and to think independently. Children develop a sense of responsibility and they are motivated to search for the best and simplest work strategies. When creating the teaching aids for the Dalton Plan technique, the visual aspect is crucial. The visualisation is extremely valuable and effective.



Magnetic Week Planner. Tulips. Dalton Plan.

NS9611

Magnetic board with colourful days of the week in the shape of tulips. It helps children to get acquainted with the concept of the days of the week. Tulips'

colours are unique and they symbolise different days. The attached arrow serves as a pointer. By using it, children can easily mark a given day of the week. Perfect educational aid for the implementation of the Dalton Plan.

- dimensions of the board: 74cm x 14cm



Clock. Dalton Plan

NS9600

The clock has a visible clock hand and a dial face with time intervals and corresponding colours. This division is clear, and it makes the clock perfectly suited for use in preschools and schools. It helps to understand the concept of time, the rules of determining it and to plan the work in a given period. Before children start their individual work, the teacher should

specify which colour represents the time they have to complete the task. The hand of the clock should be set manually.

- dim.: dim. of the dial: 43 cm; time intervals and colours: red – 5 minutes, green – 10 minutes, blue – 15 minutes, yellow – 30 minutes; material: MDF boards, 10 mm thick; battery powered mechanism: 1,5 V AA; age: 3+

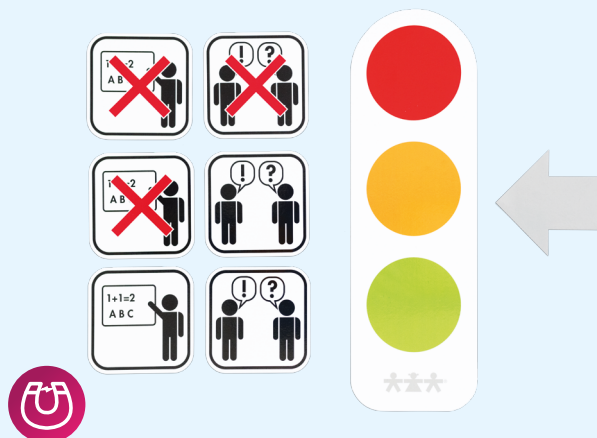

Magnetic traffic lights.

Dalton Plan

NS9603

Magnetic traffic lights help the teacher in non-verbal communication with children. By using the method of deferred attention, we give children a chance to work individually at their own pace. Only three colours are used to instruct the children.

- Red colour - independent work, time to think abo-

ut a solution.

- Yellow colour – children who didn't find a solution can ask their friends for help.
- Green colour – children who still didn't find the solution can ask their teacher or a classmate for help.
- In most cases, children are able to solve the assigned tasks alone or with the help of a friend. It teaches them to rely on themselves, to think independently and they are motivated to find the best and simplest solutions.
- dim.: 38 x 12 cm, dim. of the pictograph: 10 x 10 cm, dim. of the arrow: 10 x 10 cm

SAFETY ON THE ROAD



Reflective vest for toddlers
NS2090

The vest can be put on by pulling it over the head. Thanks to the elastic bands on the sides, putting it on is easy and the vest fits better. Side slits provide air circulation when it's hot outside, and when it's cold, they stretch to make room for a thick, warm jacket.

- 1 pc., dim.: 37 x 43 cm; fabric: polyester

MUSIC WOODEN INSTRUMENTS

Toucan. Music kit
C14032

This set for beginning musicians contains: xylophone, tambourine, castanets. It is a great aid in developing sensitivity, hearing and sense of rhythm. Thanks to it children can learn to recognise various sounds. All instruments are suitable for young users.

- 7 pcs.: 1 x xylophone, 1 x flute, 1 x tambourine, 2 x castanets, 2 x drumsticks; material: wood, metal; dim. of the packaging: 40 x 6,5 x 30 cm; age: 18 months +





**Small bag with
music instruments**
NT0149

Musical set of 5 instruments. It helps to develop musical abilities and motor skills.

- age: 1+

Big and colourful rumba shakers.
Classroom kit

NT2111

Set of simple colourful rumba shakers. The shape of an egg makes them easy to use. Their clear sound can be combined with other instruments. Perfect for stimulating the sense of hearing. They can also be used as a percussion instrument. The product is made of safe and BPA-free material, lead and phthalates.

- 12 pcs. in 6 colours: 2 x white, 2 x yellow, 2 x red, 2 x green, 2 x blue, 2 x purple; dim.: diam.: 4,5 cm, height: 6,5 cm; material: plastic; age: 0+



THEATRE

COSTUMES



Frog cap and gloves

KK0080

The set consist of a cap made of velour-like fabric with sewn-in elastic band and covers for hands.



Grizzly bear cap

KK6870

A cap made of nice to touch fabric with sewn-in elastic band.

MUSICAL BALLS



Sound balls with notes of music

NT3500

Sound-making rubber balls with musical notes.

- 8 pcs, dim.: 6,1 x 6,1 x 6,1 cm



ARTS & CRAFTS

CLASSROOM SET

Therapy through art allows the use of many different forms of artistic expressions. By sculpture, painting, drawing, singing, playing instruments the therapist can address the patient's feelings, emotions, needs and fears. This form of therapy is suitable for everyone, regardless of age, and it can equally serve children, adults and the elderly. The patients are not required to have any artistic skills as the creative process itself has a therapeutic effect. In order to facilitate the implementation of art therapy, we present a wide selection of inspiring products such as, sets of high-quality crayons, dry pastels, paints, decorative cardboards and drawing papers as well as origami and quilling tools. We also offer a large variety of musical instruments from tambourines, flutes, maracas, castanets to bells which

can introduce the elderly to the world of sounds. Through different techniques, fine art therapy helps patients to discovering and developing their talents, skills or predispositions. Thanks to this, it supports the therapeutic process as well as personal development. With a view to provide the elderly with all the equipment they may need to be artistically fulfilled, we prepared a special offer of creative art materials. Among them can be found well selected products intended for those who want to learn to paint or draw as well as colourful materials dedicated to creating decorations and ornaments. We offer all kinds of punches, modelling pastes, crepe papers and paint pens for porcelain. For scrapbooking, decoupage, quilling or origami, we provide professional tools and accessories.



Senior art starter kit

TM2006

Rich set of art supplies for the realisation of creative projects. This set allows teachers or therapists to prepare interesting art classes. Thanks to such activities it is possible to develop unique ideas and creativity, while maintaining good manual dexterity.

The set contains:

- 1 x Set of papers,
- 2 x White A4 drawing paper,
- 1 x 11 Tempera paints in 6 colours,
- 1 x 11 Tempera paint in black,
- 1 x Ceramic paints,
- 1 x Oil pastels. Set,
- 1 x Stained glass paints,
- 1 x Origami triangle,
- 1 x Origami square,
- 1 x Small origami circles,
- 1 x Set of 60 pcs. long thin colour pencils,
- 1 x 11 Universal glue,
- 1 x Set of 12 professional flat brushes,
- 1 x Set of 12 professional round brushes,
- 1 x Plaster,
- 1 x Coloured pompons,
- 1 x Set of feathers,
- 1 x Sequins in a case,
- 1 x Quilling set for the whole year,
- 1 x Water containers for paints,
- 1 x Paint pallets,
- 1 x Scissors,
- 1 x Ceramic pots for decoration,
- 1 x Vases for decoration,
- 1 x Crepe paper – mix.



Nursery art starter kit

TM2004

Set of art supplies for toddlers necessary for the realisation of their creative projects. This set allows teachers to prepare interesting classes using various art techniques.

The set contains:

- 1 x A4 xero coloured paper,
- 1 x A3 drawing paper, 100 pcs.;
- 1 x A4 coloured cardboard;
- 1 x Coloured cardboard. Dots and lines;
- 1 x Classroom set of thick crayons, 60 pcs.;
- 1 x A4 coloured metallic corrugated cardboard,
- 1 x Origami paper – animals,
- 1 x Crepe paper – mix, 10 pcs.;
- 1 x Aiko eco paints, 6 x 0,5 l paint;
- 1 x Finger paints, 6 x 100 ml;
- 1 x Water container for paints, 6 pcs.;
- 1 x Animal texture stamps, 4 pcs.;
- 2 x Paint stand;
- 1 x Texture stamps, 6 pcs.;
- 2 x Barrel brushes for toddlers, 5 pcs.;
- 1 x Classroom set of play-doh, 180 pcs.;
- 1 x Modelling clay in cubes, 12 pcs.;
- 1 x Craft glue, 1000 ml;



Afterschool club art starter kit

TM2005

Set of supplies necessary for the realisation of art projects at the after-school clubs. This set allows children to discover various art techniques.

The set contains:

- 1 x A4 xero coloured paper;
- 1 x A3 drawing papers, 100 pcs.;
- 1 x A4 coloured cardboard;
- 4 x Triangle colour pencils, 12 pcs.;
- 1 x Classroom set of crayons;
- 1 x Aiko eco paints, 6 x 0,5 paint;
- 4 x Paint palettes;
- 1 x 9 mm Standard flat brushes, 8 pcs.;
- 1 x 8 mm Standard flat brushes, 8 pcs.;
- 4 x 35 g Glue sticks,
- 1 x Classroom set – play-doh, 180 pcs.;
- 1 x Universal glue, 1l;
- 2 x Crepe paper – mix;
- 1 x Coloured creative wires, 100 pcs.;
- 1 x Stained glass paper;
- 1 x Feathers, 150 pcs.;
- 1 x Coloured pompons, 100 pcs.;
- 1 x Eyes, 560 pcs.;

PAINTS

Tempera paint to be used without adding water. It was made of high-quality pigments which guarantee light resistance and colour intensity. The paint washes off easily. It can be freely mixed with other colours.

11



Turquoise tempera paint
RL0757



Fuchsia tempera paint
RL0755



Pink tempera paint
RL0756

0,5 l



Nude tempera paint
RL1758



Black tempera paint
RL1100

BRUSHES



Sensory brushes with big handles **AP2335**

Set of stamps and brushes which help to develop creative thinking and motor skills. All supplies are equipped with a comfortable stamp. Stamps can be

used with paints or modelling clay. They are made of durable plastic that can be reused.

- 6 pcs.: 3 stamps (small dots, parallel lines, large studs), 3 brushes (short and round, wide and flat, long and round); dim. of the product: 16 x 4 x 12 cm; age: 3+

STENCILS



Mandala template **AP2537**

Set of templates for drawing mandala. Perfect for use with paints, crayons and felt tip pens. In order to use it, place the template on a flat surface and trace

the pattern. These reusable templates are made of white durable plastic and they are easy to clean. They are also perfect for developing creativity and eye-hand coordination.

- 6 pcs.; dim.: 15 x 15 cm; material: plastic; age: 3+

DECORATION



Eyes stickers

AP2528

Colourful stickers in the form of eyes in several designs. These stickers are perfect for the realisation of art projects. They can be used to decorate handmade dolls, greeting cards or other art works as it is possible to stick them to different surfaces: paper, wooden spoons, polystyrene shapes.

- 240 cardboard stickers; diam. of the eye: 1,2-1,7 cm;
- dim.: of the sheet: 15 x 22 cm;
- age: 3+



Felt flowers

AP2464

- set of 100 felt flowers for decoration



Cotton string

AP0002

- 200 m long cotton string



Self-adhesive eyes

AP1001

Self-adhesive eyes of different designs and sizes. Perfect for decoration and creative art projects.



Decorative lampshades.

Classroom kit

AP2540

Paper lantern with a diam. of 20 cm. Perfect aid during art classes. Lanterns can be decorated with paints, fibre-tip pens, stickers, glitter, etc. They are delivered in a flat packaging with metal frame.



Styrofoam hearts.

Classroom kit

AP2524

Styrofoam hearts to decorate with various art techniques. They can be used as a base for different souvenirs or headresses. The set of 20 hearts.

- dim.: 4 x 2 cm



**Styrofoam stars.
Classroom kit**

AP2526

Styrofoam stars to decorate with various art techniques. They can be used as a base for different souvenirs or headaddresses. The set of 20 stars.

- dim.: 6 x 2,4 cm



**Styrofoam Christmas trees.
Classroom kit**

AP2527

Styrofoam Christmas trees to decorate with various art techniques. They can be used as a base for different souvenirs or headaddresses. The set of 20 Christmas trees.

- dim.: 7,5 x 2,7 cm

ACCESSORIES



Coloured pot with a handle

JN0015

Plastic pot which helps to keep order. It can be used as a box on the shelf, on the rack or in the drawer. Delivered with a description label for the content.

- 1 pc.; dim.: 11,8 x 10,5 x 7,6 cm; material: plastic



Paint pots for stamping

AP2535

Coloured paint pots for creating paintings with dots or for filling bigger spaces. Their unique design with a comfortable ball-shaped handle makes them easy to use and suitable for toddlers. Perfect addition to any creative activity with stamps. They can be stored in a cardboard box with a tray. The set allows a group of children to play together.

- 24 pcs.; colours: red, yellow, blue, green, orange, purple; material: plastic; age: 3+



Connecting pots

AP2533

Practical pots for storing art and writing supplies. They can also serve as water cups while painting with paints or they can be used to as an organiser for crayons or felt tip pens when combined. These containers make it easier to keep order and they don't take up too much space.

- 8 pots: yellow, orange, red, blue, purple, green, white, black; dim.: 11 x 10 cm; material: plastic; age: 3+



Craft trays

JN0094

Colourful rectangle trays for sorting counting stick or other small objects. They are equipped with



comfortable handles. Raised sides of the trays prevent the contents from falling off the tray.

- 4 pcs.; dim.: 38,5 x 2 x 28,5 cm; colour: green, red, yellow, blue; material: plastic



Glue spatulas

AP0405

Glue spatulas suitable for every kind of glue. They are equipped with an elastic tip which makes using the spatulas easier. This product helps to keep the working space clean.

- set of 12 spatulas; material: durable plastic; length: 11,3 cm



furniture

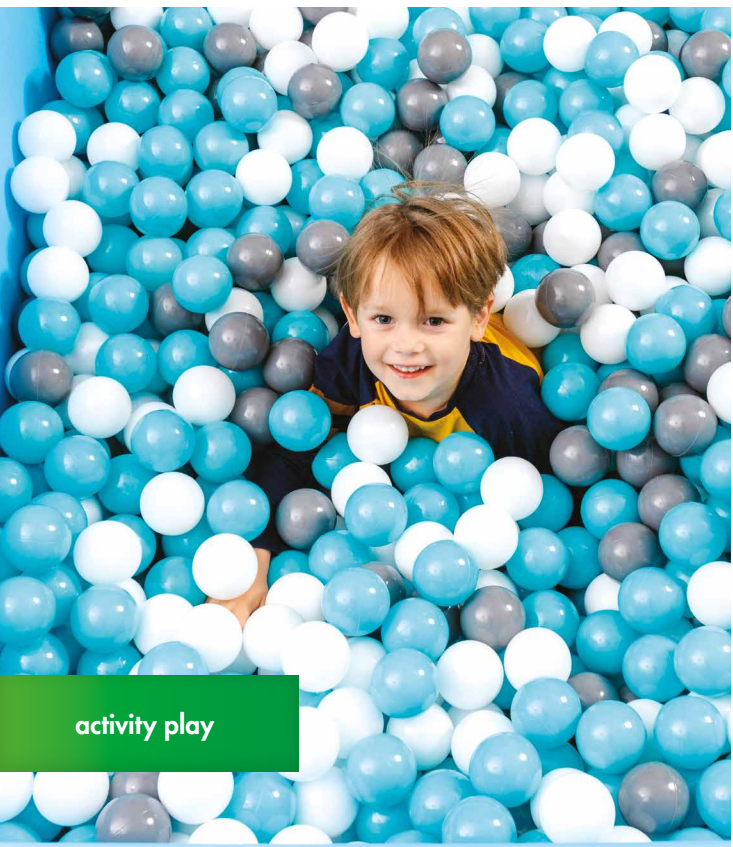

activity play

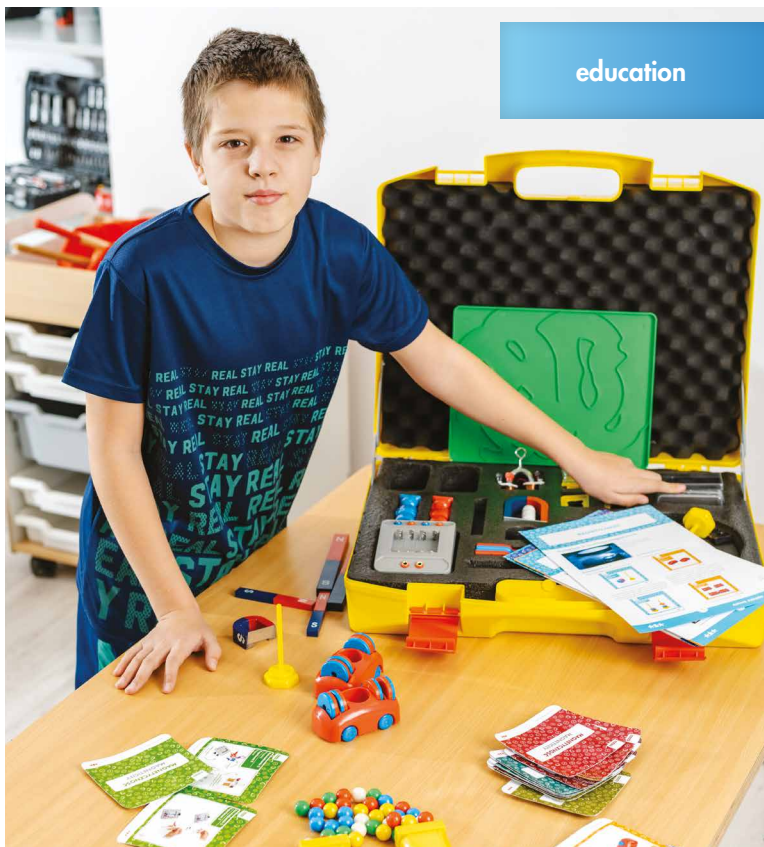

education



POW 25
90248 Lodz, Poland



+48 42 639 97 37



www.nowaszkoła.com



export@nowaszkoła.com