



i n t e r n a t i o n a l

2023

EDUCACIÓN

nowa szkoła

EDUCATION

MOTOR SKILLS TODDLER FENCES FARMYARD



Farmyard panels CI8000

This set of fence panels featuring various activities creates a wonderful playcorner. The elements include mazes, cogs, mirrors, beads. Practical connectors ensure stability and safety. The decorative elements (animal heads) can be connected freely with the fencing. All the elements are made of plywood.

- 7 panels, 7 connectors (including 1 corner one), 5 animal heads, 1 gate;
- 20 elements in total;
- corner size: 330 x 345 cm

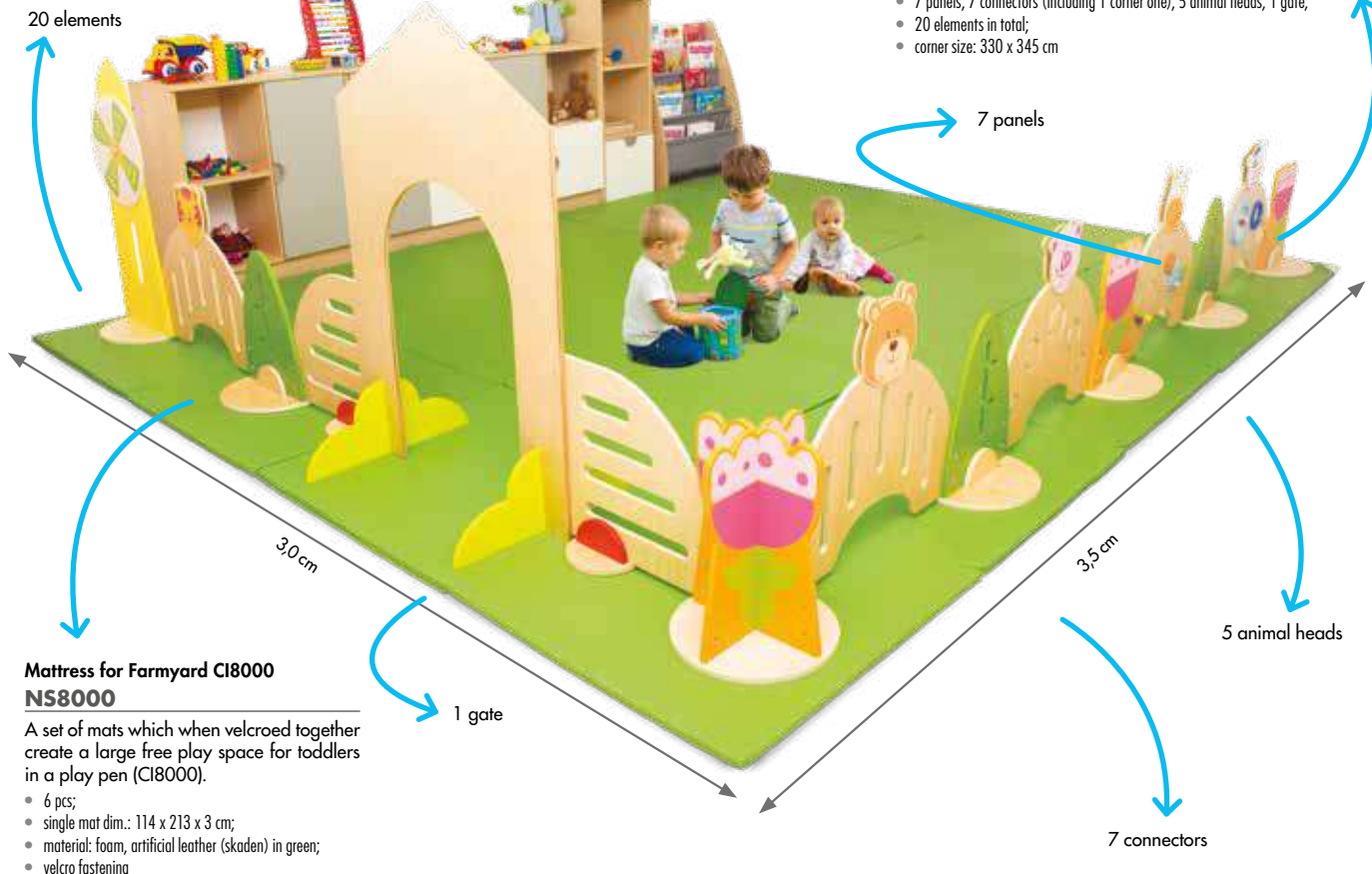

Mattress for Farmyard CI8000 NS8000

A set of mats which when velcroed together create a large free play space for toddlers in a play pen (CI8000).

- 6 pcs;
- single mat dim.: 114 x 213 x 3 cm;
- material: foam, artificial leather (skaden) in green;
- velcro fastening

VILLAGE

Square NS2133

A multi-element wooden play fence with a gate and various decorative panels (including a maze, a manipulative border, safe acrylic mirrors and a revolving wheel). The panels are joined with push-in connectors. The panels and connectors are made of MDF.

- 16 panels, each H 60 - 80 cm, W 80 cm



Corner NS2131

A multi-element corner wooden play fence with a gate and various decorative panels (including a maze, a manipulative border, safe acrylic mirrors and a revolving wheel). The panels are joined with push-in connectors. The panels and connectors are made of MDF.

- 8 panels, each H 60 - 80 cm, W 80 cm

Mattresses for toddler fencing NS2132

Three folding mattresses, each made up of three squares. Together they create a large playing area of max 9 elements (300 x 300 cm in area).

- strong velcros prevent accidental slides;
- each mattress when unfolded 300 x 100 cm, when folded 100 x 100 cm



MANIPULATIVE SCREENS

Space arrangement for children at nursery age is a real challenge. The attention to its safety, functionality, attractiveness and aesthetics should be a priority in designing a place for the youngest. Our line of manipulative partitions meets all of the above requirements. The construction enables unrestricted and artistic arrangement of kids' corners, its visual side changes every play-space into a happy realm great for all children. The screens, designed with the youngest in mind, help improve abilities of small motoricity, engage visual perception and improve sight-movement coordination. The item is made of varnished plywood.

- it consists of: manipulative tapestry with a horse;
- safe, moving mirrors;
- 3D mazes;
- Zig-Zag maze for graphic activities and a gate with colourful flag



Window
NS0090

- size: 81 x 63 x 22 cm

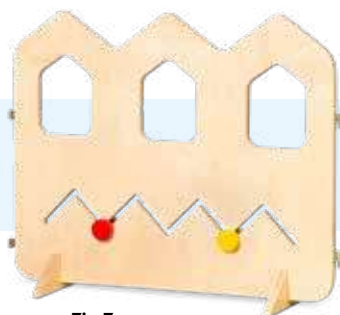

Zig-Zag
NS0087

- size: 81 x 63 x 22 cm



Mirrors
NS0086

- size: 81 x 63 x 22 cm



Horse
NS0088

- size: 81 x 63 x 22 cm



Maze
NS0089

- size: 81 x 63 x 22 cm





Each piece serves a different task (e.g. finding the way in a maze, binding, sorting). The elements can be joined with colour laces.

- 3 elements;
- length approx. 2,0 cm, height 90 cm;
- made of MDF laminated



House
NS1827



Train
NS1828



different manipulative activity on each wall

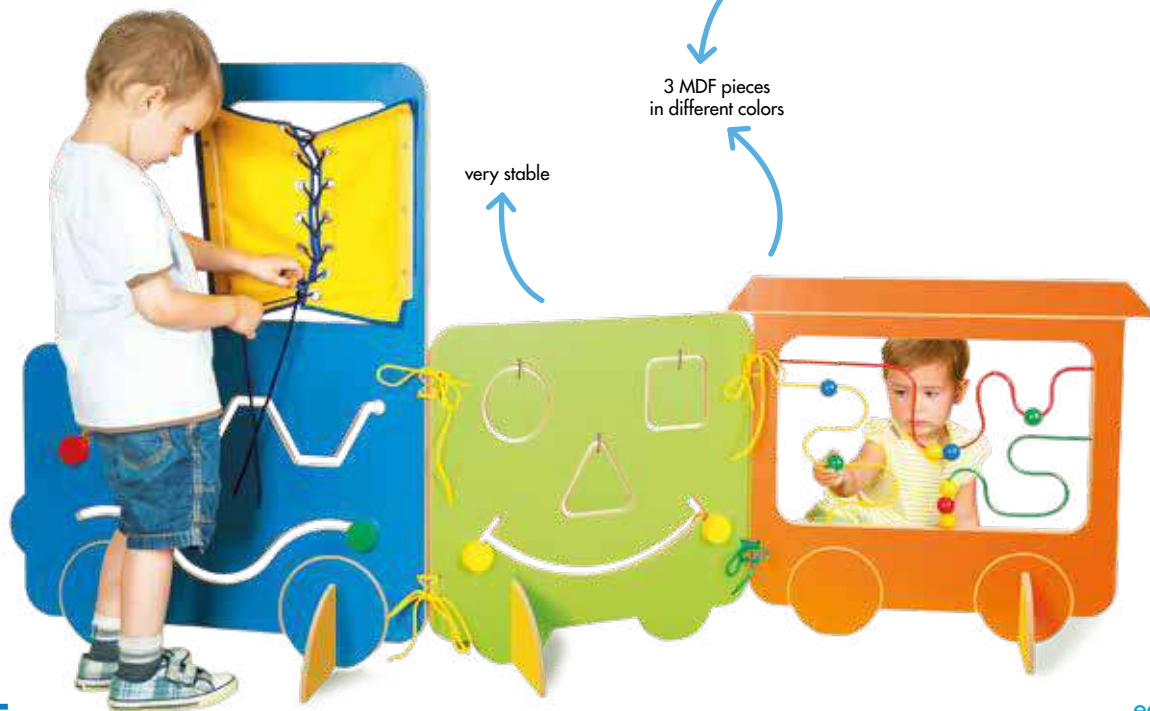

3 MDF pieces
in different colors

very stable

MANIPULATIVE CORNERS



Castle manipulative walls NS1717

A tower-shaped activity corner with 4 different panels on 4 walls: a flower with a safe mirror, a puzzle piece with a square maze,

a puzzle piece with a triangular maze, a double-handed maze Snails.

- size: 72 x 72 x 1,4 cm



Bear interactive kiosk NS1716

Multimedia kiosk is a bear-shaped stand for a tablet intended specially for children. The furniture will perfectly fill the space in play corners and provide educational

entertainment for the youngest. The kiosk has been very carefully designed. The white framework is made of laminated particleboard, with the bear-shaped front made of MDF board.

- size: 90 cm x 40 cm x 1,0 cm





Manipulative house NS0310

Its frame is made of 12 mm MDF board in red/blue/yellow colour. The play corner provides enough space for a few children to stand near the walls at the same time and it's also accessible to those on wheelchair. A two-sided mosaic with wooden rings (in 4 colours) encourages engage in many group activities. Wooden, adjustable tracks act as trails for wooden balls while a two-sided labyrinth, a counting frame

and a clock help in teaching to recognise different rhythms, colours, shapes. Thanks to them little ones can learn to count and read time. Moons and stars carved in the ceiling create a fairy-like atmosphere. The construction of the walls allows you to mount them either side.

- a freestanding play corner;
- dim.: 120 x 120 x 1,0 cm;
- the house consists of 468 wooden rings (diameter: 4,7 cm), 3 wooden balls (diameter: 7 cm), a clock, threading pads (diameter: 30 cm) and 40 x 40 counting frame with 100 beads



Manipulative mushroom with hat NS0436

A play corner in the form of a mushroom equipped with numerous manipulative accessories, such as spatial mazes, wooden blocks, laced tapestries and mirrors. You can hide under the hat or take it off and

put it on the floor, thus creating a mini-slide, or turn it upside down as a soft saucer to learn balance.

- dim.: 120 x 120 x 130 cm;
- material: structure made of hardwood plywood 18 mm thick, hat made of polyurethane foam and PVC fabric, accessories made of PVC, metal, cotton fabric and wood





Manipulative castle NS9088

A castle made of plywood offering many options of creative and engaging manipulative play. Among the movable parts, there are gears, an opening window with the possibility of closing it, rotating elements, differently shaped labyrinths and a mesh above the castle's entrance. Additionally, the castle is equipped with textural fragments and mirrors which stimulate the sense of sight. This manipulative castle awakens curiosity in children thanks to the movable parts and it develops their imagination through playtime involving roleplay.

- dim.: 75 x 110 x 75 cm



Manipulative school bus NS9087

A bus made of plywood offering many options of creative and engaging manipulative play. Among the movable parts, there are colourful, big gears, colourful rotating elements with mirrors on the other side, differently shaped labyrinths, a steering wheel and a gearbox. Additionally, the bus is equipped with textural fragments and mirrors. Inside, there is a comfortable, soft seat in grey colour attached with Velcro. This manipulative bus awakens curiosity in children thanks to the movable parts and it develops their imagination through playtime involving roleplay.

- dim.: 110 x 65 x 70 cm



MANIPULATIVE AND SENSORY BOARDS

ANIMALS

Educational boards for pieces used in sensory activities. Each board represents a habitat typical of particular animals. Elements are attached safe to the board by velcro.



Pigeon
NS0333

• size: 21 x 20,5 cm



Bullfinch
NS0334

• size: 21 x 18 cm



Tit
NS0335

• size: 17 x 20 cm



Cloud
NS0332

A wall board with sensory elements: pigeon, bullfinch and tit.

• size: 83 x 52 cm



Frog
NS0330

• size: 17 x 23 cm



Snail
NS0331

• size: 17 x 14 cm



Duck
NS0329

• size: 17 x 23 cm



animals attached with velcros

Fish
NS0328

• size: 17 x 16,5 cm



Pond
NS0327

A wall board with sensory elements: fish, duck, frog and snail.

• size: 90 x 45 cm

FANTASY



Meadow NS1260

Table with manipulative mazes and numerous sensory elements like artificial grass, PVC, coconut fibre, velour, felt.

- size: 118 x 3,5 x 75 cm



Jungle NS0893

A board with sensory elements: a monkey with a fluffy tummy, a lion with a mane, elephant's skin, tree bark, grainy soil.

- size: 119 x 76,5 cm

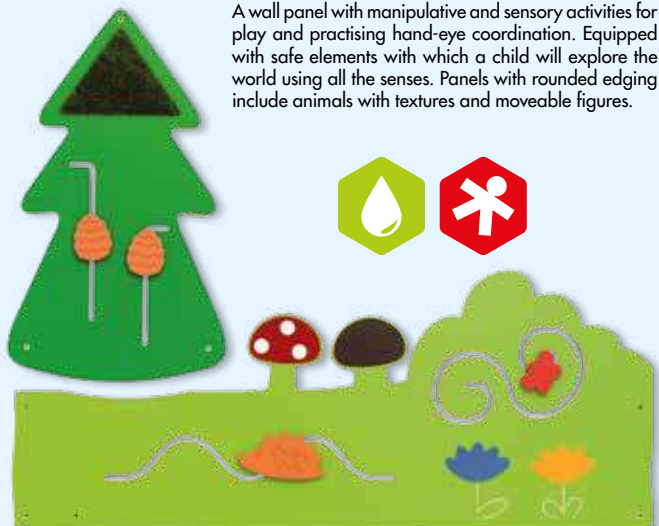

A wall panel with manipulative and sensory activities for play and practising hand-eye coordination. Equipped with safe elements with which a child will explore the world using all the senses. Panels with rounded edging include animals with textures and moveable figures.

Forest NS9078

- tree size: 44 x 75,5 cm;
- grass size: 130 x 52 cm;
- age: 3+

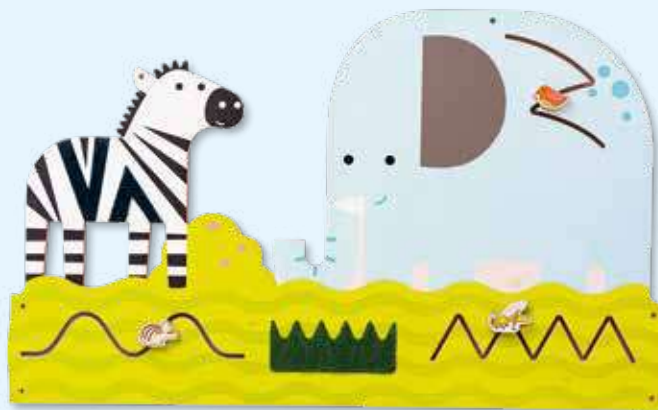
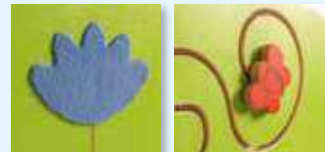

Zebra and Elephant NS9077

- size: 130 x 79 cm;
- age: 3+





Forest. Manipulative board

NS9090

- manipulation board, forest themed;
- the board is made of MDF board with a UV print;
- it is equipped with 3 movable elements,

- 4 elements with texture and 1 rotating element;
- the board is made of MDF board with a UV print;
- dim.: 130 x 79 cm



Farm. Manipulative board

NS9068

- manipulation board, farm themed;
- it is equipped with 2 movable elements,

- 3 elements with texture and 1 rotating element;
- the board is made of MDF board with a print;
- dim.: 130 x 79 cm





Royal. Manipulative board

NS9092

- manipulation board, kingdom themed;
- it is equipped with 1 movable element, 6 elements

- with texture and 4 rotating elements;
- the board is made of MDF board with a print;
- dim.: 130 x 79 cm



Wave. Manipulative board

NS9091

- manipulation board, sea themed;
- it is equipped with 2 movable elements, 2 elements

- with texture, 1 mirror, 3 Velcro elements and 1 plexi rotating element;
- the board is made of MDF board with a print;
- dim.: 130 x 79 cm



MANIPULATIVE BOARDS

NATURE

- made of MDF laminated

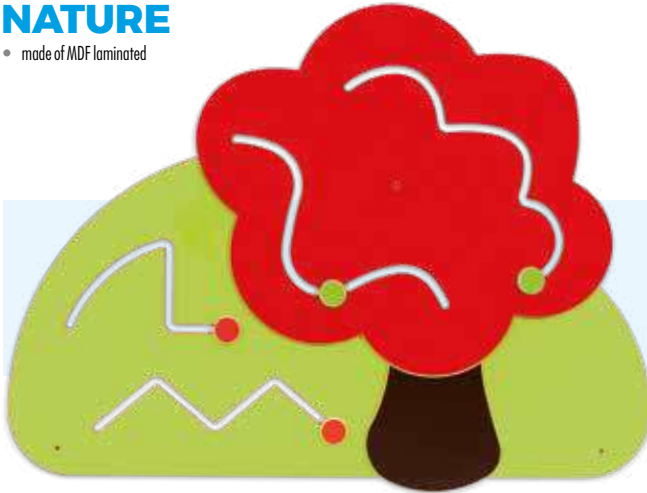

Manipulative Tree
NS3047

- size: 118 x 89 cm

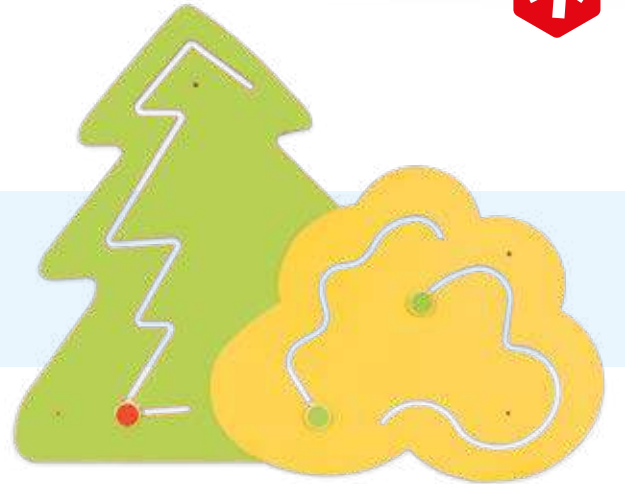

Manipulative Christmas Tree
NS3046

- size: 118 x 95 cm



Carrot
NS1029

- 2 labyrinths of different difficulty levels;
- size: 88 x 40 cm;
- MDF wall hanging with movable manipulative elements



Bush
NS3087

- velcroed flowers (3 pcs);
- size: 32 x 41 cm

MIRRORS

- size: 50 x 70 cm;
- can be fixed on the wall

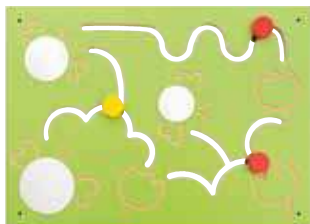

Bees
NS0992



Cats
NS0993

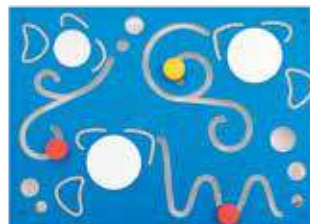

Fish
NS0994



Flower with Mirror
NS1028

- for use with both hands simultaneously;
- mirror in the center is great for logopedic exercises;
- ø 67 cm;
- MDF wall hanging with movable manipulative elements

PUZZLE

They can be joined together in one big board to be fixed on the wall.

- size: 50 x 50 cm



Snail
NS0988



Cat
NS0989



Rooster
NS0990



Fish
NS0991



ANIMALS

- made of MDF laminated



MANIPULATIVE BOARD

Educational boards with manipulative elements in the form of various types of closures useful in everyday life. Delicate colors and animal patterns encourage children to play and learn. By interacting with various accessories, children not only practice fine motor skills and hand-eye coordination, but also learn how objects such as zippers, buckles, laces, bolts, hooks and gears work.

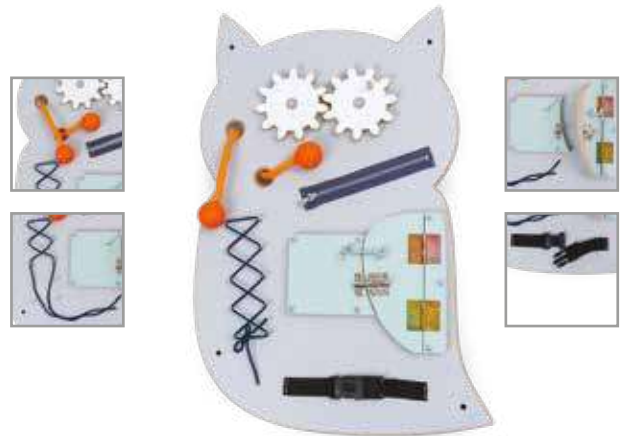

Manipulative board. Owl

NS9064

An owl-shaped manipulative board with gears, wooden balls on a string, a zipper, laces, a buckle on a belt, doors with a hook and a latch. Mounting: on the wall.

- dim.: 43 x 60 cm;
- material: 12 mm MDF board in grey colour;
- age: 3+

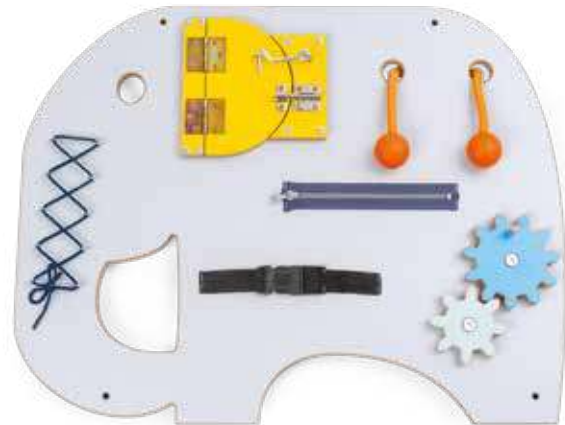

Manipulative board. Elephant

NS9065

An elephant-shaped manipulative board with gears, wooden balls on a string, a zipper, laces, a buckle on a belt, doors with a hook and a latch. Mounting: on the wall.

- dim.: 47 x 60 cm;
- material: 12 mm MDF board in grey colour;
- age: 3+

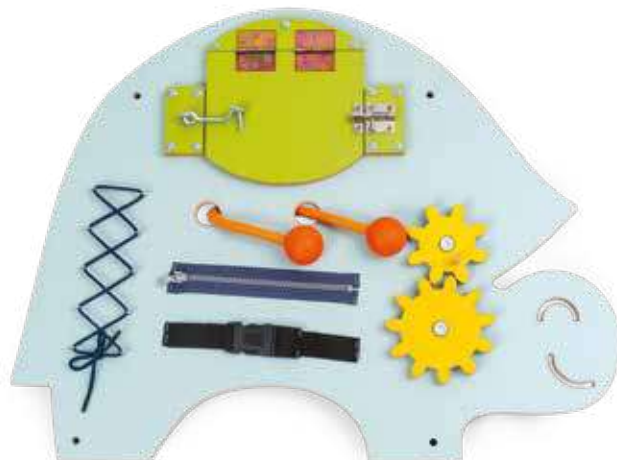

Manipulative board. Turtle
NS9066

A turtle-shaped manipulative board with gears, wooden balls on a string, a zipper, laces, a buckle on a belt, doors with a hook and a latch. Mounting: on the wall.

- dim.: 47 x 60 cm;
- material: 12 mm MDF board in mint colour;
- age: 3+

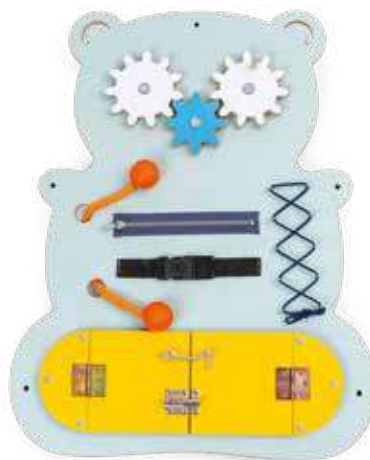

Manipulative board. Teddy bear
NS9067

A teddy bear-shaped manipulative board with gears, wooden balls on a string, a zipper, laces, a buckle on a belt, doors with a hook and a latch. Mounting: on the wall.

- dim.: 47 x 60 cm;
- material: 12 mm MDF board in mint colour;
- age: 3+

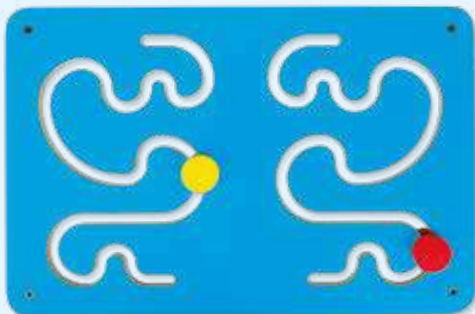

Snail racing
NS0359

- size: 40 x 60 cm

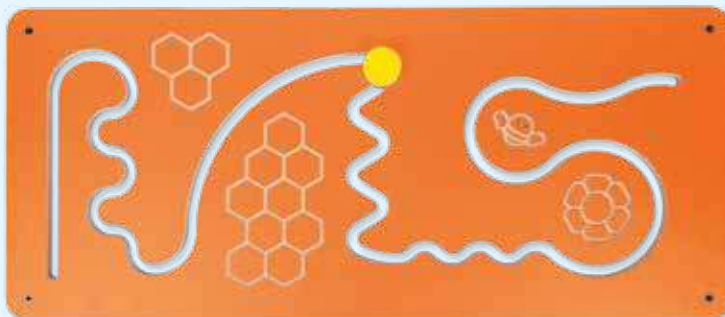

Bee
NS0358

- size: 40 x 92 cm

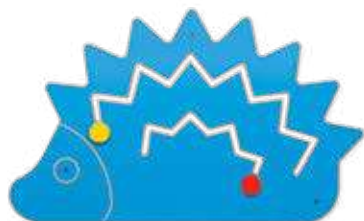

Hedgehog
NS1030

- 2 labyrinths of different length;
- size: 62 x 50 cm;
- MDF wall hanging with movable manipulative elements





Crocodile
VG5023

- size: 91 x 6 x 32 cm
- age: 12 m+

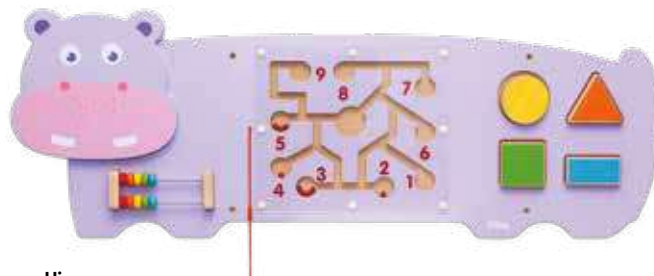
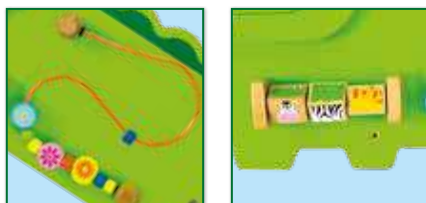

Hippo
VG5047

A board with a small abacus, magnetic maze and shape sorter.

- size: 91 x 4,5 x 32 cm

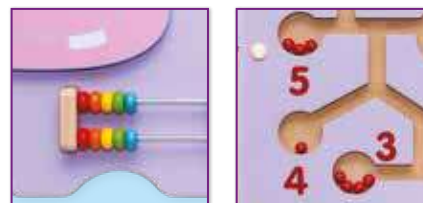

Bear
VG5471

A board with a mirror, magnetic maze and gears.

- size: 91 x 6 x 32 cm





**Wall toy wire boards Horse
VG0678**

A wall toy with turning gears and moving wire beads. Press the wood bar on the left end of wire and you can shoot the beads onto the wire top.

- size: 36 x 4,5 x 55 cm



**Wall toy abacus Frog
VG0679**

Wooden abacus wall toy made of high quality solid wood.

- size: 36 x 4,5 x 55 cm



**Wall toy mosaic fruits Giraffe
VG0680**

A wall toy of 4 block puzzles depicting different fruits.

- size: 36 x 4,5 x 55 cm



**Wall toy manipulative Zebra
VG0681**

A panel with 8 wooden shapes on string to match to their proper places on the board

- 8 shapes: circle, triangle, rectangle, square, heart, pentagon, star, oval;
- size: 36 x 3,5 x 55 cm;
- age: 18 months+

BEARS



Manipulative boards in the shape of an adorable bear which offer different manual activities. The presence of moving parts promotes child's development and stimulates their

senses. They not only help children to improve their logical thinking, visual and motor coordination, but also develop independence and increase concentration.



Manipulative board with optics VG4551

- dim.: diam.: 30 cm; moving parts: 3 discs with prints;
- fitting elements: 2 x screws, 2 x wall plugs;
- material: wood; age: 18 months +



Manipulative board with gears VG4553

- dim.: diam.: 30 cm; moving parts: 5 gears, 3 fans;
- fitting elements: 2 x screws, 2 x wall plugs;
- material: wood; age: 18 months +



Manipulative board. Rainbow VG4555

- dim.: diam.: 30 cm; moving parts: disc with colours;
- fitting elements: 2 x screws, 2 x wall plugs;
- material: wood; age: 18 months +

FANTASY



Rainbow. Manipulative wall board VG4642

5-piece manipulative board with engaging elements, like: moving gears, a forecast panel (a thermometer, a wheel with beads, a weather wheel, seasons window), a shape sorter, a music and optical panel (concave and convex mirrors, a bell, a xylophone with a stick) Maze panel: a spatial labyrinth, a day-night board.

- dim.: 162 x 11 x 82 cm; material: MDF board
- age: 18 months +



Unicorn. Manipulative wall board VG4654

4-piece manipulative board with engaging elements: a xylophone, a bell,

a stick, a rattle, a magnetic labyrinth, moving gears, a spatial maze, an abacus for sorting shape, concave and convex plexiglass mirrors, a movable eyelet.

- dim.: 84 x 67 x 10 cm; material: MDF board
- age: 18 months +



BIG

**Caterpillar.
Manipulative board
VG4557**

Multifunctional Caterpillar board equipped with many manipulative elements which train the eye-hand coordination of the youngest. The board is divided into 5 parts. Each of them encourages children to be active in different ways. The caterpillar's head has got a winding track for moving wooden beads. Next, there is a part with reels that provide interesting visual effects depending on the speed

at which the board spins. The third part introduces the subject of derived colours, created by mixing primary colours. Then, there is a part with small doors. Inside are hidden materials with different texture, like: Velcro, mirror, felt fabric. The last part consists of a labyrinth track with the possibility of connecting elements with each other.

- dim.: 185 x 12 x 83 cm; age: 3+



**Wall Toy. Airplane
VG5014**

A multifunctional wall toy with nice image of an airplane. Ideal toy for kindergarden, public kids' zone, waiting area as well as recreation room at home.

- includes: wire beads, a rolling disc with sound, a block slider, a trace-and-track toy, a clock with moving hands and turning gears;
- size: 180 x 5 x 66 cm
- age: 1+



**Wall Toy. Crocodile
VG5034**

This wall-mounted manipulative table is divided into 5 sections, each of which enhances motor and coordination skills in a different way. The table has manipulative mazes,

bead circle, interlocking cogs, bells, mirror, magnetic maze, spatial mazes with beads.

- size: 187 x 1,5 x 61 cm;
- age: 1+



WALL PANEL



Frame for wall panels
NS3073

A safe and ergonomic wood and tin frame for attaching wall pannels.

- size: 53 x 6 x 45 cm;
- material: tin 0,2; alderwood 2 cm; white + raw wood



Wall panel - Tic Tac Toe
NS9081

Wall panel for the traditional tic-tac-toe game. The set includes rotating squares with the symbols X and O and an abacus for keeping the score. It helps to develop logical thinking, creativity and improves the imagination while training motor skills.

- dim.: 45 x 4,5 x 50 cm;
- material: laminated MDF board in a natural and white colour; age: 4+
- use frame NS3073 for wall installation



Optics
NS3075

A wall panel to demonstrate the basic tricks of the light using 3 replaceable mobile elements.

- white laminated board; size: 50 x 3 x 45 cm;
- use frame NS3073 for wall installation

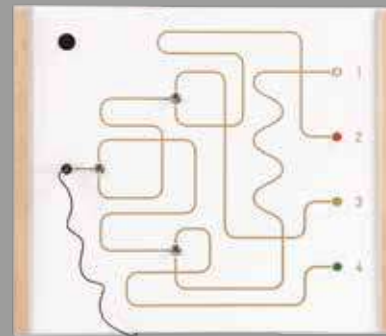

Electricity
NS3096

A wall panel to demonstrate how electric current flows. By operating switches the child can direct the current and let particular light bulbs come on.

- white laminated board; size: 50 x 3 x 45 cm;
- 3 AAA batteries required (not included);
- use frame NS3073 for wall installation

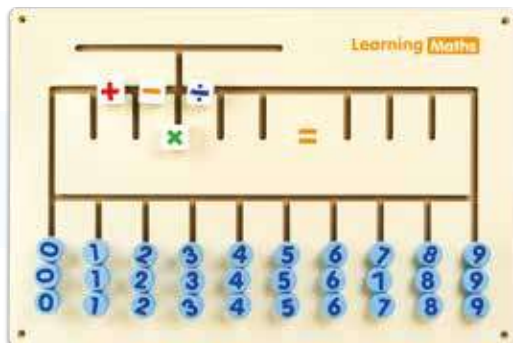

Learning Maths VG0675

An ideal toy for learning maths. Use the numbers and arithmetic signs to do basic arithmetic.

- size: 60 x 3,5 x 40 cm

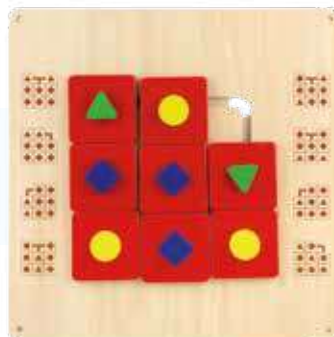

Shape Maze VG5043

A wall-mounted logic puzzle based on moving differently-shaped elements to fit the spaces according to 8 patterns painted on the sides of the table.

- size: 47 x 5 x 47 cm



Magical house with locks VG1627

A manipulation board featuring a house with openable shutters. 6 pairs of doors conceal images of animals and objects. The toy requires a child to find a way to open different types of locks. The panel can be mounted on a wall.

- size: 44 x 3 x 44 cm; age 18 months+

LABYRINTH FOR FEET

The wall labyrinth for playing and for exercising the feet. Activity with the panel stimulates motor development and helps to strengthen the muscles of the legs, knees and feet. This product has to be attached to the wall.

- dim.: 30 x 80 x 3,5 cm;
- material: MDF board, colour may vary;
- self assembly required;
- Velcro fastening of the feet;
- age: 3+



- yellow
NS9079



- blue
NS1844

MANIPULATIVE EASELS

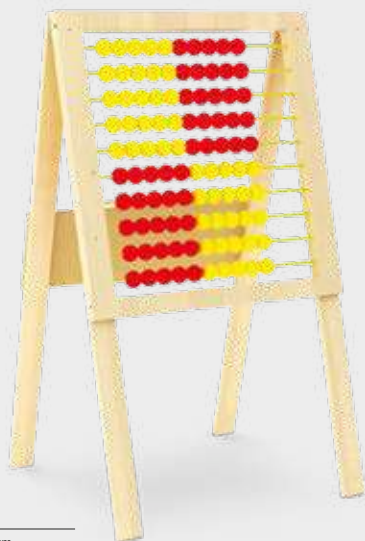

Abacus
NS0543

- size: 120 x 68 x 60 cm



Magnetic
NS0835

- size: 120 x 68 x 60 cm



HANDS



Lazy Snake
NS9082

Round board with a track, wooden ball and handles for easy manipulation. While playing, the students should handle the board in a way that would make the ball move along the track. The goal is to prevent the ball from falling. This activity develops manual dexterity, improves hand-eye coordination, but also concentration.

- size: 32 x 3 x 28 cm;
- material: MDF board, 12 mm thick in blue, red wooden ball, dia. 18 mm; age: 3+



Labyrinth. Steering wheel
NS9083

Labyrinth with a metal ball, perfect for fine motor skills, eye-hand coordination and concentration exercises. 4 handles and acrylic glass, which prevents the ball from falling out, makes using this product much easier.

- dim.: 40 x 1,5 x 40 cm;
- material: blue MDF board, 12 mm, acrylic glass, a metal ball;
- age: 3+



Labirynth Eight NS0421

- size.: 48 x 22 x 2,5 cm; ball ø 3 cm



Eight track - concentration training WP0019

An eight equipped with handles on the sides to facilitate the manipulation of the toy. It's raised sides prevent the ball from falling of the track. This toy develops manual skills, improves eye-hand

coordination but also concentration. It activates and integrates both cerebral hemispheres and improves binocular vision.

- dim. of the product: 34 x 5 x 22 cm;
- ball included in the set;
- material: plastic; age: 3+



Rabbit box. Topology worksheets UT0037

Fantastic logic game which includes 3 wooden bricks, a bunny and a set of activity cards with varying degrees of difficulty. The children's task is to arrange the elements of the set in such a way as to obtain the pattern presented on the card. This game introduces children to the concepts of: higher/lower, up/down,

outside/inside, visible/hidden, etc. It also teaches about colours, shapes and depth perception as well as develops manual skills, eye-hand coordination, imagination and logical thinking.

- dim.: of the box: 9,5 x 9,5 x 9,5 cm;
- dim. of the yellow and red element: 7,5 x 3,5 x 7,5 cm;
- dim. of the bunny: 4,5 x 11 cm;
- 60 activity cards, dim.: 9 x 9 cm;
- instruction; age: 3+

MAGNETIC WALL BOARD

A wall board with dry-wipe and magnetic surface. These qualities allow children to place magnetic bricks, letters, numbers, or puzzles (sold separately) on the board. All additional elements can be kept on a practical, wooden shelf. Dry-erase markers are suitable for writing on the surface (sold separately).



MAGNETIC BOARDS



Car
VG0782

- meas. when assembled 197 x 108 x 9 cm;
- the set includes: 54 screws, 54 rawlplugs, 18 elements of the train;
- weight: 19 kg;
- material: wood; age: 3+;
- meas. of the packaging: 41 x 41 x 30 cm;



Castle
VG0775

- 4 dry-wipe, magnetic panels, 4 wooden shelves for accessories, 4 wooden decorations, 33 screws, 33 expansion bolts;
- dim. after the assembly: 154 x 9 x 60 cm;
- material: wood, metal;
- age: 3+

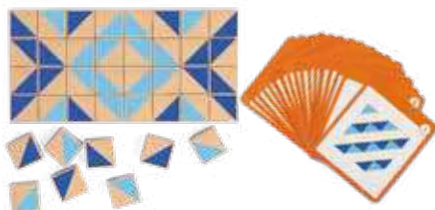

Symmetry bricks with worksheets
VG0642

Magnetic bricks perfect for fun games on the board. Thanks to the 20 boards with 40 images of possible bricks arrangements, children can improve their problem-solving skills, critical thinking and creativity. The set is kept in a cotton bag to prevent its elements from getting lost or damaged.

- age: 3+

Rich sets of magnetic puzzles which, when arranged, form colourful depictions of fruits, vegetables, animals, or vehicles. Each product consists of 8 four-piece puzzles. Their additional advantage is the possibility to arrange the puzzles on any magnetic surface. These puzzles are a great way to improve concentration, logical thinking and motor skills. Each set contains a cotton bag to store the puzzles.

- dim.: 4 x 1 x 4 cm;
- material: wood, magnet; cotton bag;
- age: 18 months+



Animals
VG0722

- 8 four-piece puzzles: sheep, cow, horse, rooster, lion, monkey, crocodile, elephant



Fruits and vegetables
VG0700

- 8 four-piece puzzles: bananas, strawberry, apple, grape, pepper, aubergine, carrot, broccoli



Vehicles
VG0723

- 8 four-piece puzzles: railway engine, rocket, helicopter, ship, fire truck, police car, ambulance, plane

PRE-WRITING WALL BOARDS



Colour MDF wall hangings – borders are intended to prepare the child for writing.

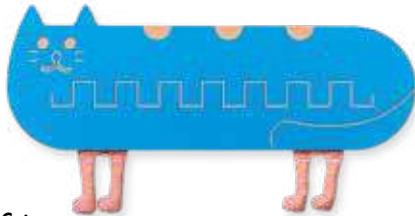

Cat
NS0317

• size: 92 x 32 cm



Lamb
NS0319

• size: 92 x 40,5 cm

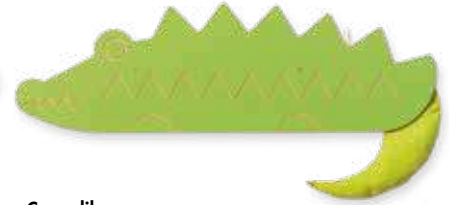

Crocodile
NS0320

• size: 92 x 28,5 cm



Calf
NS0324

• size: 69 x 1,2 x 45 cm

Cow
NS0323

• size: 89 x 1,2 x 55 cm

alphabet can
be customized

GRAPHOMOTOR TILES

A set of graphic borders to support hand-relaxing exercise, supplemented with magnets. Three levels of difficulty (marked with colour and line distances in the border). Each set includes 4 plastic dry-wipe writing boards.

- size: 98 x 17 cm



Set 1 – green
NS3007



Set 3 – red
NS3009

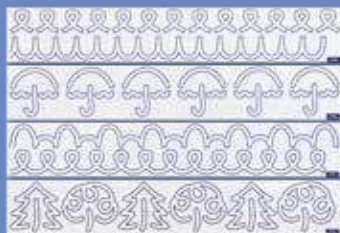

Set 2 – blue
NS3008



GRAPHIC WORKSHOP

- 4 plastic folders 21 x 30 cm;
- 30 cards with patterns;
- 10 washable markers

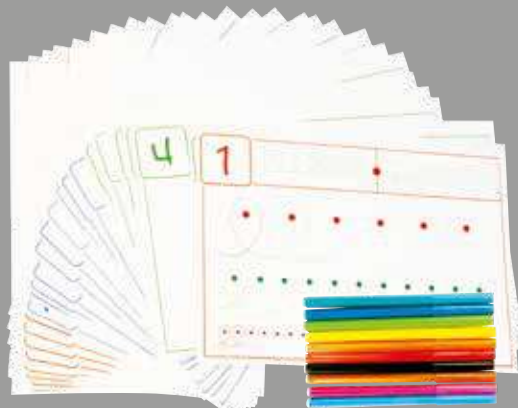

Graphic Workshop 1
NS0005



Graphic Workshop 2
NS0006



GRAPHICAL EXERCISE SET



Set 1
NS3040

- yellow, green, orange;
- size: 35 x 14,8 x 5 cm;
- made of MDF painted



Set 2
NS3041

- violet, navy blue, red;
- size: 35 x 14,8 x 5 cm;
- made of MDF painted



Toddler Tracking Board 1
EN1034

- size: 30 x 30 x 2 cm;
- made of plywood varnished
- age: 2+



SMALL BOARDS



DRY-ERASE BOARDS



Board 1
NS0897

- size: 26 x 22 cm



Board 2
NS0898

- size: 26 x 22 cm

GRAPHOMOTOR PLATE BOARDS

- manipulative MDF plate
- size: 30 x 21 cm



Board 1
NS0895

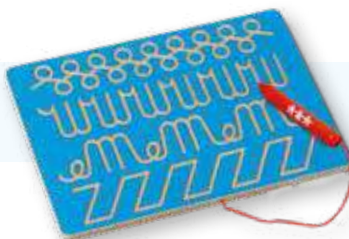

Board 2
NS0896

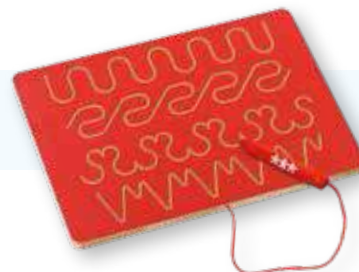

Board 3
NS0891



Letter-like pattern
NS9175

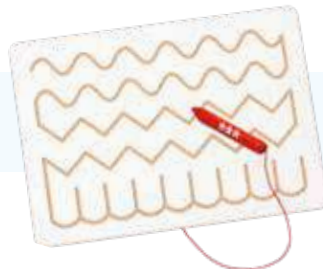

Left-right
NS9176



Flowers
NS9177



Wood and Mushrooms
NS9178



Prewriting board set
EN1030

- Set of 4 wooden boards
- size: 33 x 10 x 1,8 cm; age: +3



DOUBLE HANDED GRAPHOMOTOR BOARDS

By guiding a wooden pencil on the pattern a child develops co-ordination and prepares the hand for learning to write letters. Suits children with clear right- or left-handedness.

- made of MDF;
- size: 30 x 21 cm



Kites
NS3037



Stars
NS3038



Snails
NS0892



Flowers
NS3039



Musical Notes
NS0368



Pears
NS0367

SMALL BOARDS MAGNETIC

- made of MDF laminated

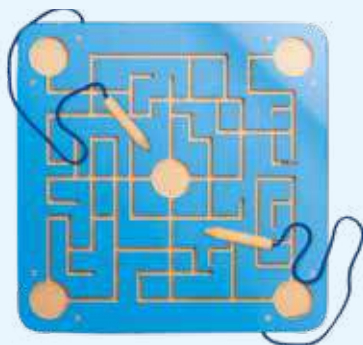

Labyrinth. Magnetic maze

NS3058

- size: 40 x 40 cm



Numbers. Magnetic maze

NS3101

The aim of the game is to lead a metal ball through a tunnel with a magnetic rod. Children learn letters, numbers and develop graphomotor skills preparing them to learn to write



- supplied with wooden peg;
- size: 40 x 40 x 1,5 cm
- 2 wooden magnetic pens on strings
- age: 3+

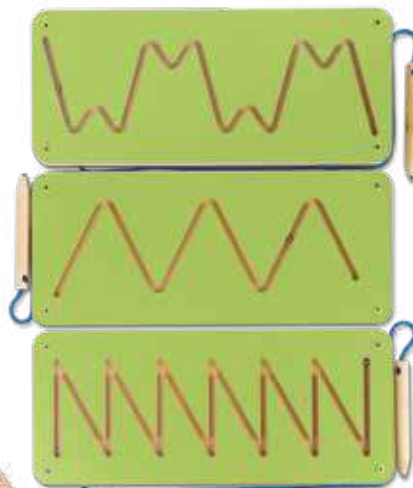

Magnetic patterns 1

NS3056

- size: 35 x 15 cm

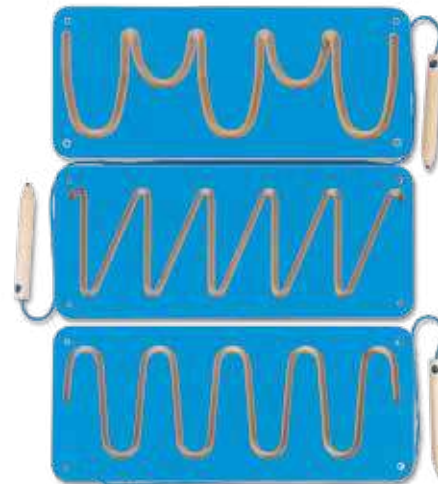

Magnetic patterns 2

NS3057

- size: 35 x 15 cm





Labyrinths EO0517

- size: 29,5 x 29,5 cm; made of plywood



Ants EO1113

- size: 29,5 x 29,5 cm; made of plywood



Magnetic owls maze EO1307

- size: 28 x 1,6 x 24 cm; made of plywood age: 2+



Candy Jars EO1308

- size: 35,5 x 1,5 x 23,5 cm;
- 10 worksheets; made of plywood



Finding a parking space EO1407

- size: 35,5 x 1,5 x 33,5 cm;
- 5 worksheets; made of plywood



Magnetic shapes maze EO1509

- size: 29,5 x 19 x 1,8 cm; age 3+
- includes 8 worksheets; made of plywood
- materials: wood, plastic; magnet, plexiglass



Seek and count EO1607

- size: 29,5 x 1,8 x 35,5 cm;
- made of plywood



Magnetic colour maze EO1972

- materials: wood, magnet, plexiglass; age: 3+;
- made of plywood



Numbers EO5229

- size: 29,5 x 29,5 cm;
- made of plywood

GRAPHOMOTOR TILES

Tiles with textured patterns. Moving a finger along a rough line stimulates the sense of touching and improves visual-motoric co-ordination. The child learns new geometric forms and develops concentration. The exercise fits either hand. The 3D printed pattern is durable and clean (if necessary, it can be cleaned with a moist cloth).

- 10 MDF tiles, size: 15 x 1,2 cm x 15 cm

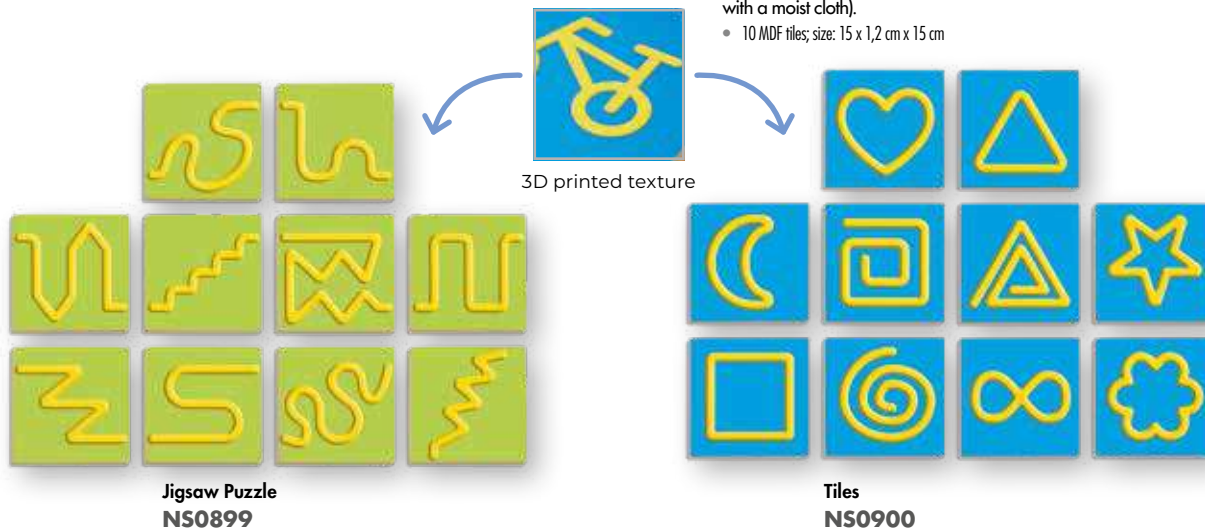

Set of 8 boards with textured 3D print. The clear texture with house and journey theme shapes, stimulates the sense of touch. The toy can be used as a help for blind and visually impaired children.

- set of 8;
- size: 12,5 x 12,5 cm;
- made of 6mm MDF



Home. 3D Sensory pictograms
NS9179

A set of 8 plates featuring domestic objects.



Traveling. 3D Sensory pictograms
NS9181

A set of 8 plates featuring objects connected with travelling.

MANIPULATION

LABIRYNTHS



Mini bead pastel maze CI4143

A manual toy - 15 acrylic beads for a child to slide on a metal track.

- 1 pc; base 9 x 1,8 cm, height 12-13,3 cm;
- model selected randomly;
- age: 18 m+

Mini bead maze VG0047

A spatial mini maze in which colourful beads are slid along metal tracks.

- 1 pc; size: 9 x 13,5 cm;
- model selected randomly;
- age: 1+

Wooden pastel manipulative cubes CI4334

Each side poses a different manipulative challenge to the child. The toy teaches logical thinking and patience and it helps distinguish shapes and colours.

- size: 28 x 26,5 x 42 cm;
- activities: rotatable maze with beads, 4-element jigsaw puzzle with a unicorn, shape sorter, bead frame, manipulative maze;
- age: 18 months+



Forest on table NS0537

A set of colourful spatial manipulative mazes on a round table.

- top ø 70 cm; table H 42 cm;
- total H 92 cm



Multi-activity cube CI0740

- size: 29,5 x 29,5 x 58 cm





Animals.
Wooden manipulative table
VG4083

Short table equipped with many different manual and musical elements: a shape sorter, a stacking tower toy with a pin, moving gears, „Animal Path“ labyrinth,

a spatial labyrinth, a xylophone, a cymbals. Additional pieces: 5 stacking tower blocks, a stick for playing the xylophone and cymbals.

- dim.: 29,5 x 29,5 x 22 cm;
- material: wood, metal;
- age: 18 months +

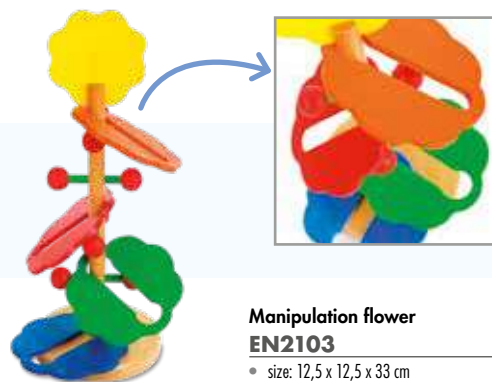

Manipulation flower
EN2103

- size: 12,5 x 12,5 x 33 cm



Rollercoaster Table
VG0670

Big enough for several children to play together. Multiple functions: rollercoaster of colorful wires with wooden beads; movable blocks

(a farmer, a tractor and 3 animals) on a track; turning gears and a windmill. The table legs are made of solid beech wood with secure connection to the table top.

- size: 60 x 81 cm

SORTERS



**Wooden pyramid with a sorter
VG4016**

Educational pyramid with a sorter in beautiful pastel colours will encourage fun activities. It contains 5 boxes in different shapes and 4 geometric brick made of solid wood. The children can not only stack or sort shapes, but also learn numbers. Each side of the box is enriched with various attractions: 1 to 5 numbers, colourful animals (bear, elephant, lion, fox, rhino), sorter's openings (square, circle, triangle, heart, star) and illustrations matching the number on the other side (traces of a bear, fish, honey jars, mushrooms, tree).

- 9 pcs: 5 boxes, 4 bricks;
- meas. of the pyramid: 9 x 33 x 9 cm;
- material: wood;
- meas. of the packaging: 9 x 9 x 9 cm;
- weight: 0,5 kg; age: 12 months +



**Bear with shapes
FT5094**

A teddy bear sorter with many differently shaped holes. The children's task is to put the blocks in the corresponding holes.

- bear's height: 21 cm ball's diameter: 13 cm;
- set includes 6 blocks material: plastic;
- age: 1+



**ZOO car sorter
NS0369**

A wooden sorter shaped like a car with a string. The pening is located on the back of the toy. The pening is located on the back of the toy. The set includes 6 animal and 2 human figurines. This toy expands imagination, creativity and offers children many interesting activities.

- 7 pcs: 6 animals: a zebra, a rhino, a crocodile, a lion, an elephant, and a giraffe;
- dim. of the car: 27 x 13 x 15 cm;
- material: wood
- age: 18 months +



**Sorter with blocks
NS4076**

A hexagonal plastic sorter which assists children in learning to recognise basic geometric shapes.

- 16 pcs.: 15 differently shaped and pointed blocks;
- sorter: 14 x 14 x 14 cm;
- material: plastic;
- age: 18 months +



**Elephant on wheels - sorter
FT5388**

An elephant-shaped sorter for toddlers (12 months+). It stimulates logical thinking and teaches little ones to recognise different shapes, colours. Additionally, it promotes the development of manual skills. The sorter is equipped with a piston which when pressed makes all blocks move inside. The toy is made of high-quality plastic.

- 5 blocks in 5 different colours: yellow, red, blue, purple, orange;
- box's dim.: 24 x 17 x 16,5 cm;
- material: plastic
- age: 1+



Cylinders
NS0312

- size: 23 x 18 cm



4 figures
NS0153

- base size: 48 x 9,5 cm, element H ca. 7 cm



Geometrical peg grading board
NS0375

- base size: 17,5 x 17,5 cm; 16 blocks



Maze puzzle
VG5096

- 4 different shapes in many colours
- size: 30 x 8 cm; 18 m+



Geometric stacker
VG5067

- The elements of the toy need to be matched for shape and size and stacked onto the right rods.
- 29 elements: base with 3 rods, 25 blocks in 3 shapes and 7 colours;
 - size: 28,9 x 21 cm; age: 2+



Frog stacker
VG0258

- A stacker to teach about colours, sizes and sorting.
- 7 elements: base with a pole, 5 colourful pegging rings, frog head piece
 - size: 11 x 18 cm; age: 2+



Balancing wooden stacking sorter
CI3537

- 26 pcs;
- size: 30 x 7 x 11,1 cm;
- age: 3+



TRANSPARENT ABACUS



- with shapes JN0360

A multifunctional abacus (counting frame). It includes 3 sets of transparent blocks: figures (10 shapes in 5 colours), beads (6 shapes in 6 colours) and numbers (from 0 to 9). It's designed

for counting, sorting as well as learning about colours and numbers. The abacus helps to develop coordination and motor skills.

- dim. of the base: 30 x 5 x 8 cm with a mandrel;
- material: plastic;
- age: 3+



- for sorting numbers JN0030

Manipulative puzzle which not only develops motor skills of children, but it also improves their creativity and stimulates their interest in the world of colours and numbers. The set consists of 5 pins on which colourful hoops can be put. Transparent numbers, which additionally

help to visualise mathematical operations, were prepared with older children in mind.

- dim. of the whole set: 30 x 8 x 18 cm;
- contents: 50 hoops with dim. of 5 cm, 1 cm thick in: blue, yellow, red, green, orange;
- 5 transparent pins;
- 1 transparent base, dim.: 30 x 8 x 5 cm;
- 10 numbers (0-9) in: blue, yellow, red, green;
- material: plastic, packaging: plastic bag; age 3+



- for sorting shapes JN0031

The set of figures with an abacus will introduce the children to the world of sorting and recognising colours as well as objects' characteristics. This set consists of the elements which differ not only in colour, but also in shape. Play time will

train hand-eye coordination, fine motor skills and it will improve logical thinking.

- dim. of the whole set: 30 x 8 x 18 cm;
- contents: 50 figures (disc: dim. 5 cm, thickness: 1 cm) in 5 colours: red, yellow, green, orange, blue;
- 5 pins in green, 1 base in yellow;
- material: plastic;
- packaging: plastic bag;
- age: 3+

BLOCKS ON THE RODS

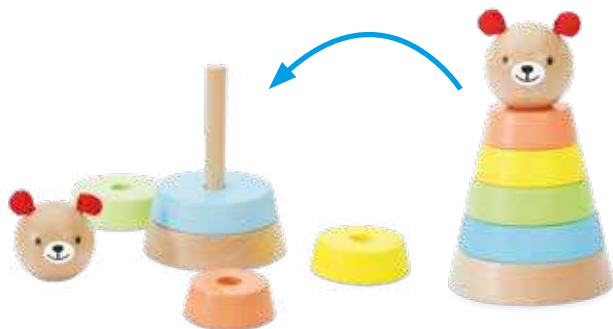

Wooden puzzle - bear CI0100

Classic wooden puzzle in the form of an adorable tower with a teddy bear. It is designed with four colourful and effective rings as well as the lovable teddy bear's head. Through arranging

the puzzle's elements children learn to organise objects according to their size, they improve logical thinking, dexterity and the ability to identify colours.

- 6 pcs: base with a rod, 5 bricks;
- dim.: 8,5 x 8,5 x 13,5 cm;
- material: wood; age: 1+



Block house TW2029

A set of wooden building blocks. Children can build a house by putting blocks on the mandrels. Activities with this set develop manual skills, coordination, and train concentration.

- 16 pcs;
- 14 colourful blocks, Roof, Base;
- dim.: 12 x 12 x 23 cm;
- material: wood;
- age: 1+



Little fisherman. Wooden dexterity toy CI0111

Rich set of elements, including magnetic ones, which offer 3 kinds of activity. Happy seal with fish allows children to train dexterity. The task is to place as many fish as possible on the seal's back. The seal has holes in the side wall with rods of various lengths inside them to create

a sorter for layering fish. Additionally, such an activity develops fine motor skills and logical thinking. Pond in the form of a round pad, magnetic fishing rods and fish allow children to organise a fishing contest.

- 24 pcs: 1 seal/ sorter base, 5 rods, 15 magnetic fish,
- 1 pond, 2 fishing rods;
- material: wood, magnet;
- age: 18 months +



Manipulative trees CI0102

Three adorable trees and animals which live on them: owl, woodpecker, squirrel. Elements of the set can be freely combined in order to create different shapes. The bricks can be

arranged on the base with a rod or on a flat surface. This toy helps to develop visual-motor coordination, logical thinking and recognition of shapes and colours.

- 16 pcs, 1 base, 15 bricks;
- dim.: 23 x 8 x 12,4 cm; material: wood; age: 1+



Stacking tower with worksheets EO1111

The task of the game is to build a tower by fitting all the elements shown in a pictorial instruction. The activity

develops the fine motor skill of positioning blocks with precision while following a worksheet or one's own design.

- 42 elements: 25 blocks, 5 round bases, 12 pictorial instructions;
- material: wood; dim. 11,5 x 11,5 x 16 cm; age 2+



City. Wooden Stacking Blocks VG0043

Stacking the blocks on the rods will create various constructions.

- 26 elements: 8 rods of different lengths, 4 bases in 4 lengths, 14 blocks in different shapes
- size: 23 x 6 x 19,5 cm; age: 18 months+



Pirate VG5074

Magnets are hidden inside the block which is safe for children to play with.

- 10 parts; size: 20 x 4,5 x 20 cm
- age: 3+



Little Red Riding Hood VG5075

Magnets are hidden inside the block which is safe for children to play with.

- 10 parts; size: 20 x 4,5 x 20 cm;
- age: 2+



Occupations Jigsaws EO1019

The aim of the jigsaw is to reconstruct figures representing different professions.

- 24 blocks, 5 worksheets, wooden base with 8 wooden pegs;
- size: 38 x 7,5 x 13,4 cm

LACING

Cotton reels. Lacing set IV0126

- 122 pcs;
- 6 coloured strings, 2 with plastic clips



String along lacing kit NS4084

The kit contains a plastic design board with slits to punch laces in with a special pen. The slits are built so as to block the lace and prevent it from moving. Children can create

their own designs or use the patterns cards included.

- 47 elements: 3 white boards 28 x 1 x 19,5 cm, 3 blue punch pens 11.5 x 0,5 cm, 40 laces, pattern cards;
- age: 3+

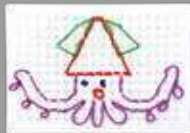

Thready Bears AP0010

Bear-shaped elements for lacing, sorting and counting.

- the set includes: 3 laces, 50 elements, plastic bucket;
- age: 3+



Box with threads and buttons NS4037

- box size: 21 x 29 cm;
- 368 pcs

Wooden beads NS0538

- 90 wooden beads, ø 3 cm;
- 5 laces, L 65 cm



Thread board. Lacing set 333122

- 8 plastic objects, H 12,5 cm in 4 colours;
- 9 strings, L 50 cm in 3 colours

Lace and trace board with worksheets NS4083



A lace & trace puzzle combining manual play with creative activity. Stick coloured laces (with your hand or a special pen) into the velcro surface of the board to conjure up pictures of your own design or to copy pictures suggested on worksheets. The activity develops patience, dexterity, precision of hand and finger movements and is great preparation for learning to write.

- 191 elements: 3 boards 28.2 x 1.2 x 22.2 cm, 6 tilting stands, laces of different lengths and colours, 3 lacing pens 13.5 x 1 cm, 8 double-sided worksheets 8 x 10 cm;
- age: 3+



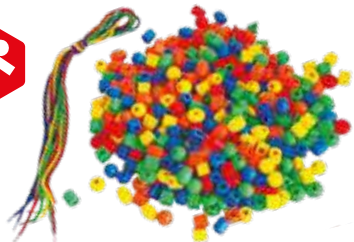

Plastic beads
NS4087

- set of 360 pcs (size: 2 x 1,5 cm) + multi-colour laces (L 90 cm)



Letters lacing
NS4089

- set of ca. 100 letters (size: 6 x 4 cm) and 15 multi-colour laces

LACING LETTERS

Thread letters onto coloured strings to make words!
A great toy to develop motor skills and literacy.

- 26 coloured upper and lower case letters;
- 8 coloured strings, ca. 15 cm



Lower case
AP0878



Upper case
AP0879



Sailboat. Lacing set
NS0524

- H 20 cm



Threading Apple
VG5627

Thanks to the spheric shape the toy is easy to grip and develops dexterity of both hands.

- size: 8 x 8,7 x 8 cm



Lacing Wild Animals
VG5132

The colorful lacing set features 4 adorable wild animals and 4 laces in different colors. Match the cute heads,

legs, arms and tails to same pattern underneath, then lace them to get 3D vivid animals.

- box size: 21 x 19 x 4,5 cm;
- age: 3 +



Big shoe. Lacing set
NS0357

- size: 28 x 9 x 9 cm



Cheese. Lacing set
NS0352

- size: 15 x 7 x 10 cm



Shoes. Lacing set
TB6320

- size: 30 x 22 x 1 cm





The set contains 5 different outfits which can freely mixed and matched. Playing with this set allows children to develop their motor skills and it boosts their creativity.



Dress-up game Occupations. Girl
CI0117

- there are 28 elements inside; dim.: 65 x 20 x 0,5 cm



Dress-up game Occupations. Boy
CI0118

- there are 27 elements inside; dim.: 65 x 20 x 0,5 cm

FURNITURE FOR PUZZLES

Puzzle cabinet NS0430

A practical cabinet with shelves for storing toys and puzzles, which can be easily lost. The cabinet may be placed on other NS cabinets, but it can be also used independently. It is possible to put two cabinets vertically.

- 1 x cabinet;
- dim.: 50 x 40 x 70 cm;
- material: chipboard in beech colour, 12 mm thick



WOODEN KNOB PUZZLES



Vehicles. Sound puzzle VG1274

A puzzle for the youngest which helps them recognize vehicles and sounds they make. After matching a piece with a vehicle to the right picture in the base the vehicle's characteristic sound can be heard.

- 8 elements: base 30 x 3,3 x 22,5 cm, 7 puzzle pieces with handles;
- age: 18 months+

Farm animals. Sound puzzle VG1273

A puzzle for the youngest which helps them recognize animals and sounds they make. After matching a piece with an animal to the right picture in the base the animal's characteristic sound can be heard. Each piece has a handle for easy manipulation. The puzzle develops motor skills and logical thinking.

- 8 elements: base 30 x 3,3 x 22,5 cm, 7 puzzle pieces with handles;
- age: 18 months+

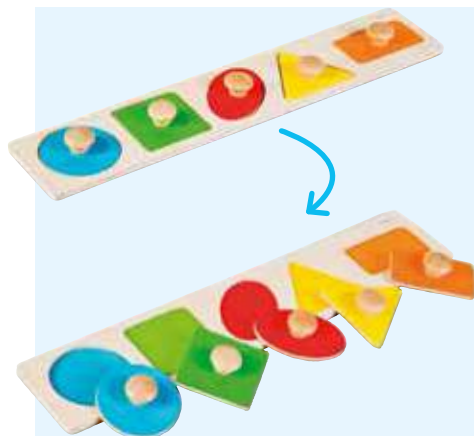

Geometry puzzle CI3950

- made of wood;
- size: 45 x 8,5 cm



Traffic puzzle CI3611

- size: 30 x 2 x 21 cm



Fruit puzzle CI3652

- size: 30 x 2 x 21 cm

PUZZLES



**Learning Space and Distance puzzle
VG0138**

Doublesided educational puzzle. One side is farm-themed, the other relates to the sea and pirates. The child's task is to place puzzle pieces in special grooves and then determine distances and spatial relationships between the inserted objects. Children learn concepts

such as „beside”, „in front”, „on one side”, „on the left/right”, „at the front/back” etc.

- 26 elements: 20 puzzle pieces, 5 doublesided pictorial instructions, a doublesided base 23 x 11 cm;
- age: 18 months+



**Animals and their food puzzle
VG1607**

A set of puzzle pieces to create 12 pairs of pictures featuring animals and their favourite foods.

- 24 elements: 12 pcs with image of animals, 12 pieces with foods;
- size: 21 x 4.5 x 19 cm;
- age: 18 months+



**Life cycle bundle.
Wooden puzzle
VG1609**

A jigsaw puzzle representing development cycles of plants and animals.

- 24 elements: 6 development cycles in 4 stage: butterfly, hen, sunflower, pumpkin, frog, apple;
- size: 21 x 4,5 x 19 cm;
- age: 18 months+



**Animal City. Wooden jigsaw puzzle
C14242**

- 49 elements, incl 46 puzzles;
- size: 40 x 1 x 30 cm;
- age: 3+





FOUR SEASONS PUZZLES

24 interlocked pieces for each puzzle with different season themes, depicting children enjoying different seasonal activities.

- 24 pcs;
- size: 30,5 x 1 x 22,5 cm;
- made of wood
- age: 3 +



Spring
VG5126



Summer
VG5127



Snail with letters
VG5522

A wooden puzzle with letters (no diacritics).

- 26 elements; size: 18 x 1,8 x 21 cm



Autumn
VG5128



Winter
VG5129



Sets of four-piece theme puzzles for toddlers. The themes including animals and vehicles, vivid colours as well as child-safe shapes inspire manipulative play.

All illustrations and forms are adapted to the age and capabilities of children. Play time with the set's elements encourages learning about the world, it trains

fine motor skills, perceptiveness and imagination. The puzzles are made of thick cardboard.

- 24 pcs., age: 18 months +



**Set of cardboard jigsaw puzzles.
Farm animals**

CI0026

- 6 puzzles: sheep, duck, chicken, horse, cow, pig



**Set of cardboard jigsaw puzzles.
Forest animals**

CI0027

- 6 puzzles: lion, bear, owl, koala, fox, elephant



**Set of cardboard jigsaw puzzles.
Insects**

CI0025

- 6 puzzles: ladybug, snail, bee, earthworm, beetle, butterfly

WOODEN TOPPER



Ocean. Wooden puzzle CI0028

Playtime with colourful elements of the puzzle teaches children to identify different sea animals and geometrical shapes. This toy supports the development of eye-hand coordination and the ability to solve problems.

- 13 pcs: 12 puzzles, 1 base;
- dim.: 30 x 21 x 1,2 cm;
- material: wood; age: 1+;



Forest. Wooden puzzle CI0030

This puzzle helps to learn to recognise various forest animals and geometric shapes. It develops eye-hand coordination and the ability to solve problems.

- 13 pcs: 12 puzzles, 1 base;
- dim.: 30 x 21 x 1,2 cm;
- material: wood; age: 1+;



HANDY BLOCK PUZZLES

Looks simple but brilliant colors & well sanded edges and corners are just right for the little ones. Each puzzle contains 3-5 raised pieces perfect for little hands to manipulate. It is a great introduction to colors, shapes, basic objects and it helps developing finger motor skills.

- size: 15 x 1,8 x 15 cm;
- age: 18 m+;



Ship
VG5017



Teddy Bear
VG5016



Ladybug
VG5015



House
NS0881

• size: 22 x 22 cm



Locomotiv
NS0882

• size: 22 x 22 cm

Wooden knob puzzles. Pastel colours, modern design and shapes suitable for small hands are distinctive features of our new wooden stacking puzzles. The pegs help the child to handle the elements and the wooden board gives clues about target locations and so helps complete the task. All the puzzles differ in pictures, sizes and the numbers and shapes of the elements.

- age: 24 m+



made of varnished plywood



Hedgehog
NS0887

• size: 22 x 22 cm



Butterfly
NS0886

• size: 22 x 30 cm



Turtle
NS0885

• size: 22 x 22 cm



Flower
NS0888

• size: 22 x 30 cm



Ladybug
NS0884

• size: 22 x 22 cm





My Cutting Fruit
VG0978

- 8 fruit halves, knife and a cutting board
- size: 22 x 2,5 x 15 cm; age: 18 m+



3 figures. Puzzle
NS0152

- base size: 30 x 30 cm



Tic-tac
CI3655

Children will learn their colors, numbers, hours and minutes as they play with this multi-activity clock. Helps develop flexibility & fine motor skills.

- ø 22 cm;
- age: 3+

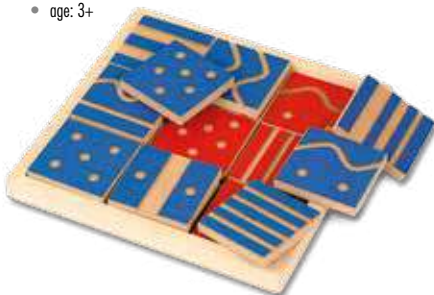

Tactile matching game
NS3043

- base size: 27 x 2,2 x 27 cm;
- each box: 8 x 1,2 x 8 cm



Wooden three-level puzzle. Body in motion
CI0031

Three-level puzzle helps children to learn the secrets of the human's anatomy. Each level presents a different part of the human's anatomy like skeletal system and the muscular system with the internal organs. Among the puzzles there are also tiles with images of children performing various activities. This is aid which will introduce children to the world of anatomy as well as develop eye-hand coordination, logical thinking and fine motor skills.

- 19 pcs: 18 puzzles, 1 base dim.: 30 x 30 x 1,2 cm;
- material: wood; age: 1+

SENSORY GAMES



Touch and match
NS0486

- a set of wooden blocks with different surfaces;
- 20 pcs (10 pairs); size: 9 x 1 x 4,3 cm



Tactile board
NS0522

- size: 23 x 12 cm



Tactile domino
NS0523

- base 33 x 22 cm;
- 28 boxes 9 x 4,3 cm

Maximemo with texture**NS0487**

- in a wooden frame;
- 16 plates;
- size: 15 x 11,4 cm

**Sensory path****NS0488**

A set of tiles with different textures framed with solid wood.

- 6 tiles;
- size: 35,5 x 2 x 30,5 cm

**Panels with textures****NS0894**

- 10 pcs;
- size: 15 x 15 x 1 cm; circle ø 10 cm

SENSORY CUBES



Treasure pockets NS0908

A shelf with four small cloth pouches in different colours for hiding various small objects to be identified by touch.

- size: 68 x 18 x 21 cm



Riddle Owl NS1829

The purpose of the box is hiding the items that children have to guess by only touching them. It's a great fun that develops the sense of touch and enriches vocabulary.

- size: 39 x 21 x 30 cm;
- hole ø 7,5 cm

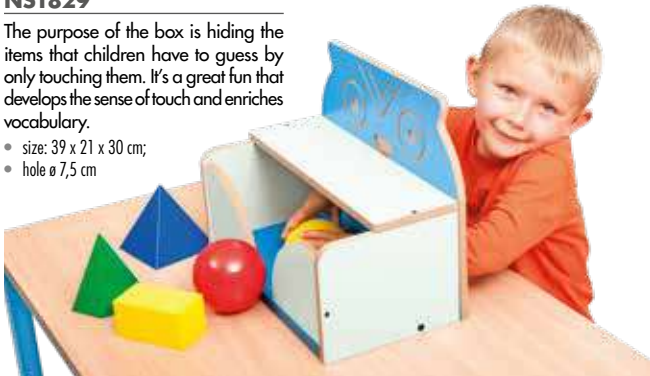

Touch and Guess puzzle box RV1011

Use your hands to touch without watching. Use your sense of touch to guess the object shape and name. Let's touch, let's think, let's guess. You can also have fun by mix and match. One game, much fun.

- 16 wooden shapes;
- box size: 15,5 x 15,5 x 15,5 cm



An educational cube with 4 Plexiglas mirrors in various geometrical shapes. Made of PVC-covered high-density foam. The small mirrors are attention attractors

for toddlers, who love to watch their own reflections and react to their own movements. As well as providing fun, the mirror helps children to increase their

concentration span, discern details, and gradually raise the awareness of oneself as a separate human being. Can also help to learn to speak.



Black&White NS2115

- size: 25 x 25 x 25 cm; age: 1+



Colourful NS2103

- size: 25 x 25 x 25 cm; age: 1+



Texture cube NS2142

A sensory foam cube with different texture walls.

- size: 20 x 20 x 20 cm; 1 pc

SOFT

Manipulative cube
with butterfly pattern

NS0945

- size: 30 x 30 x 30 cm

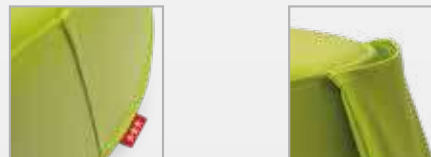

Pocket seat
NS2176

A seat in the shape of a pouf with two pockets on the sides. The pockets have a therapeutic function, allowing the child to calm down and relax.

- dim.: 32 x 30 x 32 cm;
- seat height 32 cm;
- cover: phthalate-free, abrasion-resistant PVC fabric in green, filling: highly resilient polyurethane foam



several layers
of clothing

Tolek
NS2065

- 6 clothing pieces

MANIPULATIVE DOLLS

Large soft dolls dressed in several layers of clothes with different fastenings (wooden and plastic buttons, studs, velcros, zips, laces

and buckles). Playing with the toys, the child develops dexterity and self-reliance.

- H 75 cm



Tola
NS2054

- 4 clothing pieces



Baby
NS2067

A soft doll with a set of garments (8 pcs) with assorted fasteners (Velcro, zipper, lace).

- H 44 cm





Manipulative flower NS2680

Manipulative flower made of soft fabric with many engaging parts, including: clips, buttons, hook and loops fasteners, laces and a slider.

- diameter of 50 cm, height: 10 cm



Treasure candy NS2072

Soft and pleasant to touch candy shaped pillow with manipulation applications for children curious about the world. Cords, buttons, Velcro, buckles, press studs are elements that support the development of motor skills, visual perception and cognitive skills. In addition, it stimulates the child's sense of sight, hearing and touch. Inside the bonbon, we can find sensory accessories of various shapes and textures.

- length: 70 cm, diameter: 70 cm;
- material: micro-fleece, filling: a blend of cotton and polyester fibers; can be washed at 60 degrees C;
- 6 sacks in different shapes and textures with plastic balls filling, dim. around 15 cm, age: 2+



Snail Maze US0498

A soft sensory snail whose shell serves as a maze. Between two layers of fabric there are three small balls to be pushed through the labyrinth using fingers.

- size: 24 cm;
- 3 balls;
- material: velour;
- age: 0+

TAPESTRIES



Carriage
NS1597

- 1 carriage size.: 40 x 23 cm;
- 15 clouds



Calendar
NS1661

This educational tapestry calendar is essential in every classroom. It is large format and has pockets for cards with the names of the months and the days of the week. 6 soft appliques presenting the weather conditions typical of a given season help children observe in which months the seasons change. By buttoning on two

arrows one can show the current month and the day of the week, which is an extra manipulation exercise. The cards with names can be printed out or handwritten during a groupwork activity. Optionally, cards with foreign language names for the days and months can be prepared, which makes the calendar very useful for a foreign language teacher.

- size: 150 x 90 cm

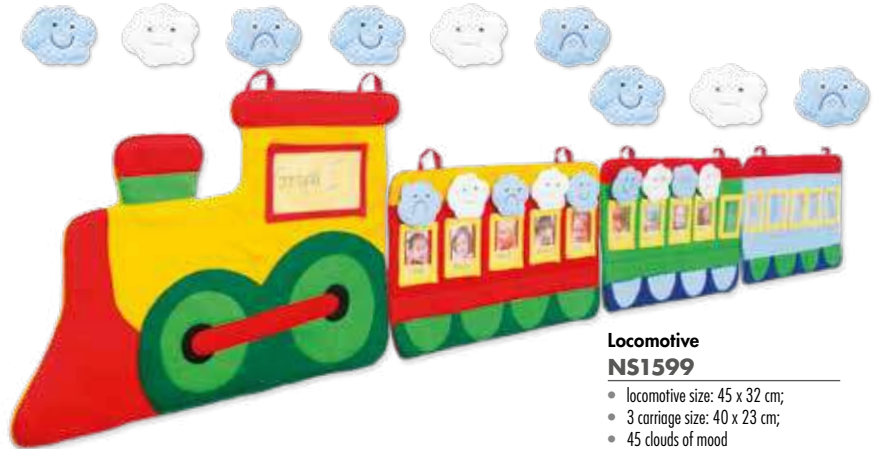

Locomotive
NS1599

- locomotive size: 45 x 32 cm;
- 3 carriage size: 40 x 23 cm;
- 45 clouds of mood



Mat for fruits and vegetables
NS1655

A mat with velcro fastening to illustrate the growth of particular vegetable and fruit.

- size: 100 x 1,0 cm;
- fruits and vegetables sold separately

Mat Fruits and Vegetables Set
NS1652

- mat (100 x 1,0 cm);
- 10 fruits (7 x 15 cm; with velcro);
- 11 vegetables (7 x 15 cm; with velcro)



Vegetables
NS1653

The set includes a beetroot, onion, pumpkin, potato, cucumber, pepper, aubergine, carrot, lettuce, peas and a tomato.

- 11 pcs;
- size: 7 x 15 cm;
- with velcro



Tree Four seasons

NS1660

- size: 130 x 80 cm;
- 39 attachable elements



Apple tree

NS1603

- size: 75 x 70 cm



DALTON'S PLAN

Dalton teaching aids help to enable the implementation of The Dalton Plan pedagogical education technique. Instead of the traditional classroom model, learning takes place through experience and action. The focus is on the individual work of students while the teacher's role is to guide students and meet their various educational needs. The Dalton Plan allows the teacher to adjust the pace of learning to real predispositions of children. It teaches them to rely on themselves, to take action and to think independently. Children develop a sense of responsibility and they are motivated to search for the best and simplest work strategies. When creating the teaching aids for the Dalton Plan technique, the visual aspect is crucial. The visualisation is extremely valuable and effective.



Magnetic Week Planner. Tulips. Dalton Plan.

NS9611

Magnetic board with colourful days of the week in the shape of tulips. It helps children to get acquainted with the concept of the days of the week. Tulips' colours are unique and they

symbolise different days. The attached arrow serves as a pointer. By using it, children can easily mark a given day of the week. Perfect educational aid for the implementation of the Dalton Plan.

- dim. of the board: 74 x 14 cm;
- dimensions of the leaf: 7,3 x 6,9 cm;
- can be fixed on the wall

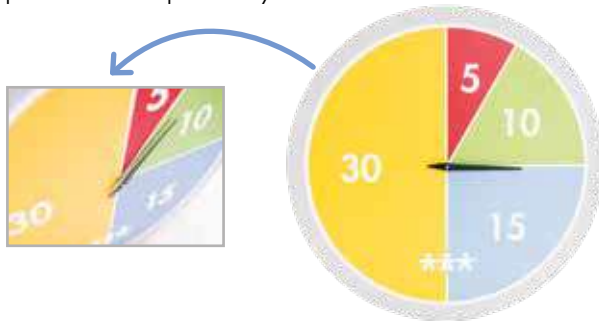

Clock. Dalton Plan NS9600

The clock has a visible clock hand and a dial face with time intervals and corresponding colours. This division is clear, and it makes the clock perfectly suited for use in preschools and schools. It helps to understand the concept of time, the rules of determining it and to plan the work in a given period. Before children start their individual

work, the teacher should specify which colour represents the time they have to complete the task. The hand of the clock should be set manually.

- dim. of the dial: 43 cm;
- time intervals and colours: red – 5 minutes, green – 10 minutes, blue – 15 minutes, yellow – 30 minutes;
- material: MDF boards, 10 mm thick;
- battery powered mechanism: 1,5 V AA;
- age: 3+

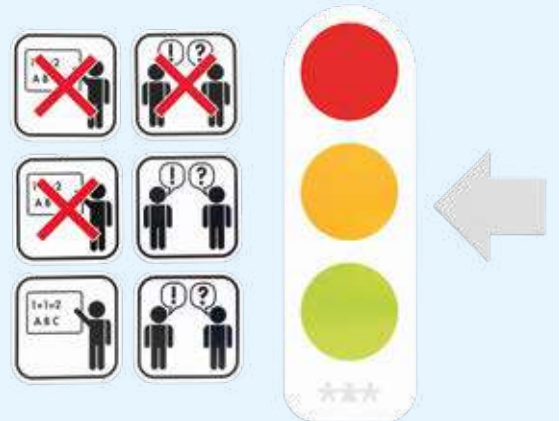

Magnetic traffic lights. Dalton Plan NS9603

Magnetic traffic lights help the teacher in non-verbal communication with children. By using the method of deferred attention, we give children a chance to work individually at their own pace. Only three colours are used to instruct the children.

- red colour - independent work, time to think about a solution;

- yellow colour – children who didn't find a solution can ask their friends for help;
- green colour – children who still didn't find the solution can ask their teacher or a classmate for help;
- in most cases, children are able to solve the assigned tasks alone or with the help of a friend, it teaches them to rely on themselves, to think independently and they are motivated to find the best and simplest solutions;
- dim.: 38 x 12 cm;
- dim. of the pictograph: 10 x 10 cm;
- dim. of the arrow: 10 x 10 cm

MONTESSORI EDUCATION

A rich collection of Montessori teaching aids consists of learning materials intended for work with children in the age group from 2 to 14 years. Respecting the founder's beliefs, all presented products help children to gain knowledge,

competences, skills and experience through spontaneous activity, engaging all their senses. Teaching materials, including mathematical, botanical and geographical cards, have simple and classic shapes thanks to the high-

quality wood. Some of them have plastic elements. Their colours and attractive design encourage children to use them. These teaching aids are divided into several groups corresponding to the areas of child's education in preschool

and school age. They stimulate cognitive activity while meeting the requirements included in the core curriculum. The child using Montessori aids does not learn in a traditional way, but instead learns and discovers knowledge independently.

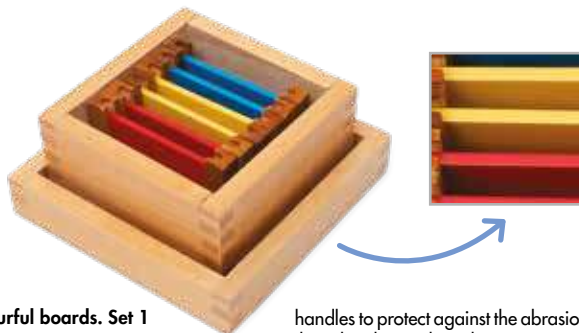

Colourful boards. Set 1 AO2005

Sensory boards for practising the ability to distinguish, identify and name colours. The set contains three pairs of rectangular boards in three primary colours. Along the shorter sides, they are equipped with

handles to protect against the abrasion of the colour by touching them or moving on the surface of e.g. a table. These boards are kept in a wooden box with a lid.

- 6 pcs: 2 x red board; 2 x yellow board; 2 x blue board;
- 7,5 x 5 x 1 cm;
- material: wood;
- meas. of the box: 12,5 x 12,5 x 5,5 cm; age: 3+



Colourful plates. Set 2 AO0003

This Montessori aid is essential in acquiring the ability to distinguish, identify and name primary, secondary and achromatic colours. It also allows the students to experiment with colours – the principle of mixing colours derived from primary colours. The set includes 11 pairs of boards in three primary colours, five secondary colours and three achromatic

colours. The rectangular tiles along the shorter sides are equipped with handles to prevent the colour from rubbing off. All elements of the set are kept in a box with a lid.

- 22 elements: 3 x 2 pairs of boards in primary colours: red, yellow, blue; 5 x 2 pairs of boards in secondary colours: orange, pink, purple, green; green, brown;
- 3 x 2 pairs of boards in achromatic colours: white, grey, black; meas. of the box: 28 x 12,5 x 5,5 cm;
- material: wood; age: 3+



Sensory plates AO2011

The lockable box with two chambers. In the first one, we can find 5 pairs of dark boards of varying roughness degree - from the least to the most rough (5 degrees of roughness). In the other one, there are 5 pairs of light boards - smooth to rough (5 degrees of mild roughness). The act of

identifying and matching surfaces with different degrees of roughness develops and sensitises the sense of touch. This set allows the child to gain experience through the sense of touch.

- 10 boards in 2 colours: brown and green;
- meas. of the board: 14 x 10 x 0,4 cm;
- meas. of the box: 19,5 x 17,5 x 11 cm;
- material: wood; age: 3+



Colourful plates. Set 4 AO2048

Box with a lid and 9 pigeonholes. In each of them, we can find boards in different colours in 7 shades. This set stimulates the sense of sight through the acquisition and training of the ability to distinguish and name colours. It allows the students

to practice arranging colours according to the degree of their saturation (shades), it also develops sensitivity to beauty and colour harmony.

- 63 boards in 9 colours: yellow, orange, red, pink, purple, blue, green, brown, grey;
- meas. of the board with frames: 7,5 x 5 x 1 cm;
- meas. of the box: 27 x 27 x 5 cm;
- material: wood; age: 4+



Pink tower
AO2007

This aid helps to introduce the concepts of: big-bigger-the biggest, small-smaller- the smallest, bigger than ... It also develops motor skills, coordinates movements, shapes the concept of order.

- 10 wooden blocks in pink;
- the size changes three-dimensionally, i.e. the smallest cube is 1 cm wide and the largest 10 cm



Brown stairs
AO2010

Simultaneous change of two dim and weight. Correlation and concepts: thick - thin, thick - thicker - the thickest, thin - thinnest - the thinnest.

- 10 cuboids blocks with a height of 20 cm;
- made of solid brown varnished wood;
- subsequent blocks differ in the size of their base: the smallest 1 x 1 cm, the biggest 10 x 10 cm



Long bars
AO0001

Concepts of the difference in length and size of objects (long - longer - the longest, short - shorter - the shortest).

- 10 red cubic balks of different lengths;
- the length increases by 10 cm (from 10 cm to 1 m) respectively simultaneously with the weight of each balk;
- size.: 25 x 100 x 2,5 cm



Baric tablets
AO2009

Set of 3 boxes with lids, in each box there are 10 wooden boards. The board sets are in different colours and they also differ in weight. The colour of the boards suggests their weight. Dark - heavy, brighter - lighter, brightest - lightest. By using these boards, children not only develop concentration

and muscle-motor coordination, but also acquire and perfect the ability to distinguish the weight with their hands. They are also introduced to the terms related to the concept of weight: heavy - light, gradation of these terms, heavier than ..., lighter than ...

- 30 elements in 3 boxes;
- meas. of the board: 6 x 0,5 x 8 cm;
- meas. of the box: 13 x 13 x 7cm;
- material: wood; age: 3+

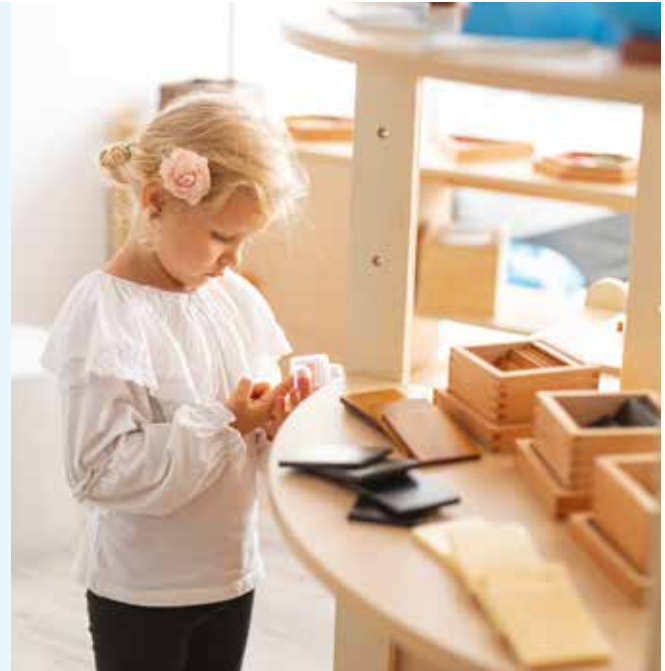

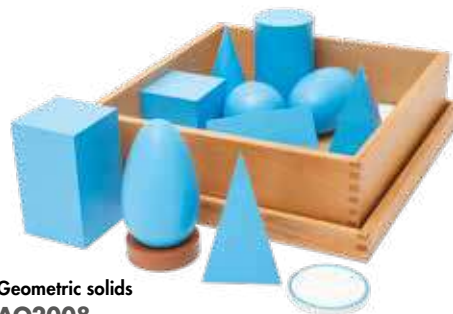

Geometric solids

AO2008

This set of solids introduces children to the world of geometry by teaching them the construction of flat and spatial figures - base and wall. By manipulating objects, distinguishing and naming geometric figures, they develop the sense of sight and touch. The set includes stands facilitating the work with rounded solids. All elements of the set are kept in a box with a lid.

- 18 elements: regular geometric solids: cube, cuboid, prism, pyramid with a triangular base, pyramid with a square base, cone, cylinder, sphere, ellipsoid, ovoid (egg);
- flat figures: circle, square, rectangle, equilateral triangle, isosceles triangle;
- 3 stands; meas. of the box: 30 x 28 x 8 cm;
- material: wood, age: 3+



Geometric cabinet. Cabinet with geometric figures AO2013

Wooden cabinet with 6 drawers storing flat geometric figures. The set introduces children to the world of geometry. There is a space left on the top shelf for a figure demonstration tray (AO2012). Each drawer, with blue-coloured bottom, is filled with wooden frames. In each of them there are geometric figures and yellow square tiles. In the following drawers, the figures are arranged according to the order in which they will appear: I drawer - 6 circles, II drawer - 6 rectangles, III drawer - 6 triangles, IV - 4 quadrangles, V drawer - 6 regular polygons,

VI drawer - rounded figures. Noticing, differentiating, classifying and naming flat geometric figures develops visual perception. Muscle and movement coordination exercises of the hand and wrist train fine motor skills and prepare the hand for learning to write.

- 32 pcs: 6 circles with the dia. of 5 to 10 cm; 6 rectangles, from 5 to 10 cm and from 10 to 10 cm; 6 triangles: acute equilateral, acute triangle isosceles, rectangular isosceles, rectangular polygonal, obtuse isosceles, obtuse polygonal; 4 quadrilaterals: rhombus, parallelogram, isosceles trapezoid, rectangular trapezoid; 6 regular polygons: from pentagon to decagon; 4 rounded figures: ellipsoid, oval, spherical triangle, clover (flower, rosette); meas. of the frame and the blank tile: 14 x 14 x 0,4 cm;
- meas. of the cabinet: 47,5 x 23 x 32,5 cm;
- material: wood; age: 3+

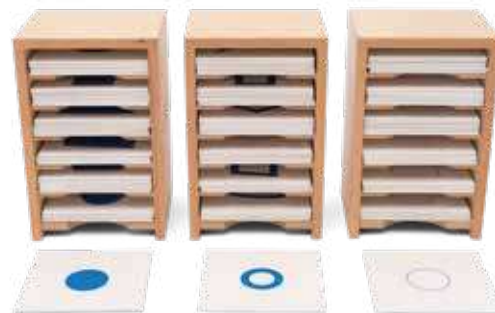

Geometric cabinet. Cabinet with cards with geometric figures AO2014

This set it is part of a geometric study and it consists of three cabinets with six shelves, on which the cards with geometric figures are kept. The first cabinet contains figures filled with colour, cabinet II - figures with a thick outline, III - figures with a thin outline. In each cabinet, on the next shelves from above, are placed the cards: with circles, then with rectangles, with triangles, with quadrilaterals, with polygons, and the last shelf is taken up by rounded figures. The activity with cabinets helps to associate the shape of the figures with their counterparts on the cards. It

stimulates visual perception, consolidates the knowledge of shapes and names of flat geometric figures and improves the ability to define their characteristic features.

- 96 cards, in each cabinet we can find: 6 cards with wheels dia. from 5 to 10 cm; 6 cards with rectangles, sides from 10 x 10 cm to 5 x 10 cm, 6 cards with triangles: acute equilateral, isosceles acute, isosceles rectangular, equilateral rectangular, obtuse isosceles, obtuse polygonal; 4 cards with quadrilaterals: rhombus, parallelogram, isosceles trapezoid, rectangular trapezoid;
- 6 cards with polygons: from pentagon to decagon;
- 4 cards with rounded figures: spherical ellipsoid, oval, spherical triangle, trefoil (flower);
- meas. of the card: 14 x 14 x 0,2 cm;
- meas. of the cabinet: 17 x 26 x 15 cm;
- material: wood; age: 3+



Colourful construction triangles AO2016

Four boxes in which there are coloured triangles for constructing regular and irregular flat figures and patterns. Triangles should be sorted based on their colour or black lines along their sides. The box in the shape of a triangle contains elements which, when assembled according to the rules, form triangles: 1 grey as a whole, green with 2 triangles, yellow with 3 triangles and red with 4 triangles. The box in the shape of a large hexagon contains the parts that make up regular polygons: yellow hexagon consisting of 1 whole, yellow hexagon made of 4 triangles,

grey parallelogram of 2 triangles, red rhombus of 2 triangles. The box in the shape of a smaller hexagon contains elements with the help of which it is possible to arrange regular polygons: 1 yellow triangle from 1 whole, 3 red diamonds consisting of 6 triangles, 1 green isosceles trapezoid made of 3 triangles and 1 grey hexagon made of 6 triangles. Two sets of triangles are placed in a rectangular box. One set consists of yellow, grey, green and red triangles forming regular quadrilaterals: 1 green square, 1 grey rectangle, 1 red trapezoid, 1 yellow rhombus, 1 green and 2 yellow parallelograms. Each quadrilateral is made up of two triangles. The second set consists of

blue triangles without black outlines. From these triangles, regular quadrilaterals are formed, each made of 2 triangles: 1 square, 1 rectangle, 1 rhombus and 1 isosceles trapezoid. The child by acquiring the basics of geometry, develops and improves the ability to construct and name different geometric figures. This activity allows the students to discover that triangles can create regular or irregular shapes and patterns.

- 62 pcs, meas. of the triangular box: 26,5 x 3,5, 23 x 23 cm;
- meas. of the large hexagonal box: 26,5 x 3,5 x 23,5 cm;
- meas. of the small hexagonal box: 25 x 3,5 x 22 cm;
- meas. of the rectangular box: 29,5 x 4 x 22,5 cm;
- material; wood; age: 4+



Blue construction triangles AO2017

This set allows the child to acquire and improve the ability to create geometric figures and patterns from triangles. It also trains visual analysis and synthesis, develops visual perception and hand-eye coordination. The set includes

- 12 rectangular and equilateral triangles in blue, 12 pcs;
- meas. of the triangle: 16 x 14 x 8 cm;
- meas. of the box: 20 x 4 x 14,5 cm; material: wood; age: 3+



Geometric cabinet. Demonstration tray for flat geometrical shapes AO2012

This tray complements the geometric study equipment. It allows the students to acquire the ability to distinguish, identify and name basic geometric figures. It consists of two parts. The lower part is lined with three square tiles in yellow and three yellow frames with three basic geometric figures: circle, square and triangle. The bottom of the tray is blue underneath the tiles and frames. The top of the tray is covered with a frame that dividing it into 6 fields. The back edge of the frame is connected to the tray by hinges. The tray's front is equipped with two fasteners preventing the frame from opening when working with figures.

- 6 tiles: 3 square tiles, 3 frame tiles with figures;
- meas. of the tiles: 14 x 14 x 0,4 cm;
- meas. of the frames: 44,5 x 30,5 x 3 cm; material: wood; age: 3+



Colourful roller AO2015

Set consisting of four boxes with lids. Each box and each lid is marked with a colourful dot, which informs about the colour of the cylinders stored inside. In every box there is a set of cylinders in one colour but in different sizes. Their size (diameter, height) decreases or increases. The first box contains red cylinders – their height is the same but the diameter of the bases decreases. The box nr II: yellow cylinders - their height and base diameter decrease. The box nr III: green cylinders - their height increases and the diameter of the bases decreases. The box nr IV: blue cylinders - the height changes, the diameter of the bases remains the same. This set influences the improvement of the ability to recognise and name differences in dimension. It helps to form the concepts of: big-small, gradation of these terms, bigger than ..., smaller than ..., thick-thin, gradation of these terms, thicker than ..., thinner than ...The boxes have two widths and two heights.

- 40 cylinders in different sizes and 4 colours: yellow, red, green, blue;
- 4 boxes with 30,5 x 8 x 7 cm (blue dot); 38,5 x 10,5 x 7 cm (yellow dot); 38,5 x 10,5 x 7 cm (green dot); 38,5 x 10,5 x 7 cm (red dot);
- material: wood; age: 2,5 +

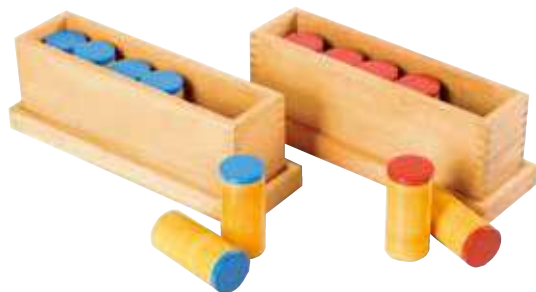

Montessori Aids. Sound cylinders AO0002

The children pair the cylinders (blue and red) making sound with of the same intensity or arrange them in sequence according to the degree of sound intensity. Two boxes containing 6 pairs of wooden cylinders filled with different materials.





Montessori Aids. Block with cylinders 1
AO2001

- increasing height and increasing diameter; 1 pc



Montessori Aids. Block with cylinders 2
AO2002

- constant height and increasing diameter; 1 pc

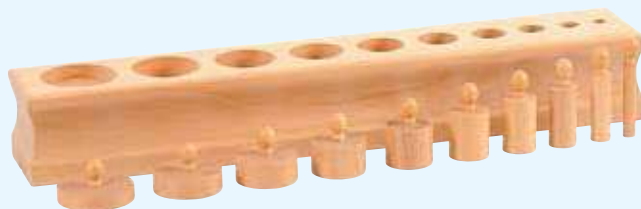

Montessori Aids. Block with cylinders 3
AO2003

- decreasing height and increasing diameter; 1 pc

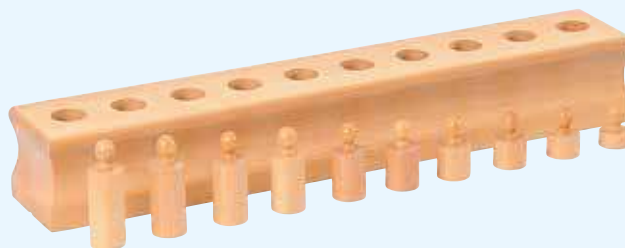

Montessori Aids. Block with cylinders 4
AO2004

- increasing height and constant diameter; 1 pc



Montessori Aids. Aromatic bottles
AO2042

Set of bottles which teaches the child to identify and differentiate smells. They can be filled with any substances.



Montessori Aids. Flavour containers
AO2043

Set of 8 bottles which teaches the child to identify and differentiate flavours.



Crayons mat
AO2045

Wooden mat supporting the child in organizing the space for learning to write and maintaining order. Every mat has enough space for 3 crayons. The material belongs to the metal frames for learning to write and a set of crayons.

- 3 mats with meas. of: 9,5 x 5,5 x 2 cm;
- colour: blue, pink, yellow;
- material: wood; age: 3+



Crayons container
AO2046

Colourful containers in primary, secondary i achromatic colours. They allow the students to properly store crayons and keep the space clean. The material belongs to the metal frames for learning to write. **ATTENTION!** This set does not include crayons.

- 1 containers, H 8,5 cm and diameter: 4,5 cm;
- colour: yellow, red, blue, orange, pink, purple, green, brown, white, grey, black;
- material: wood; age: 3+



Number cards
AO2019

Set of mathematical cards which helps to simply represent numbers using digits in the form of: units (1-9), tens (10 - 90) and the number 100. The activity with wooden panels develops and improves the ability to create three-digit numbers. All elements of the set are kept in a box without a lid.

- 20 pcs: 9 cards with units (1-9) size.: 7 x 5,5 x 0,5 cm,
10 cards with tens (from 10 to 90) size.: 11 x 7 x 0,5 cm,
1 card with the number 100 size.: 17 x 7 x 0,5 cm;
- material: wood;
- meas. of the box: 19 x 12 x 5 cm; age: 6+



Colourful number cards
AO2020

Number cards with colour coding in accordance with the methodology of Montessori mathematical education. They teach to create multi-digit numbers. This set helps to develop awareness of building and writing multi-digit numbers. The aids in the form of wooden plates depict digits in the following colours: green - units, blue - tens, red - hundreds and green - thousands.

- the set of cards is kept in a box without the lid;
- 4 pcs: 1 x units card size.: 7 x 5,5 x 0,5 cm;
1 x tens card size.: 11 x 7 x 0,5 cm,
1 x hundreds card size.: 16,5 x 7 x 0,5 cm,
1 x thousands card size.: 22 x 7 x 0,5 cm;
- meas. of the box: 25 x 10 x 3 cm; age: 5+



Seguin boards. Set no 1
AO2022

Box with a lid in which are kept two plates. Each of them is divided into 5 fields, 4 of which are marked with the number ten. The set includes plates with numbers form 1 to 9 which can slide under the frame of each box to form a number. I plate - forming numbers from 11 to 15; II plate - forming numbers from 16 to 19. The activity with the plates helps to develop and improve the ability to create numbers in the range of the second tens (the so-called "" teens ""). While playing, the child learns about the creation and notation of two-digit numbers and becomes familiar with the concepts of: tens, units (ten and one equals eleven).

- 9 plates with meas. of 7 x 8 x 0,4 cm; 2 plates with meas. of: 46 x 15 x 2 cm;
- meas. of the box: 52,5 x 21,5 x 4,5 cm; material: wood; age: 4+



Seguin boards. Set no 2
AO2023

Box with a lid in which are kept two plates. Each of them is divided into 5 fields, 4 of which are marked with the numbers from 10 to 90. The set includes plates with numbers form 1 to 9 which can slide under the frame of each box to form a number. I plate - forming numbers from 11 to 15; II plate - forming numbers from 16 to 19. The activity with the plates helps to develop and improve the ability to create numbers from 11 to 99. While playing, the child has the opportunity to understand the position of tens in the numerical sequence and the units function in making the tens.

- 9 plates with meas. of: 7 x 8 x 0,4 cm; 2 plates with meas. of: 46 x 15 x 2 cm;
- meas. of the box: 52,5 x 21,5 x 4,5 cm;
- material: wood; age: 4+



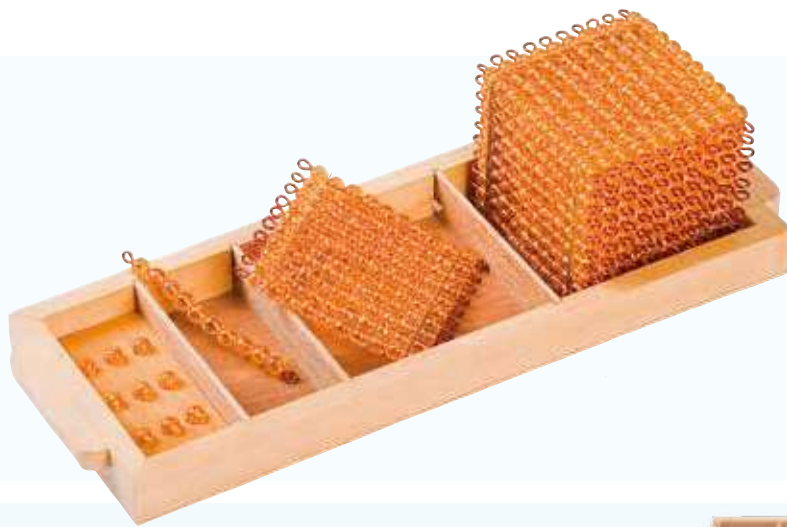

Montessori Aids.
Introduction to decimal system 1
AO0004

The pearl represents units, rod – tens, square – hundreds, cube – thousands. 1 cube, 1 square, 1 rod, 1 single pearl, presentation tray with

- 11,5 x 29,5 x 8,5 cm;
- different dim and weights

Spindles
AO2018

Mathematical aid consisting of 2 wooden boxes without lids. Each box is divided into 5 rectangular pigeonholes and their back walls are marked with numbers from 0 to 9. In each part of the box (except the one marked with zero) there are 45 spindles. They make easier introducing the concept of numbers in the cardinal

aspect, acquire the ability to count from 1 to 9 and remember their order in a sequence of numbers. Additionally, this set develops the ability to associate the number of objects with a digit and it familiarises with the concept of zero as an empty set.

- 45 spindles;
- 16 cm long;
- 2 x box,
- 28 x 3,5 - 7 x 21 cm;
- material: wood; age: 3+



Small set of colourful numbers
AO2021

Kit consisting of two boxes with lids. One of the boxes is divided into 10 pigeonholes. In 9 of them, there are 10 wires with different number and colour of beads symbolising the numbers from 1 to 9. One pigeonhole is empty – it represents 0. The other box contains 24 wires with 10 beads,

the so-called golden tens. The kit teaches the multiplication in the range of 100, introduces the concepts of commutative and separable multiplication. Older students can learn about the exponentiation (square numbers) with the help of this set.

- 114 pcs;
- meas. of the boxes:
28 x 19 x 5cm/16 x 11 x 3 cm;
- material: wood, metal, plastic; age: 3+

Hundreds board

AO2024

This set consists of a framed blue board divided into 100 squares, which correspond to the dim of counting cubes. It also includes a box with two compartments for dices with numbers from 1 to 100. In both compartment there are 50 cubes. The set is complemented by a square control board divided into one hundred fields. Each field is marked with numbers from 1 to 100,

printed in the correct order. The board helps to develop counting skills from 1 to 100, to memorise the numerical sequence in the range of 100 and it allows the students to practice writing numbers from 1 to 100. 100 counting cubes,

- 2 x 2 cm; 1 pcs;
- 1 blue board and 1 control board,
- 29,5 x 4 x 11 cm;
- material: wood;
- age: 3+

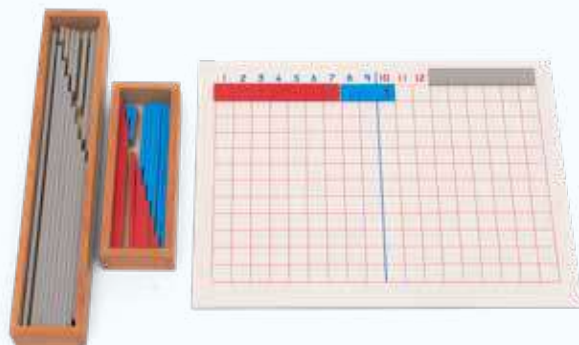

Subtraction Strip board

AO2026

The set includes a board divided into square boxes by blue lines (216). Along the board's upper edge are printed numbers from 1 to 18. The numbers 1-9 are blue and the numbers 10-18 are red. A blue line runs through the centre of the board, right after the number 9, dividing it into two parts. This set also contains a box without a lid, inside of which 2 sets of slats in red and blue can be found. They symbolise the numbers from 1 to 9. The red slats are divided into units by vertical lines. The slats on the right

are marked with numbers. The shortest - 1, the longest - 10. The other box contains grey slats to create a minuend. The shortest one symbolises the number 1, and the longest the number 17. The board allows the students to develop and improve the ability to subtract the numbers in the range from 1 to 18. 36 slats: 18 grey slats,

- 2 x 2 cm (the shortest), 36 x 2 (the longest);
- 9 red slats and 9 blue slats,
- 2 x 2 cm (the shortest), 36 x 2 (the longest);
- 1 board, 40 x 0,5 x 30 cm;
- 1 box for the red and blue slats, 21 x 4 x 7,5 cm;
- 1 box for the grey slats, 39 x 4 x 7 cm;
- material: wood; age: 3+

Addition Strip board

AO2025

The set includes a board divided into square boxes by blue lines (216). Along the board's upper edge are printed numbers from 1 to 18. The numbers 1-9 are red and the numbers 10-18 are blue. A red line runs through the centre of the board, right after the number 10, dividing it into two parts. This set also contains a box without a lid, inside of which 2 sets of slats in red and blue can be found. They symbolise the numbers

from 1 to 9. The red slats are divided into units by vertical lines. The slats on the right are marked with numbers: the shortest - 1, the longest - 9. The board allows the students to develop and improve the ability to add the numbers in the range from 1 to 18 and it also helps to understand the principle of commutative addition.

- 18 slats, 2 x 2 cm (the shortest), 18 x 2 (the longest);
- 1 board, 40 x 0,5 x 30 cm;
- 1 box for the slats, 21 x 4 x 7,5 cm;
- material: wood; age: 5+

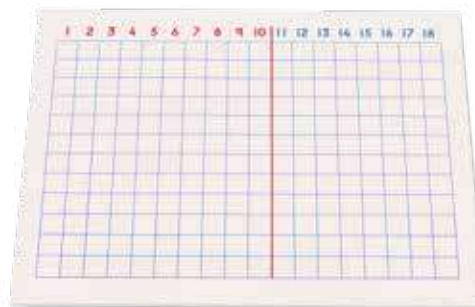

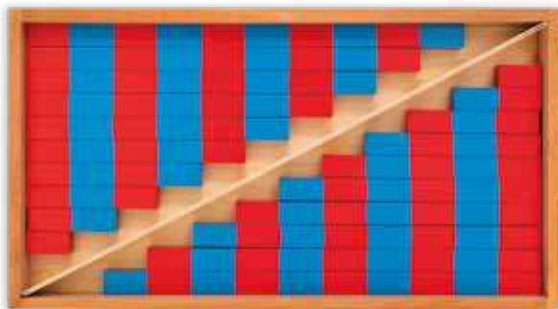

Small double set of counting rods

AO2028

Box with a lid which is divided diagonally into 2 parts. In both pigeonholes of the box there are two sets of counting sticks - ten in each. Red and blue sticks show the numbers from 1 to 10. Odd numbers are red and even numbers blue. Colourful elements make it easier to introduce the concept of number in the cardinal, ordinal, measured and multiplication aspect. It helps to illustrate the meaning of even and odd numbers and also practise performing simple maths operations: addition, subtraction, multiplication, division.

- 20 sticks in red and blue;
meas. of the shortest stick: $3 \times 1,5 \times 1,5$ cm,
of the longest stick: $30 \times 1,5 \times 1,5$ cm;
- meas. of the box: $40 \times 3,5 \times 23$ cm; material: wood; age: 3+

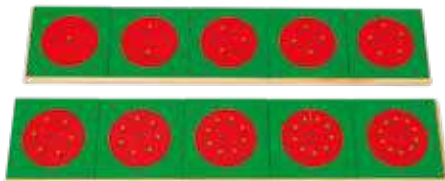

Wooden circles for fractions

AO2027

On two wooden shelves were placed 5 green frames with a circle inside them (10 circles in total). These circles illustrate fractions from whole to tenths. The first circle is a whole, the second is divided into two parts, the next are divided into three, four, five, six, seven, eight, nine and ten parts. This set introduces the concepts of: fraction, proper fraction, improper fraction, mixed number. It also helps to acquire and improve the ability to perform operations on fractions: addition, subtraction, multiplication, division. Additionally, the students can learn the fraction decomposition - the expansion and contraction of fractions.

- 10 green frames, meas: $14 \times 0,6 \times 14$ cm; 10 red circles with the dia. of 10 cm; shelves, $70 \times 3 \times 14,5$ cm; material: wood; age: 6+





Small botanical cabinet. Cabinet with botanical cards

AO2032

This cabinet complements the Small Botanical Study series. It consists of 3 shelves. On each of them is placed a set of 14 cards with leaf shapes. The upper shelf has cards with coloured leaf shapes, the middle shelf with a thick outline and the last shelf with thin outline. The activity with these pieces improves visual perception by matching the shape of the leaves with their image. It also allows the students to practice associating leaf shapes on templates and cards with natural specimens.

- 42 cards in 3 versions depicting leaves: thick outline, thin outline, filled with colour outline;
- meas. of the cards: 14 x 0,3 x 14 cm; meas. of the cabinet: 17 x 15 x 26 cm; material: wood; age: 3+

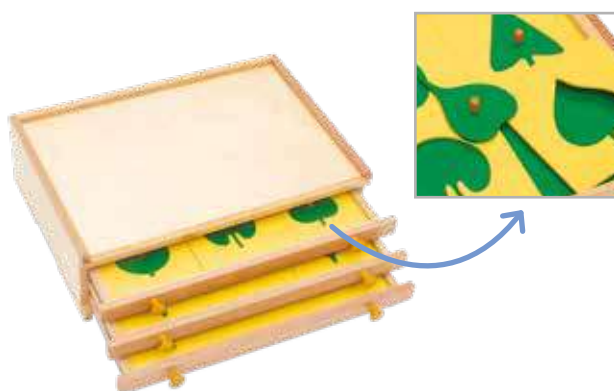

Small botanical cabinet. Cabinet with leaf shapes templates

AO2029

Cabinet with three drawers on which leaf templates are placed. The upper part of the cabinet has space to store control card (AO2030). The first drawer contains 6 frames with 6 templates. The second and the third drawer stores 4 templates and 2 blank plates each. This set allows the students to acquire and improve their ability to recognise, name and associate leaves with the names of their shapes.

- 18 pcs: meas. of the frame with leaf templates and the blank plate: 14 x 0,4 x 14cm;
- meas. of the cabinet: 47,5 x 14 x 32,5 cm; material: wood; age: 5+

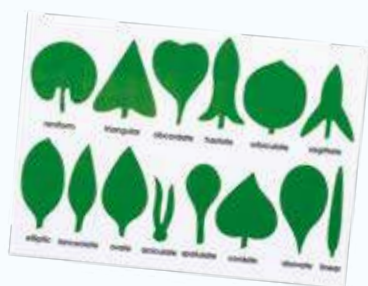

Small botanical cabinet. Leaf shapes names – control cards

AO2030

Control card serves as an addition to the series of botanical study aids. It helps to supervise the proper recognition of the shapes of leaves placed in a botanical cabinet, on botanical cards and cards „shapes of leaves“. It contains 14 leaf drawings with descriptions and shapes: kidney-shaped, triangular, obcordate, spear-shaped, round, sagittate, elliptical, lanceolate, ovate, acicular, spatulate, heart-shaped, obovate, ensiform.

- size: 45 x 31 cm; material: laminated cardboard



Small botanical cabinet. Leaf shapes cards. Educational game

AO2031

Educational game which develops the ability to identify (pair matching) leaf shapes and learn their names. It allows the students to practice global reading by associating a caption with a leaf shape on a card. It contains 2 set of elements, 14 cards each. One set consists of leaf pictures with captions defining their shape. The second one contains only cards with a graphic image of leaves and a separate description of their shapes. All the set's elements are kept in a plastic envelope.

- 8 x 10 cm; 14 cards without descriptions, 8 x 8 cm; captions: kidney-shaped, triangular, obcordate, spear-shaped, round, sagittate, elliptical, lanceolate, ovate, acicular, spatulate, heart-shaped, obovate, ensiform, 8 x 2,5 cm; meas. of the envelope: 19 x 15 cm; material: laminated cardboard, plastic; age: 5+



Botanical puzzle AO0007

Thanks to them the child discovers the world of plants: the structure of the leaf, flower and tree. Each piece can be taken out and put together just like traditional puzzles.

- 3 wooden boards; size: 25 x 25 cm



Fish puzzle
AO2033

- 8 pcs;
- meas. of the frame: 24 x 24 cm;
- material: wood; age: 3+



Frog puzzle
AO2034

- 6 pcs;
- meas. of the frame: 24 x 24 cm;
- material: wood; age: 3+



Turtle puzzle
AO2035

- 6 pcs;
- meas. of the frame: 24 x 24 cm;
- material: wood; age: 3+



Bird puzzle
AO2036

- 5 pcs;
- meas. of the frame: 24 x 24 cm;
- material: wood; age: 3+



Horse puzzle
AO2037

- 7 pcs;
- meas. of the frame: 24 x 24 cm;
- material: wood; age: 3+



Snail puzzle
AO2038

- 8 pcs;
- meas. of the frame: 24 x 24 cm;
- material: wood; age: 3+



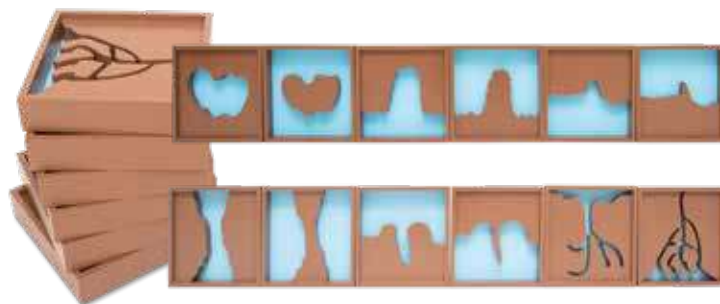
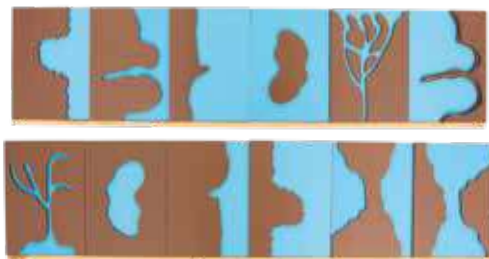

Boards for the landforms AO2039

Set of boards which present landforms corresponding with the forms in the frames. The land is marked with brown colour and the water with blue colour. This set allows the students to acquire the ability to associate the

shape of land and water surfaces with their names. It also improves pair matching efficiency: island - lake, cape - bay, neck of land - bay, peninsula - bay (fjord), isthmus - strait, delta - river.

- 12 boards;
- 14 x 10 cm; 2 x shelf,
- dim.: 60 x 3 x 15 cm; material: wood; age: 5+

Landforms AO2040

An excellent help for practical exercises. It helps to learn about different geological features and their names through experiments with water. The child can memorise the names of

landforms by pair matching. This set contains three-dimensional forms of land which can be filled with water.

- 12 forms;
- dim.: 20 x 4,5 x 20 cm;
- wood;
- age: 5+



MONTESSORI AIDS. EXERCISE FRAME

Wooden frames covered with fabric, equipped with elements which allow the child to practice fastening and lacing. It gives the child an opportunity to practice everyday skills needed while dressing. Playtime with the frame helps to master the skills of buttoning, zipping up and fastening buckles, which also develop motor skills and improve coordination of movements.

- size.: 31 x 2 x 31 cm
- material: beech wood, cotton, metal, Velcro, plastic;
- age: 3+

Wooden frames may be changed



- for lacing
AO0009

- pattern can change



- with large buttons
AO0010

- pattern can change



- with a zipper
AO0011

- pattern can change



- with buckles
AO0012

- pattern can change





- with press-studs
AO1142

- 5 press-studys



- with ribbons
AO1143

- 5 ribbons



- with clasps
AO1145

- 5 hidden clasps



- with safety pins
AO1147

- 6 metal safety pins



- with latches
AO1148

- 4 latches



- with Velcro
AO1149

- 3 Velcro





Puzzle map of the world. Continents. Two hemispheres

AO2041

The map of the world in the form of puzzles helps to enrich the geographical knowledge concerning the continents, their names and location on the globe. It consists of a frame with 2 circles representing the hemispheres - Western and Eastern. On each of them, we can see 7 continents properly distributed.

- 9 pcs; meas. of the frame: 29 x 2 x 40 cm; material: wood; age: 5+



The puzzle map of Europe

AO6011

Map presenting Europe with countries marked with colours. Through play, the child discovers the location of countries.



Flags of the European countries

AO2044

The set of flags of selected European countries. Each symbol of a given country is made of a silky material placed on a wooden shaft, with a smooth, aesthetic cap. This set consists of a base with spaces for 23 flags and of two round bases used during the individual presentation of flags. When combined with a map, this set facilitates learning about chosen countries.

- 23 flags, meas. of the pennant: 14 x 10 cm, shaft with the length of: 27,5 cm; 1 base for the flags,
- dim.: 51 x 8,5 x 3 cm; 2 round bases with the dia. of: 7 cm; material: silk, wood; age: 4+



The Land and Water Globe

AO6001

Water is marked with blue and its surface is smooth while the land is made of rough material. Through tactile experiences and visual perception, children learn that the Earth is spherical, and that there is water and land on it. The globe is removable and children can rotate it in their hands.



Globe with continents

AO6002

The continents are marked with different colours while the waters with blue colour. The child learns the name and size of every continent. The globe is removable and the child can rotate it in their hands.

- dim.: 54, ø 24 cm

EMOTIONS

Through realizing and recognizing their emotions, children can understand and handle their reactions more easily, as well as developing their communicative skills. The section Emotions is a collection of all those of our products which refer to emotions and moods. It

comprises hand puppets, balls, chore charts, poufs, stencils or stamps. Each product shows 6 emoticons symbolizing joy, sadness, fear, anger, surprise and lack of emotion. Each emotion is allocated its own distinctive colour for easier identification.



Balls Emotions LG0613

- 6 pcs; ø 15 cm



Emotions. Sensory bags in sack NS2070

A set of round plastic-filled bean bags embroidered with smiley faces illustrating basic emotions. Made of durable nice-to-the-touch fabric in

pronounced colours. Each emotion is represented by a different colour.

- 6 elements: yellow bag - joy, orange - indifference, violet - surprise, blue - sadness, green - fear, red - anger
- size: 12,5 cm; filling: plastic pellets
- drawstring sack size.: 19 x 22 cm



Dice with pockets NS1887

- A PVC-covered foam cube;
- size: 20 x 20 x 20 cm;
- transparent pocket on each side



Worksheets for NS1887 NS1886W

4 sets of 6 cards featuring emotions, colours, fractions, dice dots and fitting the pockets of the cube.

- 24 pcs; size: 11,5 x 11,5 cm



Stamps Emotions DN2634

- 6 pcs; size: 6,5 x 7 cm



THERAPEUTIC DOLLS

Big educational glove puppet 75 cm high. It is made of soft fabric. The head, mouth and hands can be moved by the hands of the person who manipulates the puppet. Perfect for diversifying the process of learning and as a play companion.



Maggie
NS2681

Brian
NS2682



The power of expression. Wheel of fortune VG4633

An interactive wheel which shows 12 images of children in different poses and with various emotions on their faces. The children's task is to spin the wheel, name the emotion and mimic it.

- dim.: 56,5 x 45 x 6,5 cm;
- material: wood;
- age: 18 months +



Stencils Emotions NS0914

- 6 pcs;
- size: 15 x 15 cm





Emotional puppets

NS2034

Through operating hand puppets and staging plays children get to know the world of emotions, which helps them to understand other people's emotions. Expressing one's own emotions with the

help of hand puppets helps overcome shyness and communication barriers. All the puppets are made of soft fabric with plush elements and they sit firmly on small hands.

- happy, sad, frightened, angry, neutral, surprised;
- 6 pcs; size: 25 cm



Educational puppets Emotions

NS2035

- 6 pcs, size: 25 x 22 cm;
- they teach young children to recognize and express emotions;
- the six facial expressions help develop empathy





Emotions. Round carpet. NS1106

A round carpet with image of faces featuring emotions which helps develop social skills.

- D 200 cm;
- material: loop boucle;
- easy-to-clean non-slip latex bottom, overlock finishing



Emotions seats NS2897

- foam filling, PVC cover;
- ø 32 cm, H 3 cm;
- 6 pieces (each featuring a different emotion)



Emotions. Set of carpet mats NS1107

A set of educational mats for teaching children to recognize, understand and name emotions.

- 6 mats; size: 50 x 50 cm;
- material: 100% polyester, non-slip latex bottom;
- overlock finishing



Relaxing sensory hand squeezers RV0060

Set of hand squeezers filled with liquid containing coloured glitter. The toy's surface is smooth and slick which makes it challenging to keep in hand. These relaxing and manipulative hand squeezers train hand motor skills, stimulate creativity, relax, and help to calm down. Perfect for rehabilitation or SI therapy.

- 4 pcs; dim.: 12,5 x 3 x 3 cm; age: 3+



Relaxing hand squeezers UT0027

Relaxing hand squeezer provides many sensory experiences. It is made of flexible and resilient material which is durable and easy to squeeze. Soft, textured shapes

are not only nice to touch, but they also help children to calm down and relax. Additionally, hand squeezers strengthen the hand muscles.

- 4 pcs: ball, heart, star, oval;
- dim.: 5,8 cm;
- material: thermoplastic polyester elastomer;
- age: 1+



Anti-stress gel squeeze toy UT0042

Relaxing squeeze toy filled with colourful liquids. When pressed, the two-colour liquid is mixed, and it creates a noticeable visual effect. The product's texture is nice to touch while the soft, gel filling is soothing and calming.

- material: PCV;
- dim.: 22 x 15 cm;
- age: 3+



Therapeutic teethers. Classroom set JN0026

Teethers in the shape of a circle, made of safe and non-toxic material are an effective solution for gentle teething. They are also useful as part of speech therapy prophylaxis. Teethers facilitate the exercises connected to chewing and they can replace the habit of sucking the thumb. Their texture significantly increases the sensory experience by stimulating the child's sensorimotor and proprioceptive system. The construction of the set elements gives a chance to form a chain of any length that can be attached somewhere or hung.

- 144 pcs;
- dim.: 7,3 x 4 cm;
- material: plastic; packaging: plastic bag;
- age: 18 months +



Anti-stress ball RV0036

Relaxing squeeze toy filled with colourful liquids. When pressed, the two-colour liquid is mixed, and it creates a noticeable visual effect. The product's texture is nice to touch while the soft, gel filling is soothing and calming.

- material: PCV; dim.: 22 x 15 cm. age: 3+



Anger release punchbag NS2268

A punchbag is great fun and a therapeutic tool for relieving stress and venting energy in hyperactive children and anger in disordered children. Any activity with a punchbag should be supervised by an adult for the safety of the child and so as to prevent any damage.

- size: 26 x 45 cm;
- material: PVC cover with face overprint;
- filling: foam; age: 3+



Anger release mat NS2269

A mat is an excellent tool for learning to control one's negative emotions like anger or rage. A simple way to relieve the feelings is through movement. When emotions are running high, a child can get rid of negative energy by stamping their feet or jumping up and down.

- size: 45 x 45 cm;
- material: PVC cover with feet overprint;
- colour: red, grey; age: 3+

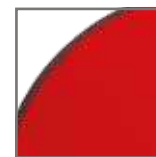

non-slip surface



Time for English

Time for English is a set of educational materials for teaching English to 3-8 year old children. Its innovative character is provided by its unique combination of specially selected 'language teaching tools' such as multi-sensory toys, educational aids, audio materials, and songs with sets of instructions for teachers to guide them through the process of organizing lively, game-packed and involving English language teaching activities. The educational aids and audio materials have been specially designed to provide a rich variety of tasks built

around selected topics, selected vocabulary and associated structures. This approach ensures the compatibility of all of the materials and guarantees great results: the children play, are fully involved in activities, respond spontaneously AND learn English at the same time. The whole set contains over 120 games and activities making use of the Time for English educational aids.

The Time for English set has been tested in preschools and early year primary school and has been proven to be very successful with groups of different sizes.



An example of the topic

FRUIT

The following materials illustrate the compatibility of educational aids to teach children: the English names of fruit, colours, numbers, English instructions to make a fruit salad, fruit art projects connected with printing and English songs which consolidate all of the presented language.

Fruit Salad
Take an apple, take an apple
Take an orange, take an orange

Blueberries, blueberries
Add them too
It's a salad, it's a salad
For me and you

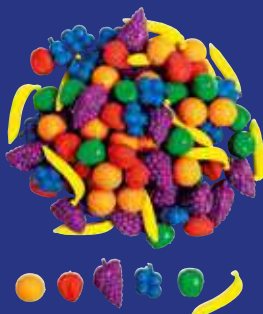

fruit-shaped
counters

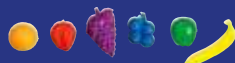

cube with
fruit flashcards



set of instructions
for english classes



fruit stamps



time for english – stall

NS4404

- 73 x 40 x 1,0 cm
- without contents

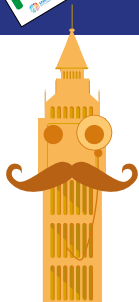

time for english complete set

NS4412

Start Up + Main Course + Time for English Stall



START UP

NS4410

getting the course started

The Start Up Set aims to illustrate the approach and to start teachers teaching! It shows how each of the teaching aids is accompanied by clear and easy to implement instructions for games and group tasks, as well as containing 10 ready to use lessons which TEACH HOW TO TEACH.

TIME FOR ENGLISH START UP contains:

- ◆ 10 lesson plans
- ◆ Instructions for 42 games and activities
- ◆ Fruit-shaped counters
- ◆ A fruit poster
- ◆ A large educational cube with pockets
- ◆ Flashcards to fit the Cube pockets
- ◆ 2 sets of fruit stamps
- ◆ 2 large coloured ink pads
- ◆ Songs will be available on the website
- ◆ A 'Time for English' lolly
- ◆ Cardboard folder with lesson plans and instructions
- ◆ All the products are supplied in a large cardboard box with lid.

Topics:

Greetings and introductions

Numbers

Colours

Fruit

Movement verbs

Shapes

Developing children's dexterity, cognitive skills and English language skills.

Teaching English through multi-sensory activities, movement, games and songs. No textbooks!



Instructions for English language lessons

- ◆ focus on language aims
- ◆ contain a rich variety of language tasks
- ◆ teach speaking through games and movement activities (the TPR approach)
- ◆ provide ready-made lesson plans for teachers

Instructions for educational aids

- ◆ contain 42 games and activities (six for each aid)
- ◆ provide teachers and learners with opportunities to play games in-between lessons

Sets of flashcards for the cube



movement activities

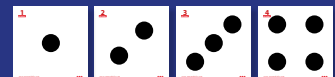

counting



colours and shapes



fruit

'Time for English' lolly

Serves as a signal to begin English language classes

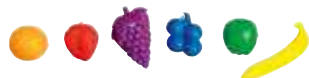

Fruit-shaped counters



Cube with pockets

versatile thanks to its pockets which have exchangeable flashcards



Fruit stamps



MAIN COURSE

NS4411

A follow-up to the Start Up and the main part of the course

TIME FOR ENGLISH MAIN COURSE contains:

- ◆ 20 lesson plans (continued from the Start Up)
- ◆ Instructions for 80 games and activities
- ◆ Animal-shaped counters
- ◆ 18 large flashcards
- ◆ Morphun blocks – animals
- ◆ Zoo beads
- ◆ Game: Dressing the Cats
- ◆ Set of flashcards for the Cube
- ◆ Story cards: daily routines
- ◆ Wooden puppets: family members (2 sets)



Instructions,
lesson plans



- ◆ Felt puppets: emotions
- ◆ Stamps: toys (2 sets)
- ◆ Songs will be available on the website
- ◆ Cardboard folder with instructions and lesson plans
- ◆ All the products are supplied in a large cardboard box with lid.

Wooden puppets: family members

The wooden puppets can be decorated and become family members speaking English. It's a fun activity combining art tasks with drama and English language teaching.



Zoo beads

Children love them and they are motivated to learn the names of zoo animals, their colours and numbers. The multitude of animals in the set helps to keep all the children of all sizes of group engaged.



Animal-shaped counters

72 of these little farm animals can be named, touched, hidden in the palms of little hands, counted, grouped into sets, and used for constructing farms. All of these activities are performed in English and for the purpose of learning English.

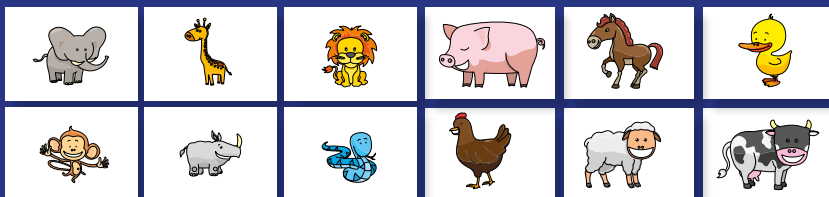

Large flashcards for the topics: farm animals, safari animals, clothes

Flashcards are a basic tool for teaching English to children. The large colourful pictures help the children to remember the words and to introduce English vocabulary using only English.



Flashcards for the Cube

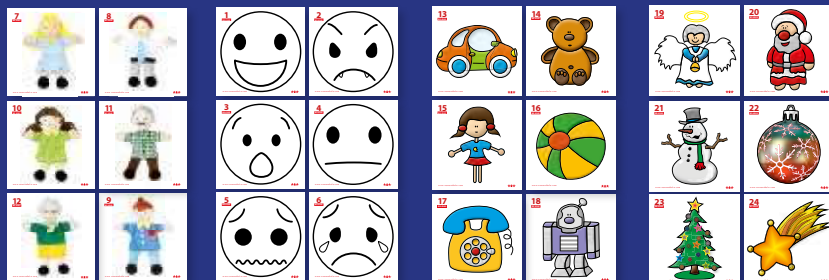

family members

emotions

toys

Christmas



Stamps: toys



Puppets: emotions

Puppets create opportunities for developing children's emotional intelligence and using drama for learning new English words

Topics:
 emotions
 farm animals
 safari animals
 clothes
 family members
 toys
 Christmas



Game:
Dressing the Cats

This is a game that children also like to play with in their free time. The little wheel of chance introduces an element of chance, luck and surprise, which helps to keep the children focused on the task and teaches them English words.



Story cards:
daily routines

The sets of cards create opportunities for sequencing, constructing stories, naming in English and acting out daily activities.



Morphun blocks 3D

Morphun blocks provide opportunities for creating sequences, rhythms, word groups and longer expressions.

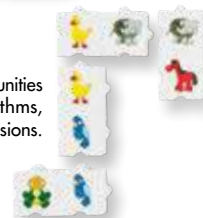



GAMES

Fairy tale stories. Worksheets NS2970

The set contains 48 cards with characteristic symbols from various fairy-tales and stories. Cardboard cards (11,5x8 cm) with rounded corners in a cardboard box. Generally, the cards are meant to be arranged so as to construct a logical story. The set contains 48 cards with imagery referring to widely known European fairy tales. Flashcard activities may be enhanced by introducing hand puppets and/or musical instruments. Children can work individually, in pairs or in a group.

Suggested uses:

- an adult tells a story contained in a set of pictures. The child listens and then, looking at the same set, tries to repeat as many details as possible;
- a child draws three cards and tells the stories which they represent; the difficulty should be graded with more cards added; to add variety to the game, multisensual elements can be introduced (hand-puppets, musical instruments);
- a child draws five cards and tells its own story; the number of cards should be adjusted to the child's

abilities; multisensual elements can be introduced (hand-puppets, musical instruments);

- version for a group: the first child draws a card, chooses one musical instrument, starts to tell a story and play. The subsequent players draw their cards and continue the story, repeating the story so far. They also have to reconstruct the sounds played by the first child.

The activities suggested can be adjusted to the needs, age, abilities or the number of players by modifying the rules as necessary.

Before starting the game all cards should be laid out on the table so as to familiarize them with the symbolic meanings of the pictures and check their knowledge of the fairy tales.

Flashcards for developing language skills:

- help develop logical thinking, and causal reasoning;
- help develop descriptive and narrative skills;
- very useful in introducing, practising and consolidating new vocabulary;
- develop creativity and artistic expression;
- 64 cards with rounded corners in a cardboard box;
- size: 11,5 x 8 cm;
- age: 3+



64 cards

Example Fairytale: Snow White

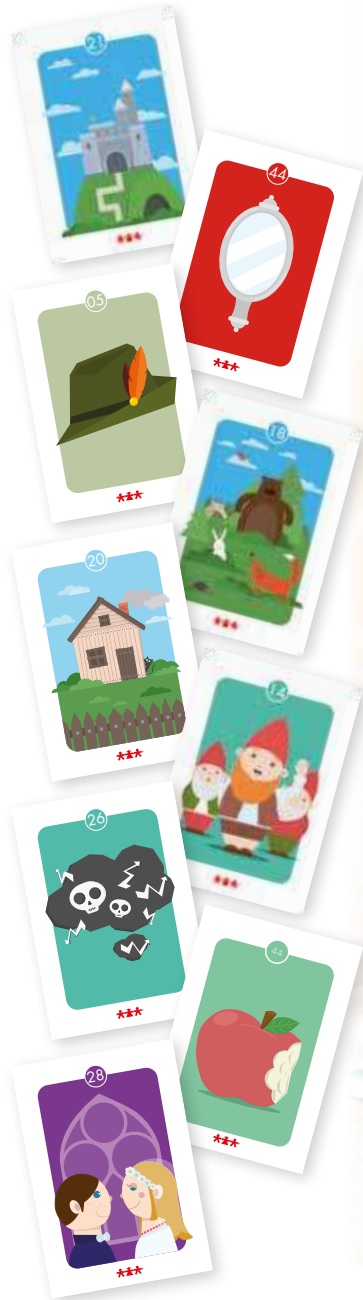



Everyday items – worksheets
NS4214

- 24 pcs: everyday objects;
- meas. 11 x 11 cm;
- packaging: cardboard box



Toys – worksheets
NS4215

- 24 pcs: toys;
- meas. 11 x 11 cm;
- packaging: cardboard box



Household items – worksheets
NS4216

- 24 pcs: household items;
- meas. 11 x 11 cm;
- packaging: cardboard box





Class rules
NS1361

- 35 magnetic cards showing preschool life situations



Safe vs Unsafe Behaviour. Worksheets
NS0306

Pictures presenting safe vs dangerous behaviour.

- 24 pcs (12 pairs) in a box;
- size: 11,5 x 11,5 cm



Good vs Bad Behaviour. Worksheets
NS0305

Pictures presenting appropriate vs inappropriate behaviour.

- 24 pcs (12 pairs) in a box;
- size: 11,5 x 11,5 cm



Clothes. Worksheets
NS4212

- 24 pcs (12 pairs) in a box; size: 11,5 x 11,5 cm



Food. Worksheets
NS4211

- 24 pcs (12 pairs) in a box; size: 11,5 x 11,5 cm



Fruits and Vegetables. Worksheets
NS4213

- 24 pcs (12 pairs) in a box; size: 11,5 x 11,5 cm

MATH AIDS

COUNTING & SORTING



Long counting sticks. Classroom set
JN0018

Counting sticks can be very useful, especially for those children who are just starting their adventure with mathematics. However, they also work well during many other games e.g., sorting and arranging rhythms. The set is suitable for group work.

- 300 pcs; length: 12,8 cm; colour: purple, light green, brown, light blue, light pink, yellow, blue, black, white, pink, green, orange, navy blue, red;
- material: plastic; packaging: plastic bag; age: 3+



Sound cups. Sorting
JN1063

The set consists of transparent cups with lids and colourful elements locked inside. Perfect for learning to sort objects and for making sounds with beads. Play time with this set develops the ability to think logically, to compare elements of different sizes and it stimulates the senses of sight, touch and hearing. Lids have knobs which make opening them easier. These containers can be stacked on top of each other.

- 18 cups with a diameter of 4,5 cm, height: 5,8 cm; beads in different 3 sizes in colours such as: blue, yellow, red, green, orange, purple;
- material: plastic; packaging: plastic bag; age: 3+



Counting cubes. Classroom set
JN0046

Colourful cubes which can help with counting and performing simple arithmetic operations. These cubes can be also used to practice sorting by colour and rhythm building. They improve perceptiveness and logical thinking. Additionally, it is easier for children to manipulate cubes than cards.

- 1000 pcs in 10 colours; meas. 1 x 1 x 1 cm;
- material: plastic; packaging: plastic bag; age: 3+



Sensory gel flower with beads for sorting
UT0045

Gel flower filled with a liquid and beads in different colours. It stimulates the nerves of the hand and develops sensitivity to stimuli. The flower can also serve as an aid in learning about colours and learning to count.

- material: PVC. dim.: 19 x 11,5 cm; age: 3+



Transparent blocks with beads
JN0084

Transparent blocks with beads in 6 shapes and 5 colours. When shaken, the toy rattles.

- 40 pcs;
- dim.: height of the largest block - 10 cm
- age: 18 months+



Transparent maths cubes
JN0021

- dices made of a durable semi-transparent plastic; perfect for learning to count, sort and create patterns; dim.: 2 cm; age: 3+

The light panel is a universal tool which offers a wide variety of possibilities. It provides a soft backlight perfect for experiments with different colours and shapes of objects. Transparent figures, coloured foils, transparent papers and mirrors can be placed on the panel. The panel is made of high-quality materials and it's easy to use. The device is light, durable and safe for children.

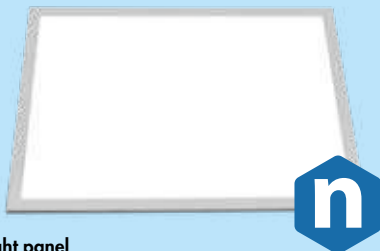

Light panel JN0019

- dim.: 47 x 35 cm; size of the illuminated panel: A3 format. age: 3+



Big light panel JN0020

- dim.: 65 x 47 cm; backlit plate area: A2 (58,5 x 41 cm);
- power cord included



Transparent tray for the light board JN0009

A transparent tray with holders for a light panel. It is designed for sorting and arranging small elements to experiment with colours and light.

- dim.: 38,5 x 2 x 28,5 cm; material: transparent plastic; age: 18 months +



Transparent double dices. Set of 12 JN0112

Each dice has a smaller dice trapped inside. Thanks to the transparent material, smaller dices are clearly visible. They are designed as an aid in mathematical exercises, games and probability theory calculations.

- set includes: 12 dices – dim.: 3 x 3 cm;
- material: transparent plastic



Furniture for the light board JN0120

- 60 pcs in 10 shapes and in 6 colours: a chair, a table, a bed, a TV, a couch, kitchen furniture, a fridge, a TV cabinet, a wardrobe, a dressing table.
- height approx.: 4 cm;
- material: transparent plastic; age: 3+



Cars for the light board JN0124

- 72 pcs. in 6 shapes and 6 colours.
- dim.: length 4,3 cm;
- material: transparent plastic; age: 3+



Light board spinners
JN0140

- 36 pcs; dim.: height 4 cm
- material: transparent plastic; age: 3+



Transparent butterflies
JN0088

Transparent insects help children to study the properties of colour and light. It is a great aid in developing the ability to count, sort and create sequences. When combined with the illuminated panel, they provide amazing visual sensations. The set is delivered in a plastic box.

- 120 pcs, 4 types of insects: ladybug, bee, dragonfly, butterfly;
- 6 colours; dim. of the packaging: 16 x 6 x 16 cm; age: 3+



n

Set of transparent boxes
JN0012

A set of transparent snap-in boxes with handles for storing photos, card games, small pictures and elements like stickers, stamps, or trinkets. Each box can store up to 100 photos. Small boxes are kept in a larger one.

- 16 smaller boxes: 17 x 3 x 12 cm;
- 1 main box: 39 x 12,5 x 30,5 cm;
- material: transparent plastic; age: 3+



Binoculars. Big transparent blocks
JN0050

- 48 pcs;
- dim.: 14,5 x 6 x 6 cm; material: transparent plastic;
- age: 18 months +

n



Transparent jewels
JN0087

Big set of colourful counters in amazing shapes and colors. Perfect for math and logic exercises, as well as sorting and finding rhythms. It also assures unforgettable visual experience when combined with the light panel.

- 240 pcs; meas. 2,5 x 1,8 cm;
- colour: red, yellow, blue, purple, green;
- material: plastic; packaging: plastic bag; age: 3+

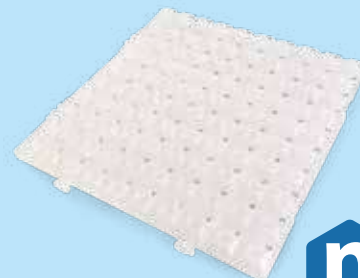

n

Transparent multiplication table
JN0085

A board with a print of numbers from 1 to 10, designed for multiplication exercises with the use of blocks and a light board.

- dim.: 20 x 20 cm
- material: plastic
- age: 3+

Maxi maths. Kit of transparent counting sticks JN1060

- the set includes:
78 squares with letters,
72 crystals,
72 rings,
36 geometric beads,
36 geometric shapes,
10 numbers,
6 boards;
- perfect for learning colours,
shapes, numbers, sorting and
mathematics;
- age: 3+



MATH COUNTERS



Transparent counters

EI0192

- 1000 pcs (4 colours);
- in transparent pot



Geometric blocks

TY1100

- 72 pcs (6 shapes in 6 colours)



Buttons

NS4025

- 75 buttons, 15 connectors, 12 strings;
- 102 pcs



Wild animals

TY6082

- 120 pcs (10 shapes, 4 colours);
- size of one piece: 1,3 x 2 cm



Bear family

MC1145

- 96 pcs (3 sizes in 4 colours)



Animals

LR0180

- 72 pcs (6 animals in 6 colours)

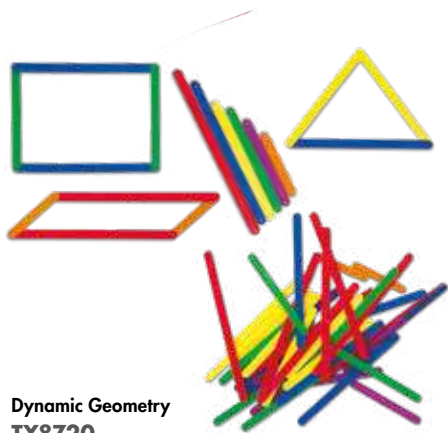

Dynamic Geometry
TY8720

- 72 pcs;
- 6 colours; 6 different lengths

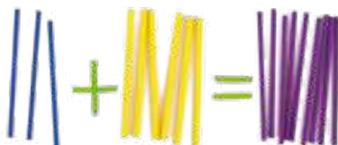

Long sticks for counting
TY7210

- 1000 pcs; L 10 cm; 10 colours

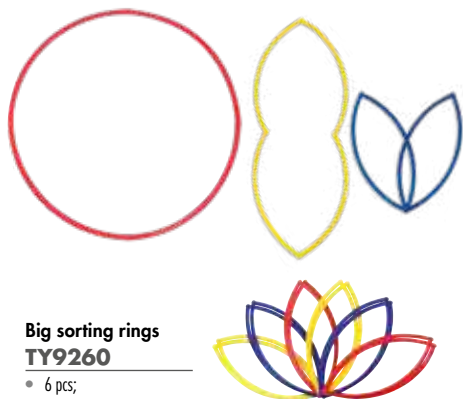

Big sorting rings
TY9260

- 6 pcs;
- ø 52 cm



Big counting Links
TY6336

- 200 pcs;
- size: 5 x 7 cm

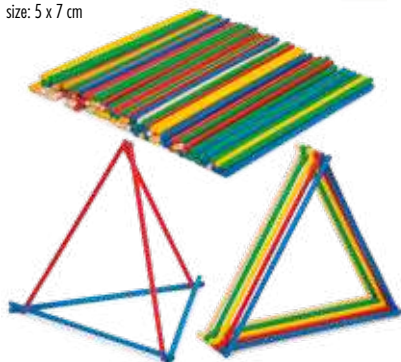

Wooden magnetic rods
NS0390

- ø 0,8 cm; L 30 cm;
- 100 pcs



Small sorting rings
TY0001

- 15 pcs;
- ø 25,5 cm

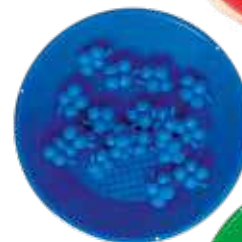

Bowls for counting beads
TY6723

- 4 bowls (yellow, green, blue, red);
- ø 18 cm

**Magnetic sorting and counting set
NS0494**

- 125 magnetic elements for counting, sorting and arranging;
- element size: 5,5 x 5,5 cm



**Wooden playing pawns. Classroom set
TY0028**

- made of wood;
- 60 pcs in 6 colours;
- size: 2,5 x 2,4 cm



**Bags with numbers
NS1982**

- 12 pcs;
- size: 8 x 12 cm



**Transparent bears
with accessories for sorting
JN0105**

Set for learning how to sort and count. It contains bears in 3 sizes, tweezers and bowls. This is a great aid for learning how to recognise the colours, how to match elements; it develops math skills and eye-hand coordination. The set is also perfect for stimulating imagination, encouraging creative thinking and improving manual skills. Rich colour palette and a significant number of elements guarantees hours of great fun. Colourful bears with accessories ensure pleasant experiences during occupational therapy or therapy for children with special educational needs. The set is delivered in a plastic box.

- 80 pcs: 72 bears in 3 sizes; 6 bowls, 2 tweezers; 6 colours;
- material: plastic; dim. of the packaging: 16 x 16 x 12 cm; age: 3+

**Geometric figures & shapes
Sorting box
EO1310**

- Wooden box with activity lid.
- 8 guide boards, 48 pattern cards;



COUNTING & WORKSHEETS



Worksheets 1 for VO3583
VO3583W

- 24 pcs; size: 11,5 x 11,5 cm

Worksheets 2 for VO3583
VO3584W

- 24 pcs; size: 11,5 x 11,5 cm

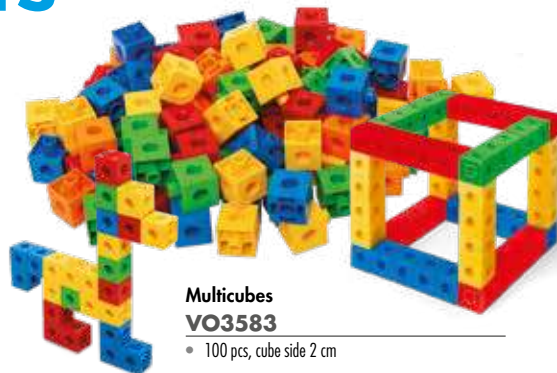

Multicubes
VO3583

- 100 pcs, cube side 2 cm



Worksheets for TY0002
TY0002W

- 24 pcs; size: 11,5 x 11,5 cm

Vegetables
TY0002

- 144 pcs (6 shapes)



Worksheets for TY7119
TY7119W

- 24 pcs; size: 11,5 x 11,5 cm

Cubes
TY7119

- 100 pcs; side 2 cm; 4 colours



Worksheets for TY0014
TY0014W

- 24 pcs; size: 11,5 x 11,5 cm

Fruits
TY0014

- ca 108 pieces (6 colours, 6 shapes)





Figure buttons NS4051

- 200 pcs (5 shapes in 4 colours)



Counting buttons TY0822

- 220 buttons in 5 colours, 2 string
- ø 4 cm

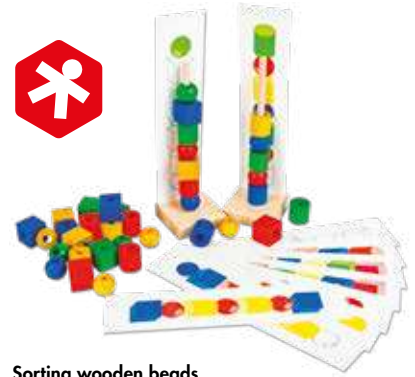

Sorting wooden beads NS0539

- 36 elements, H 3 cm;
- 2 bases, 7 x 7 cm with the rod 25 cm long;
- 10 cards, size: 27 x 5,5 cm



Lacing hands VO0538

- 72 hands (6 shapes in 6 colours), 6 strings



Lacing numbers AP2614

Numbers with holes through which a lace can be threaded. They can also be used as an aid in drawing.

- 10 plastic digits (from 0 to 9); laces in 4 colours; dim.: 18 x 18 cm;
- material: plastic; age: 3+



Geometric set EO1204

- 12 pcs; size: 22 x 17 x 6,5 cm



Numbers. Stacking game CI4556

Simple puzzle which introduces children to the world of colours and numbers. The set contains a base with pins and colourful hoops. The task is to place a tile on the base with a number and to pick the right amount of wooden hoops. To make it easier, all matching elements are painted with the same colour. There is a hole in the tile which facilitates removing it from the base. This activity develops manual skills and improves concentration.

- 66 pcs.; dim. of the base: 45 x 11 x 8 cm; material: wood; age: 3+



TRANSPARENT ABACUS



- with shapes

JN0360

A multifunctional abacus (counting frame). It includes 3 sets of transparent blocks: figures (10 shapes in 5 colours), beads (6 shapes in 6 colours) and

numbers (from 0 to 9). It's designed for counting, sorting as well as learning about colours and numbers. The abacus helps to develop coordination and motor skills.

- dim. of the base: 30 x 5 x 8 cm with a mandrel;
- material: plastic;
- age: 3+



- for sorting numbers JN0030

Manipulative puzzle which not only develops motor skills of children, but it also improves their creativity and stimulates their interest in the world of colours and numbers. The set consists of 5 pins on which colourful hoops can be put. Transparent numbers, which additionally

help to visualise mathematical operations, were prepared with older children in mind.

- dim. of the whole set: 30 x 8 x 18 cm;
- contents: 50 hoops with dim. of 5 cm, 1 cm thick in: blue, yellow, red, green, orange;
- 5 transparent pins;
- 1 transparent base, dim.: 30 x 8 x 5 cm;
- 10 numbers (0-9) in: blue, yellow, red, green;
- material: plastic, packaging: plastic bag; age 3+



- for sorting shapes JN0031

The set of figures with an abacus will introduce the children to the world of sorting and recognising colours as well as objects' characteristics. This set consists of the elements which differ not only in colour, but also in shape. Play time will

train hand-eye coordination, fine motor skills and it will improve logical thinking.

- dim. of the whole set: 30 x 8 x 18 cm;
- contents: 50 figures (disc: dim. 5 cm, thickness: 1 cm) in 5 colours: red, yellow, green, orange, blue;
- 5 pins in green, 1 base in yellow;
- material: plastic;
- packaging: plastic bag;
- age: 3+

DICES



Dice case

E10051

- set includes: 162 dice in 14 types, a snap-shut case with a compartment pad
- size: 34,5 x 7 x 27 cm

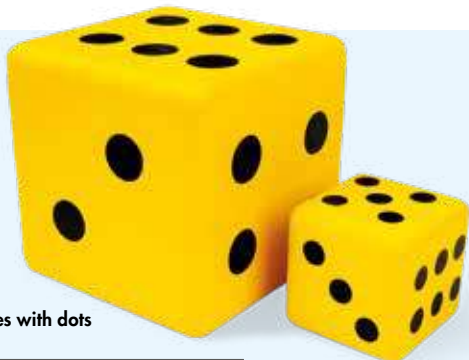

Set of foam cubes with dots

US0123

Light and big dices for counting games and mathematical operations at home or outdoors. They are made of soft and safe in use foam.

- 2 pcs; 7,5 x 7,5 x 7,5 cm; 15 x 15 x 15 cm;
- colour: yellow with black dots;
- material: foam; age: 3+



Jumbo dice - 10 pcs

IV5315

- 10 pcs;
- side 2 cm



12 Sided Foam Dice

US0432

- ø 12,5 cm



Wooden dice. Classroom set

TY0027

- 60 pcs;
- size: 1,6 x 1,6 x 1,6 cm



Cube with dots
NS1936

- size: 30 x 30 x 30 cm;
- PVC covered foam cube



Cube with numbers
NS1935

- size: 30 x 30 x 30 cm;
- PVC covered foam cube



Worksheets I for dice with pockets
NS1886W

4 sets of 6 cards featuring emotions, colours, fractions, dice dots and fitting the pockets of the cube.

- 24 pcs; 11,5 x 11,5 cm



Worksheets II for dice with pockets
NS4201

4 sets of 6 cards featuring exercise, shapes & colors, fruits, dots.

- 24 pcs; 11,5 x 11,5 cm



Worksheets III for dice with pockets
NS4205

4 sets of 6 cards featuring toys, puppets family, Christmas, emotion.

- 24 pcs; 11,5 x 11,5 cm

TIME & DATE

Clock and calendar flip chart NS0298

A clock and calendar with moveable plates for hours and dates. Helpful in explaining the notion of time.

- size: 47 x 15 cm



Demonstration Moon-Sun Clock

TY5073

- ø 30 cm



Moon-Sun Clock

TY5072

- ø 10 cm



Student clock

TY5070

- ø 11 cm



Hourglass set

EI0188

20 hourglasses in a transparent case.

- 5 colours: red (10 min), green (5 min), yellow (3 min), blue (1 min), black (30 sec)

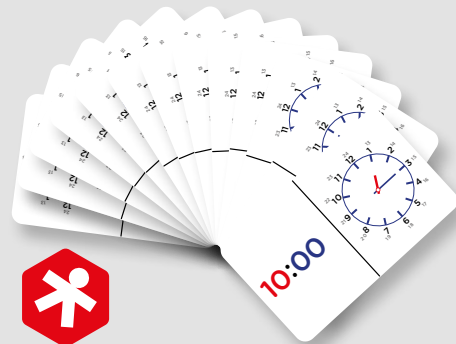
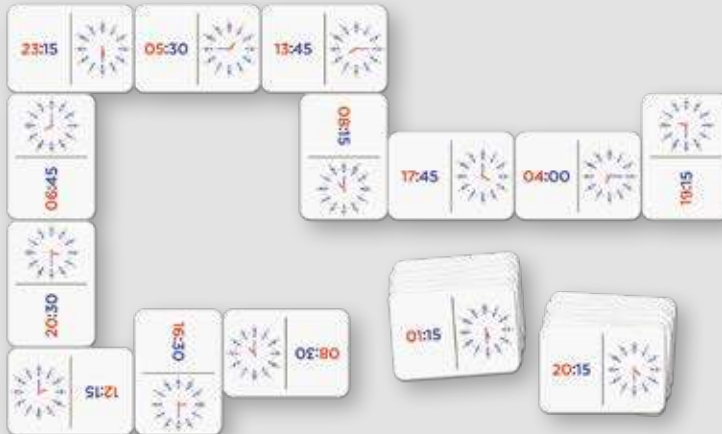

Clock dominoes NS0392

- 36 tiles (size: 6 x 8,6 cm)



Calendar NS2006

Set consists of:

- magnetic board (70 x 50 cm)
- magnets
- weather pictures x 19
- activities x 18
- days of the month x 31
- numbers to indicate the current year x 10
- cycles of the moon x 8
- arrows for pointing x 2
- frames
- text in 6 language



Magnetic clock NS2007

A great help in developing clock reading skills. The set consists of a magnetic table with a dial divided into minutes, quarters and hours.

- 2 hands
- 40 elements for time recording
- size: 50 x 50 cm



SCALES



Electronic pocket balance
HG0088

- 500 g/0,01g;
- size: 12 x 6,5 x 2 cm

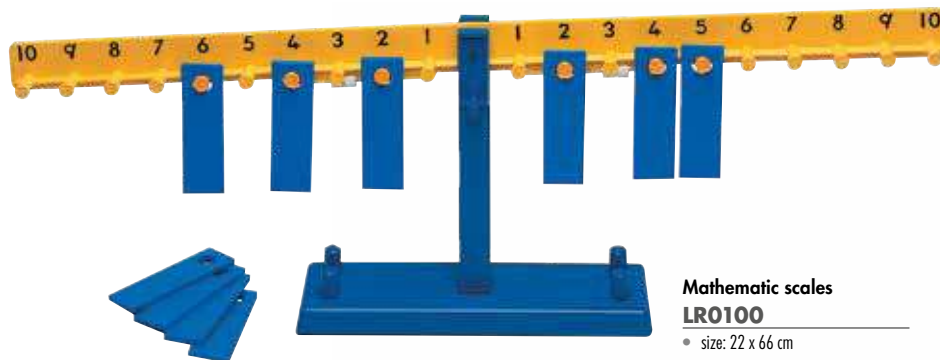

Mathematic scales
LR0100

- size: 22 x 66 cm



Elementary Pan Balance
TY2045

- size: 34 x 15 x 17 cm; 2 removable pans with 1 l scale



Scales
TY2040

- L 33 cm, H 11 cm





Junior scales with bears

TY6016

- L 37 cm, H 14 cm;
- 12 blue bears, 12 red bears



Set of balance scales

TY7206

- scale, 2 boxes, 2 pans, 48 tokens (animals), 100 rings, 20 sticks;
- age: 3+



Hooked weights set

HG0006

- A set of 9 black hooked weights.
- 10 g, 20 g x 2, 50 g, 100 g, 200 g x 2, 500 g, 1000 g;
 - on a stand



Slotted weights set

QH0037

- A set of weights with a hook.
- \varnothing 5 cm, H 17 cm

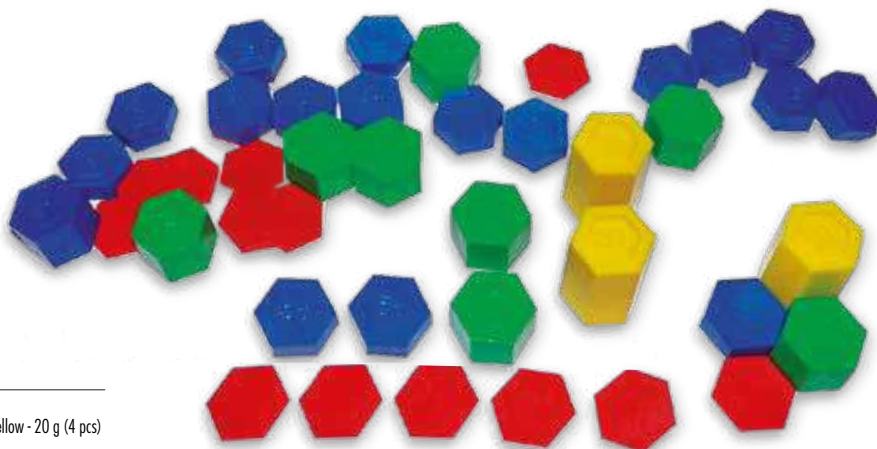

Hexagonal weights

TY8350

- 54 pieces in 4 colours for different weights:
red - 1 g (20 pcs), blue - 5 g (20 pcs), green - 10 g (10 pcs), yellow - 20 g (4 pcs)

MOSAICS

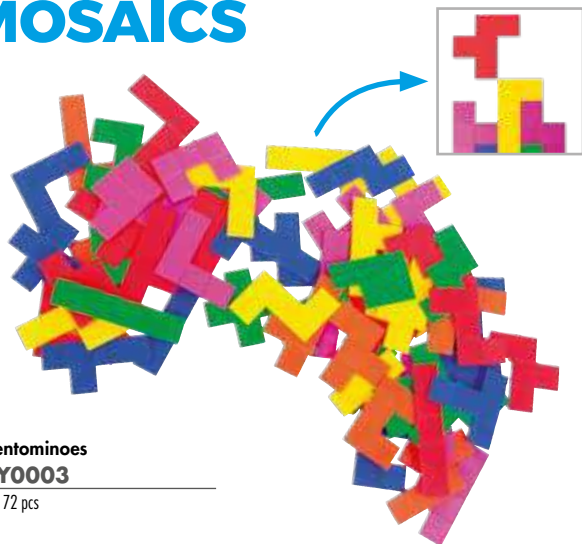

Pentominoes
TY0003

- 72 pcs

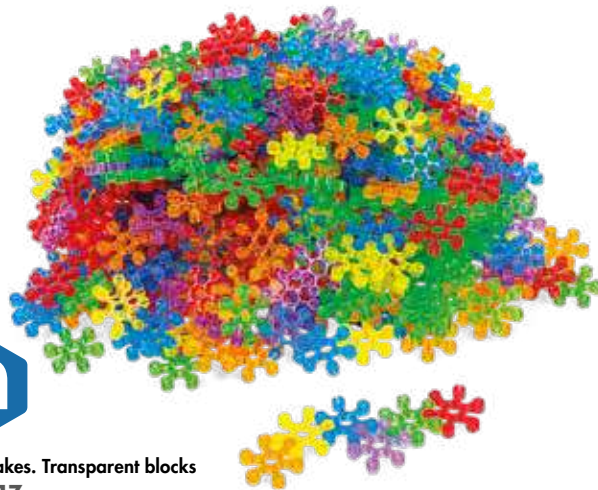

Snowflakes. Transparent blocks
JN0017

- 480 pcs, dim.: 3,8 x 0,6 cm
- material: transparent plastic; age: 3+



Plastic pattern blocks 1 cm
TY7114

- 6 colours, 248 pcs



Plastic pattern blocks 0,5 cm
TY7142

- 6 colours, 245 pcs



Worksheets for TY7114 and TY7142
TY7142W

- 24 pcs; size: 11,5 x 11,5 cm



Worksheets for TY0003
TY0003W

- 24 pcs; size: 11,5 x 11,5 cm

GEOMETRIC FIGURES & SHAPES



Transparent comparative figures JN0029

The set of transparent figures differing in size and thickness. Perfect for introducing the concept of size, shape and colour. It is also indispensable during geometry exercises. Thanks to their transparent colour they work well with the light panel. The set is kept in a box which makes moving and storing easier.

- 48 pcs.: dim. of the ring: 6 cm, 1 cm thick;
- figures: square, rectangle, triangle, circle;
- colours: yellow, blue, red;
- material: plastic;
- packaging: cardboard box, dim.: 21,5 x 6 x 13,5 cm;
- age: 3+



Wooden geometric blocks VG6164

- 48 elements: triangle, square, rectangle and circle in 6 colours
- wooden box size: 25 x 15,5 x 8 cm
- age: 3+

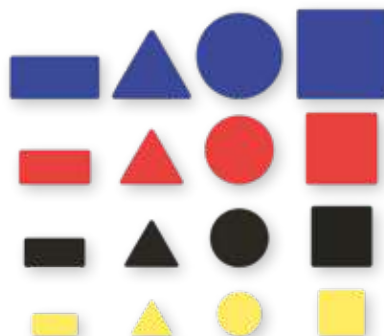

Magnetic geometrical figures NS3015

- 80 pcs;
- colours: blue, red, black, yellow; colour chosen at random



Geometric figures TY0007

- 60 pcs in 5 shapes, 3 colours, 2 sizes and 2 thicknesses
- max. side 1,7,5 cm, thickness 0,6 cm; box size: 23 x 17 cm

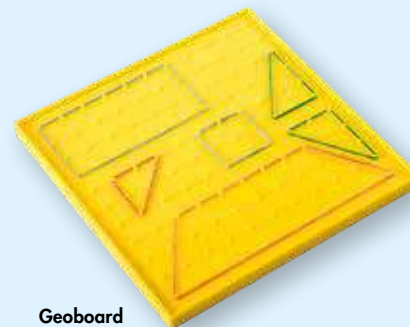

Geoboard TY6526

- size: 21 x 21 cm



Fraction and geometry set TY6525

- size: 21 x 21 cm

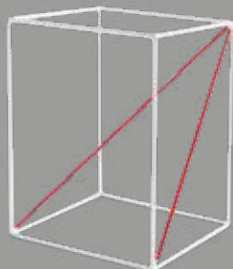

Cube with diagonals
HG0030

- size: 13 x 20 cm;
- material: metal

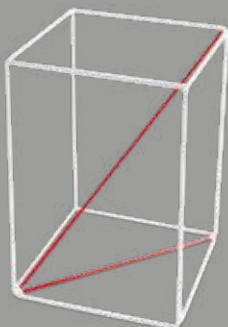

Cuboid with diagonals
HG0031

- size: 20 x 15 cm x 13 cm;
- material: metal

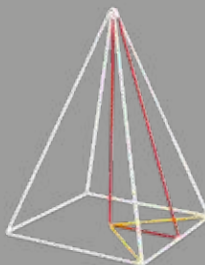

Square pyramid
HG0032

- size: 16 x 25 cm;
- material: metal

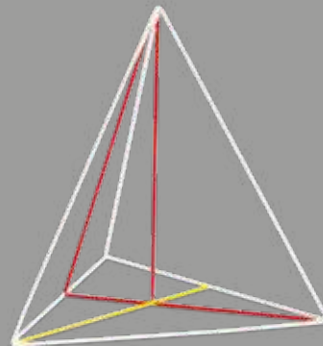

Triangular pyramid
HG0033

- size: 23 x 25 cm;
- material: metal

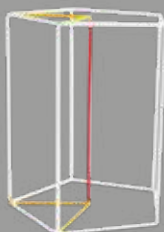

Pentagonal prism
HG0034

- size: 10 x 20 cm;
- material: metal

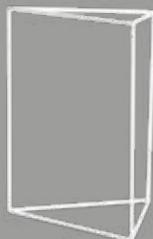

Triangular prism
HG0035

- size: 10 x 20 cm;
- material: metal

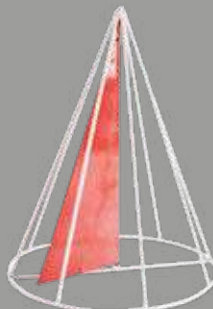

The formation of cone
HG0036

- size: 19 x 23 cm;
- material: galvanized wire



The formation of roller
HG0037

- size: 15 x 18 cm;
- material: galvanized wire

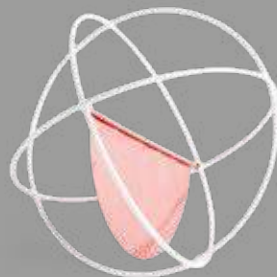

The formation of ball
HG0038

- size: 19 x 19 cm;
- material: galvanized wire



Geometrical solid wooden blocks. Classroom set

TY0029

A practical set of 3D geometric shapes very of wood, the blocks are durable and will be usable for a long time.

- the set consists of 29 elements;
- H ca. 5 cm

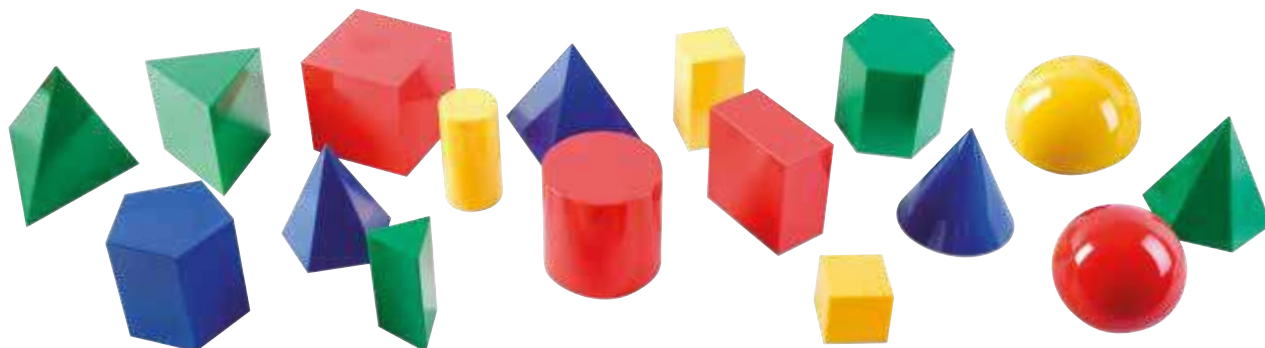

Large geometric shapes

TY0406

- 17 pcs, 4 colours

Large geometric transparent shapes

TY0405

- 17 pcs, 3D shapes

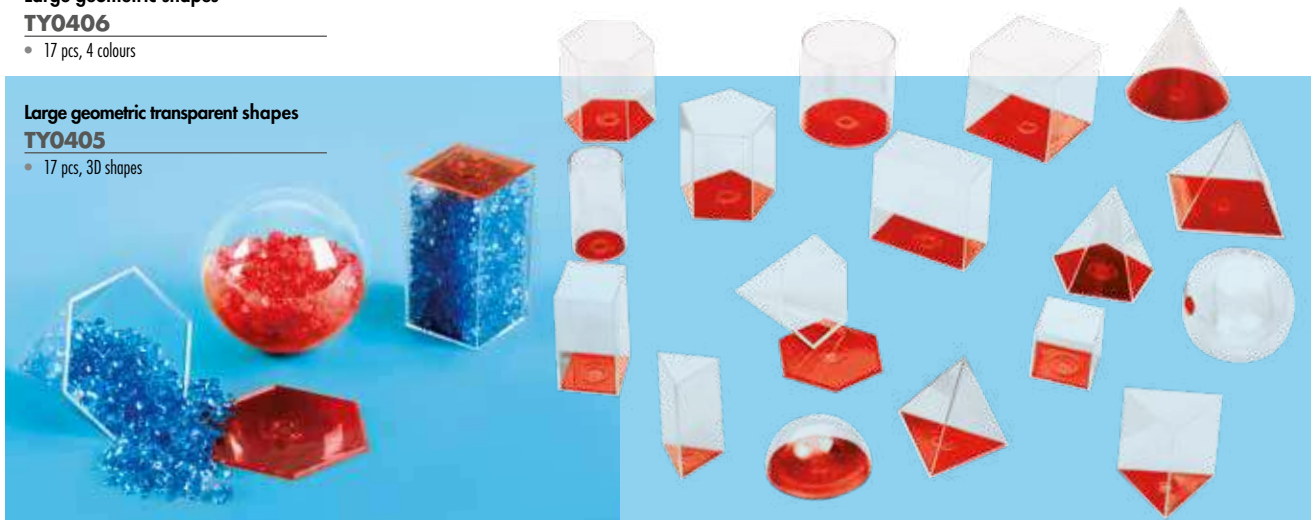

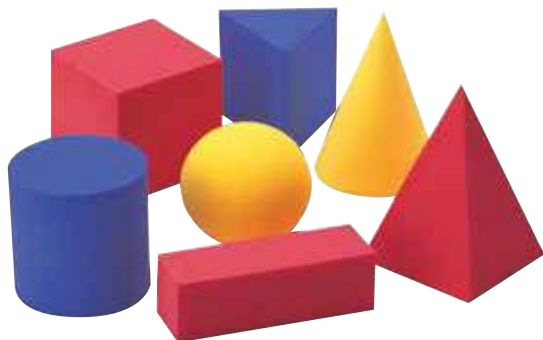

Educational foam geometric solids MW0922

- 12 pcs

wooden box
with an acrylic lid

made of
rubber wood



Tangram VG5630

The whole product is made of high quality rubber wood stored in a wooden box

with an acrylic lid. A pile of cards with patterns is provided for children to match. It also encourages children to create more patterns using their imagination.

- size: 26,5 x 2 x 20 cm



Learning Maths VG5002

Learn maths with this educational toy in a fun way. Made of solid wood beads and metal device in a sturdy structure.

- size: 29 x 7,5 x 14,5 cm

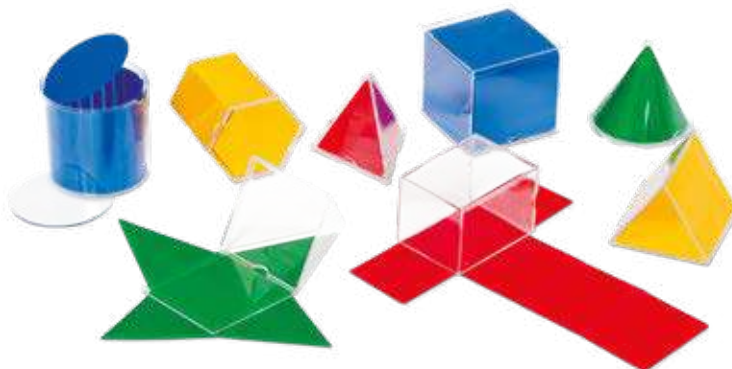

Foldable shapes LR0921

- 10 transparent plastic solids + their grids;
- ca 10 cm

Unfolded plot of 10 shapes TY8410

- 10 plastic shapes

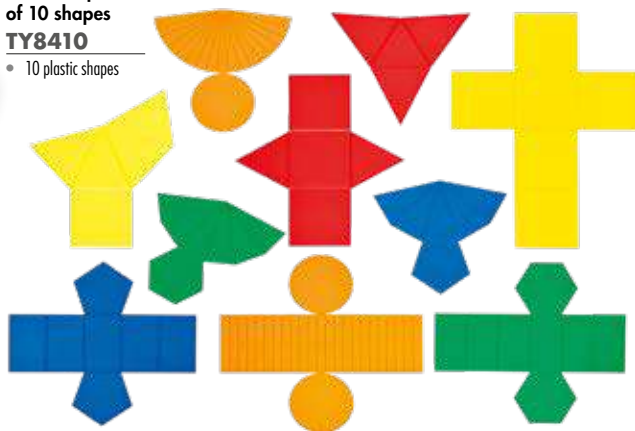

Shaped abacus HG0011

- size: 22 x 13,5 x 21 cm;
- age: 3+



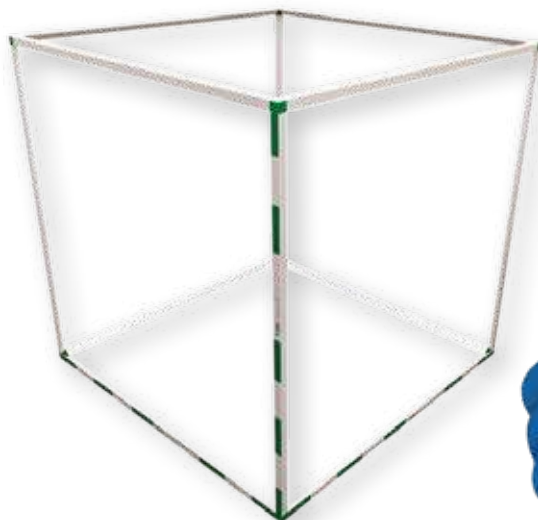

1 cubic meter TY8411

- foldable set to demonstrate the volume of 1 m^3 ;
- 12 rods, 8 connectors;
- age: 4+



Measuring feet NS3016

- made of colourful easy-to clean plastic;
- 20 feet; L 10 cm, 15 cm, 20 cm, 25 cm



Geo strips IV4159

Consists of 68 strips of various sizes, a box of connectors, a protractor, and a set of 11 carefully graded work cards.

- length 33; 28,5; 22; 19; 17,5; 15,2; 12,8; 9,5 cm
- age: 6+



Tooling Meter Stick TY7201

- 5 pcs; L 1 m

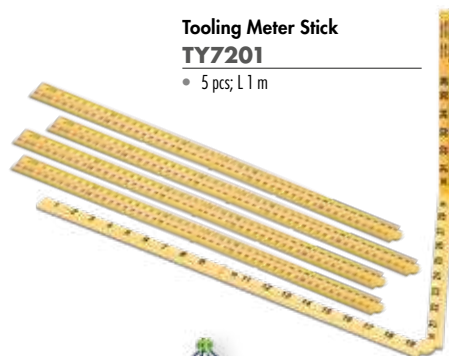

Construction set VO2182

- 80 balls (6 colors); \varnothing 1,7 cm;
- 250 rods (6 lengths, 6 colors); 5 – 14 cm



Worksheets for construction set. Figures VO8151W

- 24 pcs; size: 11,5 x 11,5 cm

Worksheets for construction set Solids Geometry VO8152W

- 24 pcs; size: 11,5 x 11,5 cm

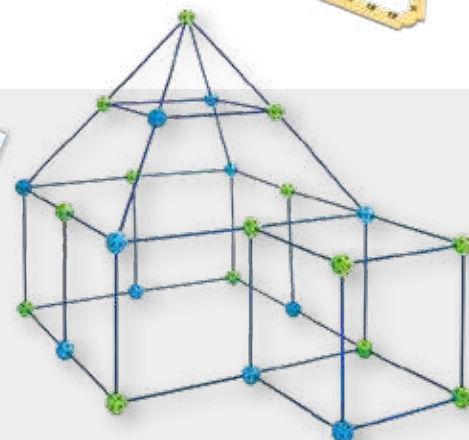

Construction Forts BO1203

- pole: 45 pcs; pole size: 37 cm;
- ball: blue x 14 pcs, green x 13pcs; ball \varnothing 5,2 cm

DECIMAL SYSTEM



Maths blocks VG6166

- 308 elements in 9 colours;
- wooden box 32,5 x 17,5 x 4 cm;
- age: 3+

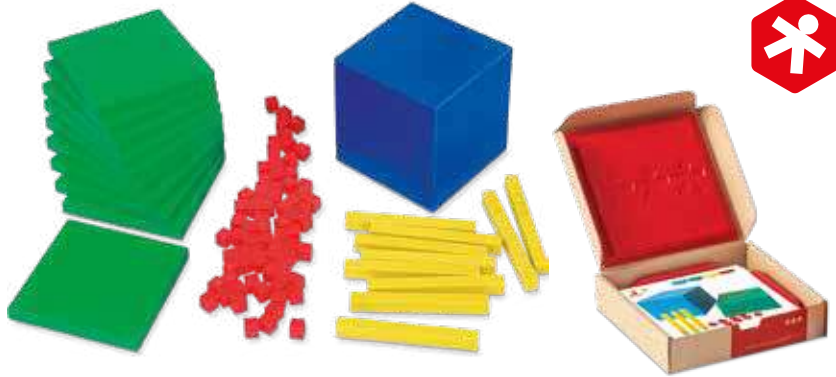

Maths blocks VO1940

- 4 colours: red, yellow, blue, green;
- age: 3+

- 100 cubes (1 x 1 cm),
- 10 bars (1 x 10 x 1 cm),
- 10 plates (10 x 10 cm),
- 1 big block (10 x 10 cm)

Worksheets for VO1940 VO1940W

- 24 pcs; size: 11,5 x 11,5 cm



Train. Educational blocks JN0089

By loading up the carts with blocks and connecting them together, the toy helps to understand the concept of units, tens, and hundreds. It helps to visualize basic

math equations like addition, subtraction, multiplication, and division as well as the concepts of greater than / less than.

- 10 transparent carts – block containers; 100 dices (height: 2 cm) in 5 colours;
- material: plastic; age: 3+

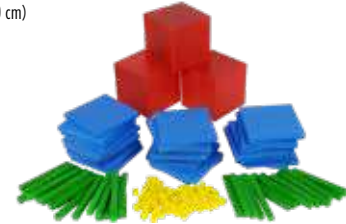

Decimal system. Classroom kit JN0051

- set of 183 elements including 3 red cubes, 30 blue squares, 50 green sticks and 100 yellow units;
- age: 3+

Tokens with boards. Decimal system JN0079

Classroom set for learning about numbers and their properties. It also helps to introduce the students to the world of arithmetic. By manipulating the tokens, it is possible to explain the principles of operations in the decimal system to the students and to improve their efficiency in performing basic arithmetic operations.

- each board consists of 10 compartments in which the two-coloured tokens can be placed. 220 pcs: 20 white boards with dim.: 16,5 x 6,5 cm, 200 bilateral tokens (red on one side, blue on the other) with dia. 2,5 cm;
- material: plastic; age: 3+

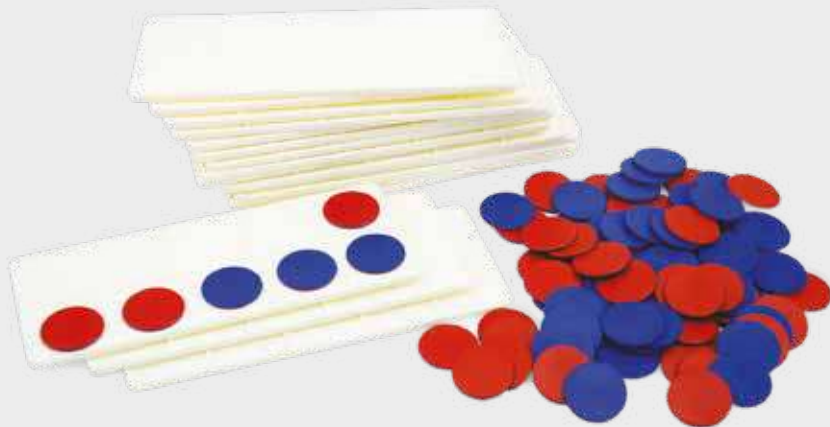

FRACTIONS



Equivalency cubes set JN0041

The set of colourful bricks with a print depicting fractions. Each fraction is represented by one colour and by the amount of cubes forming one whole. This set helps the students to understand the concept of expanding and reducing fractions, and how to perform basic arithmetic operations on them. All elements of the set are delivered in a plastic bag.

- 51 pcs with a print depicting fractions in 9 colours: red (1), pink (1/2), orange (1/3), yellow (1/4), green (1/5), blue (1/6), navy blue (1/8), purple (1/10), black (1/12);
- material: plastic;
- dim.: 2 x 2 x 2 cm;
- age: 3+



Worksheets for Equivalency cubes set JN0041W

Set of 24 worksheets for the Equivalency cubes set (JN0041W).

- dim. of a single piece: 11,5 x 11,5 cm;
- the combination ideas vary in their level of difficulty;
- all worksheets can be easily stored thanks to the box included in the set;
- age: 3+

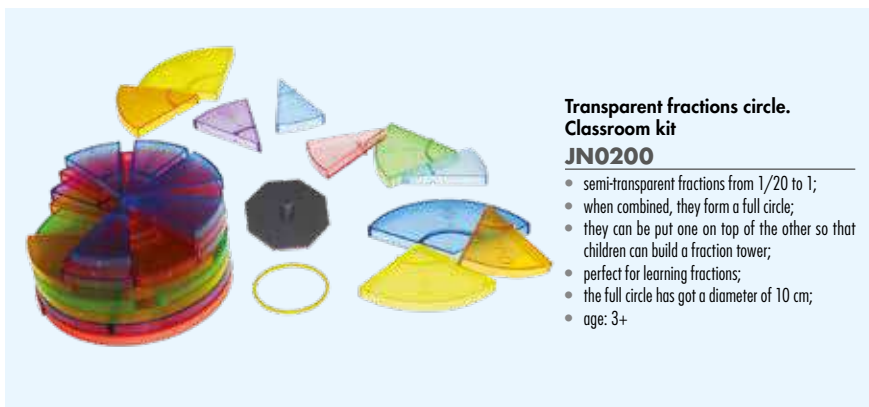

Transparent fractions circle. Classroom kit JN0200

- semi-transparent fractions from 1/20 to 1;
- when combined, they form a full circle;
- they can be put one on top of the other so that children can build a fraction tower;
- perfect for learning fractions;
- the full circle has got a diameter of 10 cm;
- age: 3+

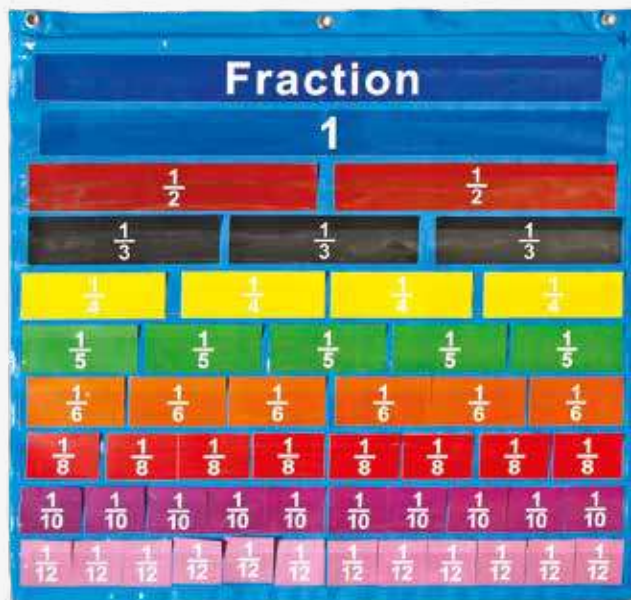

Fraction hanging pocket organizer
TY0034

- 51 pcs
- wall hanging size: 67 x 67 cm; age: 7+

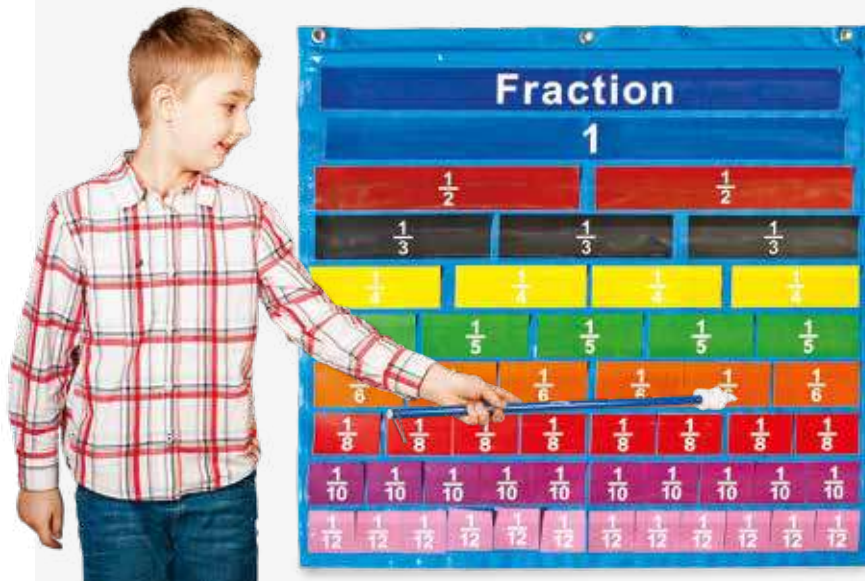

Fraction colour board
TY0032

- 51 pcs
- base plate size: 23,5 x 27,5 cm;
- age: 7+



Decimal fraction board
TY0033

- 51 pcs
- base plate size: 23,5 x 27,5 cm;
- age: 7+

Fractions and percentages.**Magnetic set****NS1366**

The set consists of dividable circles and rectangles with a part painted over to help children recognize a fraction as part of a whole and match a picture with the value (vulgar and decimal fractions, percentages) it presents. The set includes a large square magnetic chessboard divided into 100 boxes and magnetic squares which match them. Pupils can practise fractions and percentages for any value in the 1–100 range. Magnetic fractions help to learn the basic

properties of vulgar / decimal fractions and percentages, and relationships between them. It will also help children understand abstract concepts to do with operations on fractions and percentages. 230 pcs including:

- cardboard elements:
9 circles D 10 cm,
51 rectangles with vulgar fraction values;
- magnetic elements:
9 circles D 30 cm,
9 rectangles with a graphic (30 x 20 cm) of a given fraction,
1 chessboard 110 x 1,0 cm,
100 squares 10 x 10 cm,
51 rectangles with vulgar fraction values; age: 7+

cardboard elements



magnetic elements

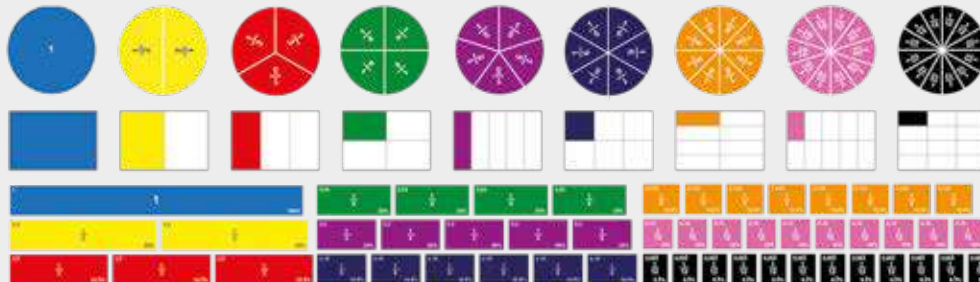

magnetic squares and chessboard

**230 pieces!****Fractions flipchart****NS1298**

A set of ring bound charts demonstrating the relationship between an amount in graphic form and a fraction, decimal number and percentage.

- 5 types of activity

Wooden dice with fractions**TY0030**

An excellent teaching aid to explain vulgar fractions and mathematical operations on them. Each side of the dice presents a different fraction value. Each value appears several times, thus enabling operations.

- 28 pcs in 4 colours;
- size: 2,5 x 2,5 x 2,5 cm;
- material: wood;
- age: 3+



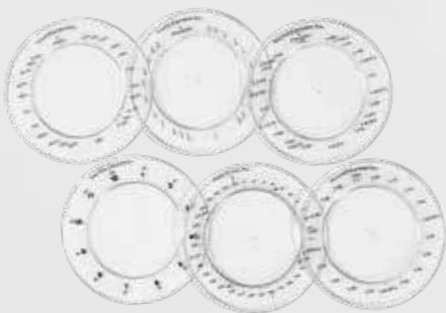

Fraction disks

TY3001

A set of 6 transparent disks with fractions to perform, compare and size imaging. It makes it easier to understand fractions and different ways of writing parts of the whole. Putting the disks on each other can illustrate the principle of converting fractions into percentages and vice

versa. It allows you to easily present the concept of equivalence - percentages can be represented by ordinary and decimal fractions.

- 6 items, ø 14 cm;
- 6 maths disks: protractor 360°/ compass, common fractions in range [0,1], decimal fractions in range [0,1] (including recurring decimals), decimal fractions in range [0,1] (to an accuracy of 1/100), percentage, time units (seconds/minutes/hours)



Fraction disks. Basic level set

TY3002

- 6 math discs, ø 14 cm
- 24 worksheets; size: 11,5 x 11,5 cm
- 6 bases for worksheets and math discs



Worksheets for TY3001 Basic level TY3001W

- 24 worksheets, size: 11,5 x 11,5 cm in a box



Fraction disks. Advanced level set

TY3012

- 6 math discs, ø 14 cm
- 24 worksheets; size: 11,5 x 11,5 cm
- 6 bases for worksheets and math discs



Worksheets for TY3001 Advanced level TY3011W

- 24 worksheets; size: 11,5 x 11,5 cm in a box



SETS AND GAMES

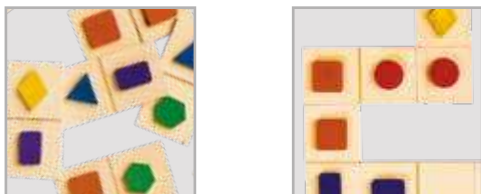

Geometrical domino
EN3103

- 28 pcs; box size: 37,5 x 3,6 x 23 cm



Number dominoes 0-6
NS0391

- 54 tiles (6 x 8,6 cm)



Monograph of a number
NS1370

According to the core curriculum, formation of the concept of natural number is the paramount goal of mathematical education at early school age. „Monograph of a Number“ meets this goal. The set contains 21 boards with numbers from 0 to 20 and is an exhaustive introduction to numbers in the required cardinal, ordinal and measuring aspects. Besides, each board shows the handwri ten and

printed versions of a number with clear indication how to write the number correctly. An original task with the use of the board is to get pupils involved in physical activity. Each board has a picture to encourage children e.g. to squat down the right number of times. With the help of Monograph, a child will acquire elementary knowledge through play and by using ordinary objects form immediate surroundings.

- 21 double-sided boards with numbers 0 to 20;
- size: A4



Shake and count. Mathematical operations JN0820

Educational aid which supports the process of learning basic mathematical issues. Cubes with numbers and symbols of addition and subtraction were placed inside transparent hemispheres. The children have to shake them and see what kind of operation they have to perform. This game will surely provide a lot of fun and excitement. 6 elements:

- dim. 10 cm, colours: red, green, yellow, orange, blue, purple;
- material: plastic; packaging: plastic bag; age: 3+



Euro set VO2832

- set of 65 notes and 110 coins



Butterflies EO0316

- ø 24 cm

LOGIC GAMES



Battleships
EI0008

A naval strategy game of hit or miss, for 2 players.

- includes: self contained case with 2 playing areas, manual;
- age: 6+



Block Tower
VG5621

A game easy to learn and play for fun. Each player needs to take out a block of the color same as the dice from the tower by turn. The one who makes the tower fall loses

- age: 3+



Who is who? A game of hidden identity
EI0009

- for 2 players
- set includes: 2 play units, set of 24 character cards, manual
- age: 6+



Board game Fruit orchard
NS0399

My Fruit Garden is a challenge puzzle game aiming of helping children identify similar objects (forms and colors) and then group them together by following the different formations proposed. Children can therefore learn to sort objects in space and develop their understanding of geometry in space.

- 1 board (34 x 34 cm), 16 fruits, 24 worksheet cards

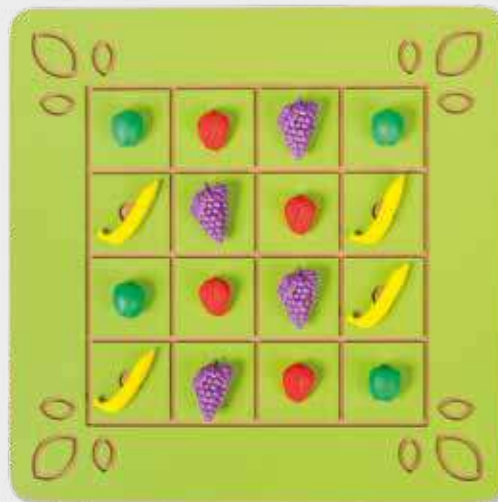

logicubes

ZEBRA



These printed wooden cubes are a complete educational set which develops logical and spatial thinking and thus it prepares children for elementary programming. The game comes in three versions, each meeting different needs and skills of the users. The complete set comprises cubes, reference charts, grid transparencies and self-evaluation charts, and their number depends on the level of difficulty. Simple rules, the simple structure of the set and the self-evaluation charts develop independent activity irrespective of age. All the cubes have the same number and pattern configurations. They are elements of one of 30 suggested jigsaws. We offer 3 sets of cubes (of 9, 16 or 25 pieces). The worksheets are numbered according to the level of difficulty. The cubes can be arranged freely on the table or on the tray provided. More demanding players will be interested in the 3D version (with worksheets and a tray).

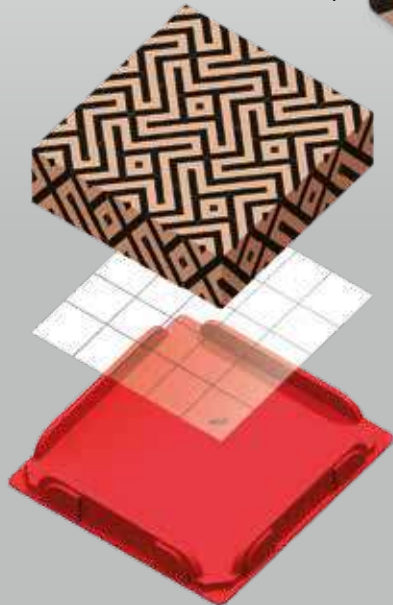

Logi-cube Zebra. Set of 25 cubes
LA0025

- 25 cubes, grid transparent pad, instruction with 30 examples, box with a holder for cubes



Logi-cube Zebra. Set of 16 cubes
LA0016

- 16 cubes, grid transparent pad, instruction with 30 examples, box with a holder for cubes



Logi-cube Zebra. Set of 9 cubes
LA0009

- 9 cubes, grid transparent pad, instruction with 30 examples, box with a holder for cubes



Pyramid. 3d holder and worksheets for Logi-cube Zebra
LA0320

- 3 trays 18,5 x 18,5 cm for building pyramids
- 12 double-sided worksheets 15 x 15 cm for 24 models;
- instruction

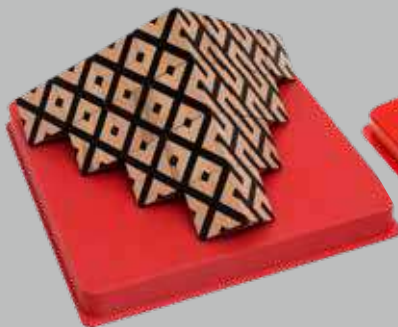

Worksheets for 9 Logi-cube Zebra cubes
LA1209

- 15 double-sided cardboard worksheets with 30 patterns, 30 transparent printed check sheets, instruction;
- 9 x 9 cm

Worksheets for 16 Logi-cube Zebra cubes
LA1216

- 15 double-sided cardboard worksheets with 30 patterns, 30 transparent printed check sheets, instruction;
- 12 x 12 cm

Worksheets for 25 Logi-cube Zebra cubes
LA1225

- 12 double-sided cardboard worksheets with 24 patterns, 24 transparent printed check sheets, instruction;
- 15 x 15 cm

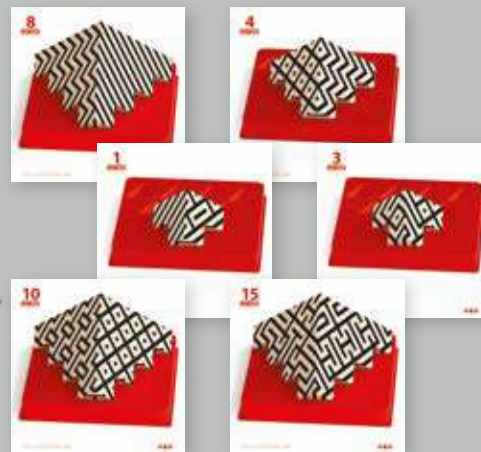
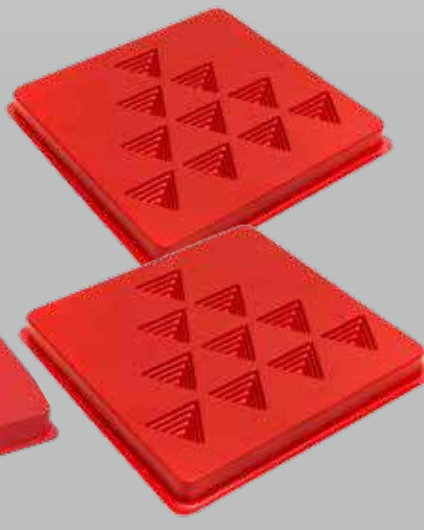

GEOGRAPHY AIDS

MAPS & MAPS HANGERS

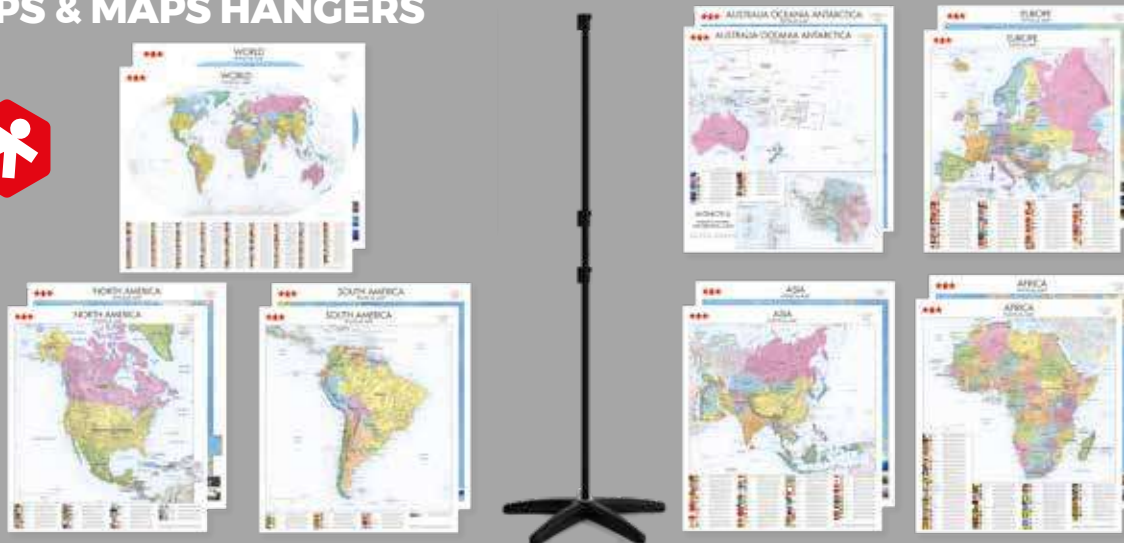

Wall maps with a hanger – English set

NS8301

Rich collection of physical and political maps of individual continents and the whole world. Contours of the landforms are marked with colours. The maps show the current territories of countries with their capitals and the most important cities. Additionally, enriched with

photographs of the most famous natural monuments with their descriptions. The political maps provide information about: flag, coat of arms, official language, capital city, political system, area, population, monetary unit converted into the zloty exchange rate, dominant religion, time zone, internet domain, codes (car, plane, telephone), GDP per person, credit assessment of the current economic situation and data on threats to

personal security in public places. All maps were made of durable banner material with a handle. This set includes a map hanger made of a metal rod mounted on a stable, plastic, star-shaped base. Its height is easily regulated (max. height: 2,0 cm) thanks to the telescopic tube with a lock. The hanger is easy to assemble and does not take up much space.

The set contains:

- NS8331 - Africa. Physical Map - dim. 150 x 1,0 cm, scale 1 : 6 500 000;
- NS8332 - South America. Physical Map - dim. 150 x 1,0 cm, scale 1 : 6 500 000
- NS8333 - North America. Physical Map - dim. 150 x 1,0 cm, scale 1 : 5 500 000;
- NS8334 - Australia, Oceania, Antarctica. Physical Map - dim. 150 x 1,0 cm, scale 1: 8 300 000, map scale of the Bransfield Strait area 1: 1 000 000;
- NS8335 - Asia. Physical Map - dim.: 150 x 1,0 cm, scale 1 : 7 500 000;
- NS8336 - Europe. Physical Map - dim. 150 x 1,0 cm, scale 1 : 3 500 000;
- NS8337 - World. Physical map - dim. 170 x 1,0 cm, the scale at the equator is approx.: 1: 20 000 000;
- NS8341 - Africa. Political Map - dim. 150 x 1,0 cm, scale 1 : 6 500 000;
- NS8342 - South America. Political Map - dim. 150 x 1,0 cm, scale 1 : 6 500 000;
- NS8343 - North America, Political Map - dim. 150 x 1,0 cm, scale 1 : 5 500 000;
- NS8344 - Australia, Oceania, Antarctica - dim. 150 x 1,0 cm, scale 1: 8 300 000, map scale of the Bransfield Strait area 1: 1 000 000;
- NS8345 - Asia. Political Map - dim. 150 x 1,0 cm, scale 1 : 7 500 000;
- NS8346 - Europe. Political Map - dim. 150 x 1,0 cm, scale 1 : 3 500 000;
- NS8347 - World. Political Map - dim. 170 x 1,0 cm, the scale at the equator is approx. 1: 20 000 000;
- ANW600 Map Hanger



MAPS NS SERIES



Series of large Nowa Szkola wall maps showing all continents separately and map of the world. High quality of printing provides great transparency. Maps show in a clear way: Current territories of countries are marked in colours as well as problematic territories, capitals and larger cities

- natural biosphere of the Earth (rain forest, deciduous forest, taiga, tundra, mountain areas, ice-sheets, savannas, deserts, coral atolls), agricultural and pastoral areas
- physical map include various photographs showing characteristic landscapes and natural wonders.

- political maps are provided with a description of the state: flag, emblem, official language, capital, political system, area population, monetary unit converted into PLN, dominant religion, time zone, internet domain, codes (car, airplane, phone), GDP per person and credit rating of its current economic situation, and data on personal security threats in public places.

If you are interested in having one of our maps, please contact us. We will prepare an individual version of the map in the chosen language.

Or on special request we will provide a map in the language of your choice.



**World. Physical Map
NS8337**

- size: 170 x 15,0 cm, scale on the equator is about 1 : 20 000 000



**World. Political Map
NS8347**

- size: 170 x 1,0 cm, scale on the equator is about 1 : 20 000 000

PHYSICAL MAPS

These relief physical maps cover particular continents or the whole world. Colours mark the relief of terrain. The relief of the hydrosphere is marked with contour lines. The maps show particular countries with their current borders, capitals and major cities. At the bottom of each map there are photographs of the most famous nature monuments accompanied by short descriptions.



Africa
NS8331

• size: 150 x 1,0 cm, scale ca. 1 : 6 500 000



South America
NS8332

• size: 150 x 1,0 cm, scale ca. 1 : 6 500 000



North America
NS8333

• size: 150 x 1,0 cm, scale ca. 1 : 5 500 000



Australia, Oceania, Antarctica
NS8334

• size: 150 x 1,0 cm, scale ca. 1 : 8 300 000



Asia
NS8335

• size: 150 x 1,0 cm, scale ca. 1 : 7 500 000



Europe
NS8336

• size: 150 x 1,0 cm, scale ca. 1 : 3 500 000

POLITICAL MAPS

These relief political maps cover particular continents and the whole world. Colours mark the current territories as well as territorial claims. The maps show capitals and major cities and are accompanied by information about each state (its flag, national emblem, official language, capital city, political system, area, population, unit of currency and its conversion into PLN, predominant religion, time zone, internet domain, vehicle registration code, aircraft registration code, telephone code, GDP per capita, current credit rating, information about threat to personal security in public places). The maps - ideal not only for school - are made of durable banner material and each has a hanger.



Africa
NS8341

- size: 150 x 1,0 cm, scale ca. 1 : 6 500 000



South America
NS8342

- size: 150 x 1,0 cm, scale ca. 1 : 6 500 000



North America
NS8343

- size: 150 x 1,0 cm, scale ca. 1 : 5 500 000



Australia, Oceania, Antarctica
NS8344

- size: 150 x 1,0 cm, scale ca. 1 : 8 300 000



Asia
NS8345

- size: 150 x 1,0 cm, scale ca. 1 : 7 500 000.



Europe
NS8346

- size: 150 x 1,0 cm, scale ca. 1 : 3 500 000



**Magnetic world map with components. Two-sided
VG4508**

Double-sided board showing the map of the world with a dry-erase surface for writing and drawing. It is equipped with magnetic elements which have to be put in the right places on the map to reveal secrets from around the world. Play time with this toy will allow the children to broaden their knowledge and to become fascinated by geography, history or fauna and flora. Additionally, it develops hand-eye coordination, dexterity, as well as imagination and the ability to make precise movements

- 106 magnetic elements, double-sided board;
- material: wood, magnet; meas. of the packaging: 72,5 x 46 x 0,9 cm; age: 3+

COMPASSES AND BINOCULARS



**Geological compass
CO4074**

Compass has a full metal body and all the necessary functions: clinometer, bubble level, tripod attachment and 360-degree eyepiece.

- size: 65 x 95 mm;
- liquid filled;
- clinometer, bubble level, 2 scales, tripod fixing



**Military type compass
HG0007**

- light but durable aluminium casing;
- size: 7,5 x 6 x 3 cm



**Compass with mirror
HG0100**

It can be worn on the neck thanks to the attached string. Its bezel has 360 degree markings, sighting slot and wire for determining the azimuth, and a mirror which aids in sighting bearings.

- size: 6,4 x 11,8 cm;
- material: plastic; has a mirror, mini ruler, magnifying glass and silicon legs



Binoculars 10 x 25 TS3000

High quality binoculars with 10 x magnification and great optical properties.

- magnification: 10 – 25x;
- lens diameter: 2,5 cm;
- field of view: 5,5°;
- prism: roof, bk7;
- belt and bag included in the set



Binoculars 8 x 21 with a zoom LV0001

A compact and handy case makes the binoculars an ideal companion in almost every activity on fresh air. Fully coated optics and their solid mechanics faithfully replicate colourful images. Prism and lenses are made of BaAK-7 material. Lens surfaces are fully blue coated. Binocular characteristics: central focusing, individual dioptre adjustment, durable, rubber case.

- magnification x 8, lens diameter: 21 mm, binocular eyepiece diameter: 14 mm, field of view: 128m/1000m, exit pupil diameter 2,75 mm, exit pupil distance: 12 mm, angle of the view: 7°, focal length: 10ft/3m dim.: 9 x 11,8 x 5,6 cm, weight 0,21 kg



Binoculars 10x50 MX0050

- model 10 x 50 WA;
- magnification 10x;
- lens diameter 50 mm;
- K9 prisms;
- field of view 122 m at 1000 m;
- resolution: 5,97°;
- weight 750 g;
- the set includes a bag and strap

MAGNIFIERS



Illuminated magnifying glass 65 mm HG0065

- light source: 5 LED bulbs (4 white + 1 UV);
- magnification: 2,5 x (large lens); 25 x and 55 x (small lenses);
- power supply: 4 button-cell batteries (included);
- material: ABS + glass;
- lens: diameter 65 mm; 22 mm thick;
- handle length: ca 120 mm



Illuminated magnifying glass 90 mm HG0090

- main lens 90 mm (2,5x);
- macro lens inset 21 mm (4,5x);
- lens 20 mm (25 x), lens 10 mm (55x);
- dim: 225 x 100 x 30 mm;
- 4 wide-angle directional LED bulbs switched over through repeated pressing the button in the handle;
- the central bulb emits UV light which helps see what sometimes cannot be seen in normal light;
- power supply: 4 button-cell batteries AG10 (included);
- ergonomic non-slip plastic handle



Illuminated magnifying glass TS17926

Optical instrument for direct observation of small objects. Round magnifying glass, perfect for reading books, maps, and newspapers. It is great not only for philatelists and electronics specialists as it may come in handy at home. It's made of two lenses.

- 2 x led;
- round field of vision (magnification x 2,5), with improved convex lens x6;
- lens: 90 mm, 6 dioptries (magnification x 2,5)
- lens: 21 mm, 12 dioptries (magnification x 4);
- led type: 2 ultra-bright leds (noninterchangeable);
- led colour: white;
- power supply: 2 x 1,5 v AA (not included in the set);
- length: 23 cm;
- weight: 75 g; age: 8+



Lens
TY1150
• 12 pcs



Industrial folding magnifier
QH2711

- Double, folding acrylic magnifier.
- magnification 10x;
 - lens diameter 3 cm

LENS



Large magnifier for observation
LR2774

Big magnifier with a magnification factor of 4.5 x. Perfect for observing plants, animals or insects. The built-in stand allows the user to conveniently observe the specimens.

- length: 20,5 cm, dia.: 11,5 cm, 2,5 cm thick, colour chosen randomly, material: plastic, glass; age: 3+





**Big magnifying glass
with kaleidoscope glasses**

JN0260

Set of durable magnifying glasses to discover the world in a new perspective. High quality lenses with a kaleidoscopic effect ensure great visual sensations. They are equipped with big handles suitable for little hands or people with disabilities.

- 6 pcs; frame in 6 colours; age: 18 months +



Big magnifying glasses

JN0028

Big magnifying glasses for examining and observing animals, plants and objects under magnification. High quality lenses also help children to learn about colours.

- 6 pcs; frame in 6 colours; in a cardboard box; age: 18 months +



ASTRONOMY

Transparent astronomy firmament model

AM0300

A 3D star atlas. It explains in an accessible way the earth's relationship to stars and other celestial bodies.

- set contents: celestial globe (ø 32 cm) with an earth globe (ø 8,5 cm);
- inside teacher's guide



Telescope

E10780

- optical system: refractor (lens telescope);
- magnification: 300 x;
- diameter: 45 mm;
- focal length: 600 mm;
 - focal ratio: f/13;
- resolving power: 2,57";
- magnitude: 10,8 mag;
 - focuser: 0,98

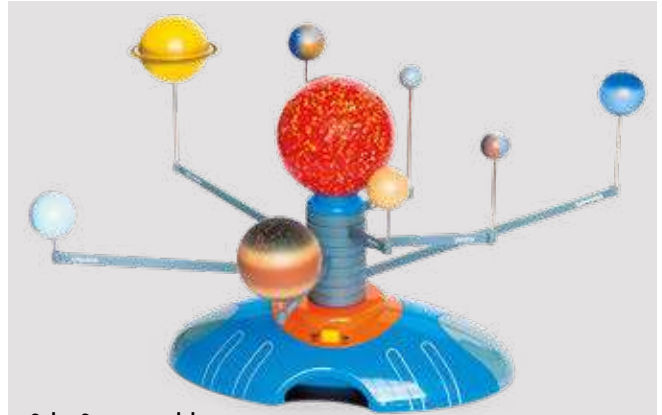

Solar System model

VO8500

A motorized model (batteries not included).

- size: 34,5 x 26 cm x 17 cm;
- automatic rotation;
- voice interactive



LANDFORM

Topography. The suitcase with teaching aids, worksheets and lesson scenarios

NS6113

Set of models and photographs which can be used to introduce basic concepts related to topography and geomorphology of the Earth's surface. Contents of the suitcase allow students to observe mountains, plateaus, plains, hills, rivers and oceans. This set presents all important characteristics of a given landform. It is also equipped with substantive materials for the teacher and students. 9 models: mountain, plateau, mountain river basin, rock formations (Danxia Mountains), coast, aeolian terrain, karst landscape, hilly basin, plain; 3 lesson scenarios; 63 worksheets,

- dim.: 11,5 x 8 cm; dim. of the suitcase: 55 x 15,5 x 46 cm; age: 5+

3 lesson scenarios

63 worksheets



3D mountain model. Topography

NS6141

This plastic model of a volcanic mountain was specially designed to demonstrate the creation of the contour lines and to help to explain their functions. The equipment of the set allows the students to convert a

three-dimensional model into a two-dimensional contour drawing. The transparent model can be placed on the projector and presented to the class.

- meas. of the model: 34 x 20 x 8,5 cm;
- overlay, 32 x 18 cm; black crayon, food colouring;
- material: plastic; age: 8+



Volcano kit

EI0011

- 15 elements; instruction manual;
- age: 10+



Model of a karst cave with landform in cross-section

HG0453

High quality model presenting a karst cave and landforms in cross-section. The model consists of 2 elements. It is possible to observe the interior of the cave with different karst forms, after removing the top. Inside the cave stalactites, stalagmites and stalagnates are precisely marked.

- dim.: 30 x 45 x 30 cm; 30 x 45 x 30 cm



Soil set

RV0303

It consists of: claysoil, loamy soil, chernozem, purple soil, paddy soil, braunerde, sandy soil and humus soil.

- 8 pcs;
- box size: 13,5 x 12,5 x 3 cm

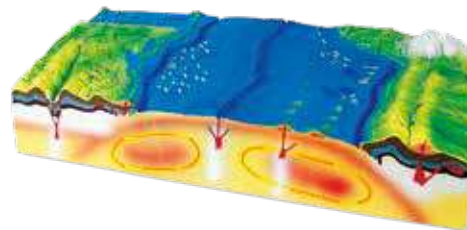

Model of modular makeup & earth terrain

QH0054

- size: 62,5 x 33,5 x 15 cm

MINERALS

Minerals set QH0039

- 42 pcs;
- in a plastic box

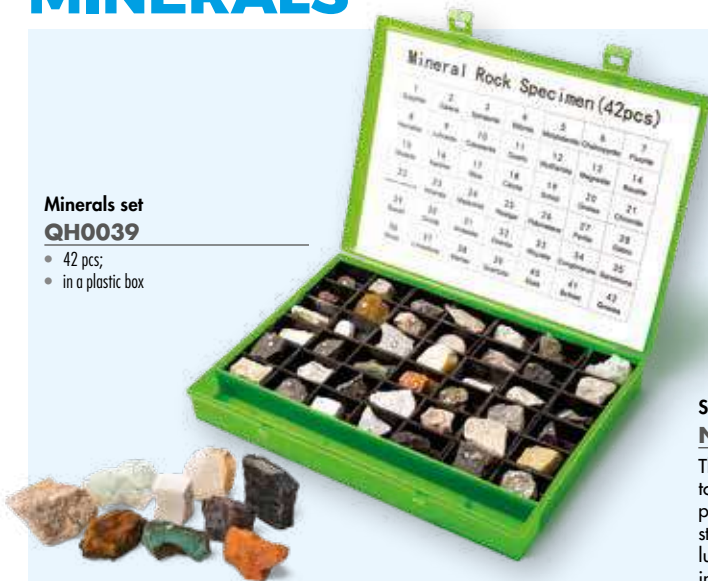

Set for testing minerals NS6142

This set contains the tools which help to conduct tests to determine the key properties of minerals. They allow the students to assess the hardness, striation, lustre and magnetism. The set also includes necessary information about

rock masses and tips for recognizing them. Thanks to this, students can take it out in the field and study the minerals themselves.

- 7 pcs: metal nail, 7 cm long, white ceramic tile, black ceramic tile, glass tile, neodymium magnet, magnifier, bottle with a dropper, 30 ml;
- age: 8+



WEATHER



Anemometer (digital) HG0004

An instrument for measuring the direction and strength of wind.

- measurement range: 0 - 30 m/s;
- size: 40 x 10 x 10 cm

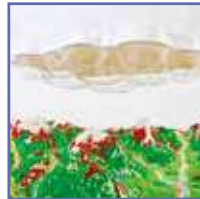

Hydrological cycle model VO5864

- set includes: a plastic container with a 3D terrain model, a cover, a prop, a cloud, instruction manual;
- size: 41,4 x 30 x 16 cm



Thermometer QH0003

A thermometer for fluids and solids.

- temperature range: -50 – 1200 °C



Rain Gauge IV8405

Precise measurement of precipitation. Scale in millimetres. Lid for safe transportation.

- size: 16 x 8 cm

ACCESSORIES & OBSERVATIONS



Telescopic net
QH0059

- length 1,0 cm, ø 35 cm;
- telescopic handle



Net
QH0057

- net size: 24 x 34 x 60 cm

POSTERS



Solar System
NS1103

- Double-sided (in Polish and English).
- size: 100 x 70 cm



World Map of Nations
NS1104

- A map locating various nationalities featuring Children of the World handpuppets. Double-sided (in English and Polish).
- size: 100 x 70 cm

customizable
language



m

MICROSCOPES

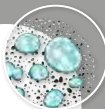

BIOLOGICAL AIDS

The microscopic world is a mysterious and fascinating environment rich in live organisms invisible to the human eye. We can explore its nature thanks to microscopes – a product of the human mind. To help children watch the microscopic world, we offer best-quality digital and optical microscopes for use at schools, colleges and laboratories. Some of them can be used out in the field. All of them are best-quality products with very good optical parameters. Our offer meets the needs of various users and various

tasks. The simple versions are intended for children and aim to get them interested in science. The classical models are for pupils who have just started their adventure with biology in primary school. The advanced microscopes will best serve in situations where high precision and picture quality are a priority. The offer is complemented by an array of accessories, such as slides coverslips, preparatory devices, ready-to-use biological preparations and image-recording devices, i.e. camera.



D

frame



head

eyepiece
/screendigital
camera

X



E

coarse and fine
adjustment

B



C

objective
lenses / zoom

G

condenser



digital camera magnification scales

top
light

H

bottom
light

electric power



J



base



K



L

specimen
holder

F

stage

specifications

DIGITAL LCD

5 Mpix.

(12 mpix interpolated)



10x-300x
(1200x digital)

MX0061

- A** 3,5" LCD colourful display
- C** Zoom: x 20-500
- E** Manual focus adjustment : 0 – 150 mm
- F** Specimen holder with metal
- D** Metal
- G** Lighting: 8 white light LED
- J** Power: 200 V / 5V, 50 Hz, AC; 5V, 1A output, Lithium – ion battery 3,7 V/1050 mAh, Battery lifespan: 2 hours, charging: 2 hours,
- K** Metal
- X** 5 megapixels (interpolation up to 12), Video recording: yes, Frame rate: 30 frames per second (FPS), Image format*: .jpg, Software: 2.0 USB driver, image and video processing software with measurements function, USB 2.0 computer interface, System requirements: Windows XP SP2/Vista/7/8/10, Mac 10.6-10.10; 2.0 USB port, CD recorder, Intended use: General use Can be used by children over the age 3, Additional device connection available, MicroSD card supports up to 32 GB (cards not included), Software language: English, german, russian, french, spanish, italian, dutch, polish, portuguese, chinese, korean, japanese, Video format: avi, Max resolution: 12 Mpx, 8 Mpx, 5 Mpx, 3 Mpx, 1,3 Mpx, VGA

Additional information:

- weight.: 0,76kg (with battery);
- size.: 22,7x10,4x14,9 cm;
- compatible with Windows and Mac OS systems;
- set contains: microscope, adapter, lithium-ion battery, USB cable, AV cable, Cleaning cloth, Calibrating scale, Image processing software, User manual and warranty card;
- software usage recommendations: for the software to work properly, start the application only when the microscope is connected to the computer and ready for use;
- microscope is not compatible with external digital cameras



BINOCULAR



100x-1000x



MX0063

- A** Eyepiece WF10X
- B** Binocular 45° Inclined Rotatable 360°
- C** Achromatic objectives 10X, 40X, 100X OIL
- D** Metal
- E** Coarse adjustment range 1,3 mm
Fine adjustment 22 mm
- F** Stage size 120 x 120 mm
- G** NA1,25 Abbe condenser
- H** Bottom halogen lamp
- J** A/C
- K** Metal
- L** Moving ruler
- X** Digital camera compatible

MONOCULAR MICROSCOPES



MX0080

- A** Eyepiece WF16X
- B** Monocular 45° Inclined Rotatable 360°
- C** Objectives 4X, 10X, 40X
- D** Metal
- E** Coarse adjustment range 8 mm
- F** Stage size 90 x 90 mm
- G** NA0,65 condenser with color filter
- H** Top and bottom holagen light
- J** A/C + 3 Batteries AA
- K** Metal
- L** Movable specimen holder X-Y
- X** Digital camera compatible



MX0044

- A** Eyepiece WF10X
- B** Monocular 45° Inclined Rotatable 360°
- C** Objectives 4X, 10X, 40X
- D** Metal
- E** Coarse and fine adjustment range 8 mm
- F** Stage size 90 x 90 mm
- G** NA0,65 condenser with color filter
- H** Top and bottom holagen lamp
- J** A/C + 4 Batteries AA
- K** Metal
- L** Moving ruler
- X** Digital camera compatible

40x-400x



SETS



40x-1280x

MX0060

- A** WF 10X/16X 2X Barlow lens
- B** Monocular rotatable 360° inclined 45°
- C** Objectives 4x, 10x, 40x
- D** Metal
- E** Coarse adjustment range 8 mm
- F** Stage size 90 x 90 mm
- H** Top and bottom light
- J** A/C + 3 x Batteries AA
- K** Metal
- L** Movable specimen holder X-Y
- X** Digital USB camera 0.1 Mpix included

ACCESSORIES

- 1 plastic case
- torch (2 AAA batteries)
- tweezers
- Petri dishes
- USB camera
- filter wheel
- thickener
- ready-to-use specimen in plastic case (bottle of sea salt, rubber utensils, eosin stain, brine shrimps eggs)



MX0008

- A** Eyepiece WF16X
- B** Monocular 45° Inclined Rotatable 360°
- C** Objectives 4X, 10X, 40X
- D** Metal
- E** Coarse adjustment range 8 mm
- F** Stage size 90 x 90 mm
- G** NA0,65 condenser with color filter
- H** Top and bottom halogen lamp
- J** A/C + 3 Batteries AA
- K** Metal
- L** Movable specimen holder X-Y
- X** Digital camera compatible

**ACCESSORIES**

- 1 plastic case (with 5 pcs blank slides, 5 pcs prepared slides + 10 pcs cover glasses),
- pipette,
- stirring
- rod,
- tweezers,
- petri dish,
- specimen slicer,
- 1 bottle sea salt,
- gum media,
- eosin dye,
- brine shrimp eggs



PORTABLE MICROSCOPES



50x-500x
(1200x digital)

5 Mpix.

(12 mpix interpolated)



8 white light LED diodes



MX0902

- Optical system made of glass;
- Zoom: x 20 – 500 , up to 1200 x digitally;
- Manual focus adjustment : 0 – 30 mm;
- Lighting: 8 white light LED diodes;
- Power: 220 V / 5V, 50 Hz, AC; 5V, 1 A output, Lithium – ion battery 3,7 V/1050 mAh, Battery lifespan: 4 hours, charging: 5 hours;
- 5 megapixels (12 interpolated);
- Video recording: yes;
- Frames per second (FPS):30;
- image format: *.jpg;
- Video format: *.avi;
- Software: 2.0 USB driver, image and video processing software with measurement function;
- USB 2.0 computer interface;
- System requirements: Windows XP SP2/Vista/7/8/10, Mac 10.6-10.10; 2.0 USB port, CD recorder;
- MicroSD card support up to 32 GB (cards not included);
- Software language: English, german, russian, french, spanish, italian, dutch, polish, portuguese, chinese, korean, japanese;
- Max resolution: 12 Mpx, 9 Mpx, 5 Mpx, 3 Mpx, 1,3 Mpx, VGA;
- 0,7 kg (with battery);
- size.: 33 x 7 x 15 cm;



MX8010

- C** Magnification 20x-40x
- D** Plastic
- H** Top and bottom light
- J** 3 Batteries LR43
- K** Plastic



MX0901

Package content:

- 1x USB Digital Microscope;
- 1x Microscope Stand;
- 1x Installation CD with Driver, Measurement, User Manual;
- 1x Quick Start Guide;
- 1x Calibration Ruler

Main Specification:

- Sensor: HD color CMOS sensor;
- Picture Resolution: Standard 640 x 480, Max 1600 x 1200 (2 Mpix);
- Video Resolution: Standard 640 x 480, Max 1600 x 1200 (2Mpix.);
- Focus Range: 8mm ~ Infinity (Model 1600X has only one focus 8 mm excluded);
- Digital Zoom: 6X;
- Magnification Range: 200X, 500X, 800X, 1000X, 1600X;
- Power Supply: USB Port (5V DC) USB 2.0 & USB 1.1 Compatible;
- Operation System: Windows XP/Vista//7/8 32bit and 64bit;
- Product dimension: 112 mm (L) X 33 mm (R);
- Product net weight: 180g



STEREOSCOPIC MICROSCOPES

MX0040



20x-40x

- A** WF 10x
- B** binocular, 45° tilt
- C** 2x i 4x
- D** Metal
- E** Coarse adjustment
- F** Specimen holder ø. 90 mm
- G** Light condenser NA 0,65 with filter wheel
- H** Lighting: LED reflected, transmitted
- J** Power: AC, 3 x AA
- K** Specimen holder from mat glass
- L** Spring holders



MX0020



20x

- A** Eyepiece WF10X
- B** Binocular 90°
- C** Objectives 2X
- D** Metal
- E** Coarse adjustment range 8 mm
- F** Stage ø 50 mm
- H** Light top
- J** 3 Batteries AA
- K** Metal
- L** Movable specimen holder X-Y
- X** Digital camera compatible



ACCESSORIES FOR MICROSCOPES

USB 2.0



CAMERAS

MX0045

2 Mpix.

Sensor size 1/3.2" (4,48 x 3,36 mm);
Pixel size 2,8 x 2,8 µm;
Framerate in resolutions 5@1600 x 1200 px,
7.5@1280 x 1024 px, 20@800 x 600 px.

MX0055

3 Mpix.

Sensor size 1/3"; (4,10 x 3,07 mm);
Pixel size 2 x 2 µm;
Framerate in resolutions: 20@2048 x 1536 px,
20@1600 x 1200 px, 30@800 x 600 px.

MX0065

5 Mpix.

Sensor size 1/2,7" (5,18 x 3,89 mm);
Pixel size 2 x 2 µm;
Framerate in resolutions 20@2592 x 1944 px,
20@2048 x 1536 px, 30@800 x 600 px.

Mounting diameter 23,2 mm
CD with software and drivers



Sets contents: MX0088

- 1 Eyedropper
- 1 Tweezer
- 1.6x Barrel Lenses
- 15 ready-to-view specimens
- 5 clear basic slides
- 1 Pre-treatment needle
- 1 Lockable tube
- 1 Stirrer
- 1 Sample container
- 1 Optics cleaning wipes
- 1 Labels for preparations.



MX0047

- 2 Simple preparation needle (black plastic handle, chromed steel)
- 1 Lanceolate needle (black plastic handle, chromed steel)
- 1 Steel tweezers with a sharp end (13 cm)
- 1 Steel tweezers finished blunt (13 cm)
- 1 Steel sectional scissors, pointed (11 cm)
- 1 Steel scalpel (handle for mounting blades)
- 5 Scalpel blades (for mounting in a scalpel holder)
- 2 Pasteur plastic pipette with a capacity of 1 cm
- 2 Plastic round bottom test tube with stopper
- The whole is in an aesthetic reinforced case closed with a zipper.



MX0048

- 1 Ready-made preparations (5 items),
- 1 Glass slides (5 items),
- 1 Coverslips (10 pcs),
- 1 Plastic box for preparations,
- 1 Plastic round container with lid,
- 1 Pipette,
- 1 Test-tube,
- 1 Preparation needle,
- 1 Special paper for cleaning the optics,
- 1 Tweezers,
- 1 Preparation stick,
- 1 Adhesive labels for labeling preparations,

MICROSCOPE SLIDES



in wooden boxes



Miscoscopes slides RV2016

Set of 55 microscopes slides with:

- epithelial, connective, nervous and muscular tissue - quantity: 5 pcs;
- epithelium of human skin - quantity: 5 pcs;
- bacterial cells (cocci, bacilli, spirilla) - quantity: 5 pcs;
- mitosis in cells of onion rootlets - quantity: 5 pcs;
- plant and animal cells; quantity - 5 pcs;
- human blood and blood frog- quantity: 5 pcs;
- Spirogyra; quantity - 5 pcs;
- longitudinal section of the stem of corn; quantity - 5 pcs;
- structure of the root - quantity: 5 pcs;
- hydra - quantity: 5 pcs;
- ciliate-shoes - quantity: 5 pcs
- age: 7+



Botanics MX2925

- a set of 25 slides, e.g.: corn, moss, lily, fern, cotton, silverberry, mulberry, pumpkin (stem)

Zoology MX1925

- a set of 25 slides, e.g.: hydra, ascaris lumbricoides, paramecium caudatum, fruit fly, silkworm, ant, dragonfly (wing), shrimp (antenna)

Human anatomy MX0009

- a set of 25 slides, e.g.: squamous epithelium, dense connective tissue, cardiac muscle, motor neuron

BOTANIC MODELS



Plant cell model
QH0012

- size: 30 x 20 x 51 cm

Chloroplast model
QH0007

One part removed for detailed presentation.

- size: H 30 cm, base ø 15 cm



Paramecium model
QH0006

- size: 38 x 9,5 x 20 cm;
- made of plastic, on a stand

Cell organs set
QH0008

- set includes: a chloroplast, mitochondrion, Golgi apparatus, the inside of a cell, the cell nucleus;
- size: 27 x 20 x 17 cm



VIRUS MODEL

- made of PVC;
- size: 20 x 15 x 8 cm

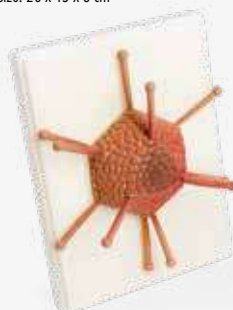

Adenovirus
QH0041



Bacteriophage
QH0042



HIV virus
QH0043



Tobacco
QH0044



Dicotyledonous stem model
QH0010

- size: 36 x 24 x 17 cm



Monocotyledonous stem model
QH0009

- size: 42 x 13 x 41 cm



Flower model
RV4018

- A model with removable petals.
- base size: 12 x 12 cm, H 21 cm



Wheat flower model
QH0045

- size: 9 x 16 x 29 cm



Root tip model
QH0011

- size: 12 x 12 x 35 cm



Root systems - 4 types (embedded in plexiglass)
HG0092

4 preparations embedded in a plexiglass present the types of root systems and their morphology and some modifications of this organ. It is an educational aid intended for biology lessons.

The set includes:

- 1. typical pile root system with a clearly dominant main root;
- 2. adventitious roots growing out of a plant stem;
- 3. roots with root nodules - these structures are inhabited by symbiotic bacteria for the plant;
- 4. fibrous root system consisting of many thin roots.



Specimen of wheat growth process
RV2017

- size: 16 x 7,5 x 2,5 cm; material: acryl; age: 7+



Bean Germination
HG0064

- size: 16 x 7,5 x 2,5 cm; material: acryl; age: 7+



Specimen of corn growth
RV1094

- size: 16 x 7,5 x 2,5 cm; material: acryl; age: 7+

BIOLOGICAL AIDS SETS



Animalia Kingdom. The suitcase with specimens, worksheets and lesson scenarios NS6114

The Science Suitcase with a rich collection of specimens of different species of the animal kingdom. Certain specimens of vertebrates and invertebrates were embedded in transparent acrylic blocks which allow the students to observe

them from every angle. Each animal was put in a separate block in order to facilitate careful observation and analysis of their most important features. Worksheets for students and lesson plans for the teacher complement the set.

- 20 specimens in a suitcase with dim.: 45,5 x 6 x 33 cm;
- 3 lesson scenarios, 24 bilateral worksheets, dim.: 11,5 x 11,5 cm;
- material: plastic; age: 6+



Kingdom of Plantae, Fungi and Algae. The suitcase with teaching aids, worksheets and lesson scenarios NS6112

The Science Suitcase with teaching aids such as different species of plants, fungi and protists embedded in transparent acrylic. These natural specimens can be observed from every angle. Additionally, with the use of magnifying glass, it is possible to see the smallest details.

The suitcase contains 9 blocks presenting 32 specimens of algae, fungi, bryophytes, ferns, gymnosperms and angiosperms, and the life cycle of moss and ferns. The set is also equipped with substantive materials for the teacher and students.

- dim. of the suitcase: 45,5 x 6 x 33 cm;
- 6 lesson scenarios, 24 bilateral worksheets, dim.: 11,5 x 11,5 cm;
- material: plastic; age: 6+



ANIMAL MODELS

Animal cell model QH0004

- size: 30 x 20 x 51 cm



Animal cell v plant cell. Comparison chart QH3228

The chart presents the structures of a plant cell and an animal cell. The size of the model, structural details and colours helps distinguish particular structures and determine common features and differences.

- size: 61,5 x 4 x 52 cm

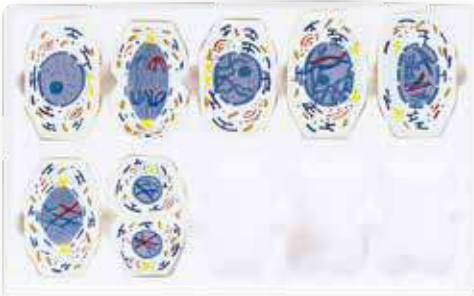
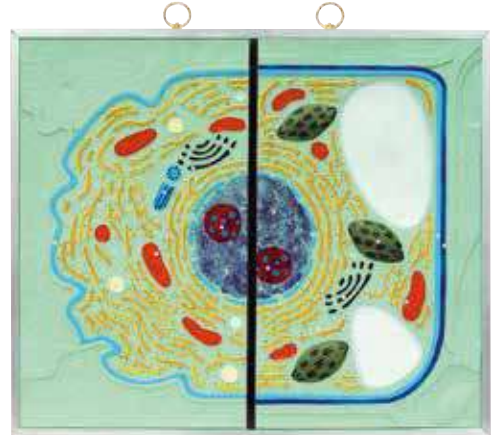

Meiosis and mitosis. Demonstration set QH0005

A plastic model of an animal cell.

- consists of two parts depicting meiosis and mitosis;
- size: 59 x 37 x 5 cm



The roundworm parasite HG0022

Natural specimens of an adult form of the human roundworm embedded in an acrylic block. It is possible to observe them from any angle and

to find and compare the characteristic features of the female and male representatives of these parasites.

- 7,3 x 4,1 x 2,4 cm; 2 specimens: adult, male and female specimen;
- material: acrylic; packaging: cardboard box



Life cycle of Grasshopper HG0046

The full life cycle of a Grasshopper in this 9 stage development specimen. The real life grasshoppers are encased in break proof acrylic.

- size: 16,5 x 8 x 2 cm;
- acrylic material

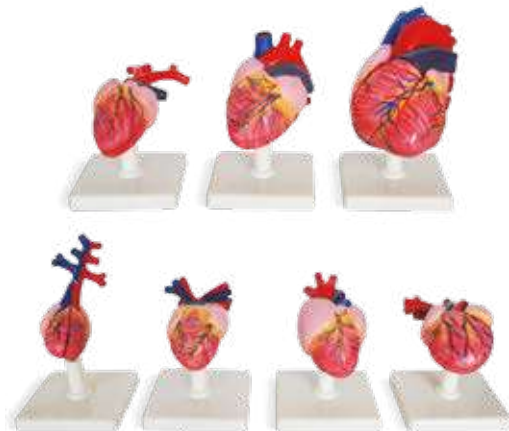

The evolution of vertebrates' hearts QH4108

Set of models which presents the evolution of vertebrate hearts. The size and colours of the specific elements allow the students to see the differences, similarities and evolutionary changes in the heart

structure of fish, amphibians, reptiles, mammals and reptiles. Each model is placed on a separate base which makes the observation easier.

- 7 heart models of the fish, frog, turtle, crocodile, bird, dog, human;
- weight of the set: 2,9 kg;
- material: plastic



The evolution of vertebrates encephalons QH4107

Set of comparative models which presents the evolution of vertebrates. The right selection of colours and the size of the organ makes it possible

to observe the anatomical details of the brain of different animals in the course of evolution. Each model is equipped with a separate stands.

- 8 models of the brains: river lamprey, trout, frog, alligator, pigeon, rabbit, dog;
- weight: 1,6 kg;
- material: plastic

CROSS-SECTION MODEL IN PLEXIGLASS

It is an excellent aid for biological classes - it illustrates how the complexity of this organ in a given animal reflects the stage of evolution. The transparent material allows for close observation, is safe for the pupil and extends the durability of the product.

Animals' brains UK0603

The model contains 5 brains encased in plexiglass: of a fish (carp), amphibian (frog), reptile (snake), bird (pigeon), mammal (rabbit).

- size: 16,4 x 7,8 x 2,4 cm

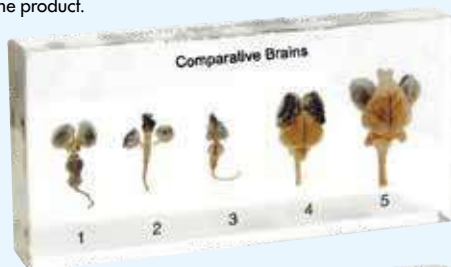

Animals' hearts UK0602

The set encased in plexiglass contains 5 hearts of: a fish (carp), amphibian (frog), reptile (snake), bird (pigeon), mammal (rabbit).

- size: 16 x 7,5 x 2,5 cm

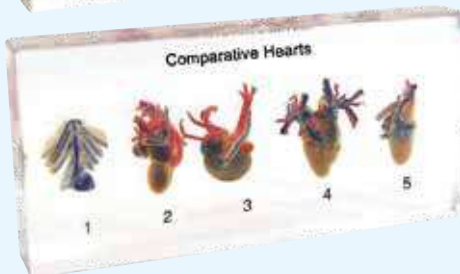

ANIMAL SKELETON

A plastic animal skeletons encased in plexiglass. Useful in biology classes.

- plastic eco
- acrylic glass case



Fish skeleton
RV3009

- size: 15 x 13 x 21 cm



Toad skeleton
RV3016

- size: 15 x 17,5 x 5,5 cm



Pigeon skeleton
RV3006

- size: 19,5 x 15,5 x 21 cm



Lizard skeleton
RV3017

- size: 23 x 10 x 6,5 cm



Rabbit skeleton
HG0017

- size: 37,5 x 18,5 x 13,5 cm

Plastic animal skeletons for observation and study. Durable, clear acrylic allows close up viewing from all angles. Acrylic block will not break even if it is accidentally dropped. Due to nature of the product it may differ slightly from the image shown.



Fish skeleton
HG0013

- size: 20 x 9 x 4 cm



Toad skeleton
HG0014

- size: 13,5 x 9 x 3,5 cm



Turtle Skeleton
HG0016

- size: 13,5 x 9 x 2,4 cm



Lizard Skeleton
HG0009

- size: 16,5 x 2 x 8 cm



Pigeon skeleton
HG0010

- size: 18 x 14 x 8 cm



Rabbit skeleton
HG0015

- size: 20 x 9 x 4 cm



Rat skeleton
HG0012

- size: 20 x 9 x 4 cm

MODELS OF HUMAN ORGANS



Human skeleton. Model
BD5302

- life-sized (H 1,0 cm);
- made of plastic;
- metal stand with castors



Model of human skeleton left painted
QH3302

Muscle origins are marked in red and insertions in blue.

- made of plastic and fixed, on a mobile stand;
- need assembly; life-sized (H 1,0 cm)



Small human skeleton.

Model
VO6188

- easy - to - join plastic elements;
- H 80 cm



Human vertebral column and pelvis.

Model
QH0022

- life-sized (25 x 14 x 66 cm);
- flexible





Bone structure. 3D board
HG0001

The board consists of 4 elements: periosteum, blood vessels, cancellous bone, cortical bone.

- size: 53 x 38 x 8 cm; made of PVC; hand-painted



Skull model
HG0041

A skull model with a mobile mandible and removable elements.

- size: 22 x 14 x 16 cm; weight 950g

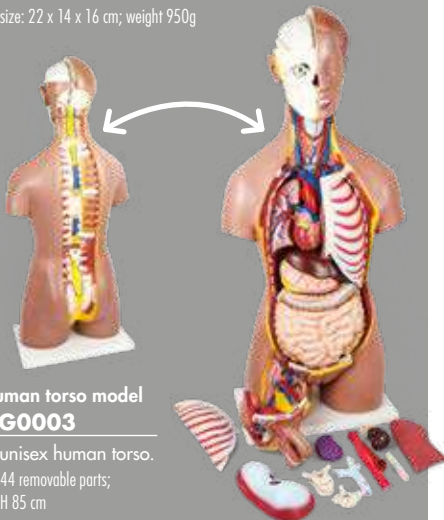

Human torso model
HG0003

A unisex human torso.

- 44 removable parts;
- H 85 cm



DNA comparative model
RV4013

Model on a metal stand. Colourful elements represent different parts of the DNA structure. It is a perfect set for making a double helix and learning about the replication process. The aid is equipped with a stable, metal stand.

- 6 types of elements;
- dim.: 12 x 12 x 38 cm



DNA model
RV4011

A model depicting DNA segments: cytosine, guanine, adenine, and thymine. It can be helpful in presenting the chemical and spatial structure of the DNA chain, the differences between nucleosides and nucleotides or explaining the principle of DNA complementarity as well as that of DNA replication and transcription. This aid is equipped with a stable stand.

- dim.: 12 x 12 x 46 cm;
- material: plastic

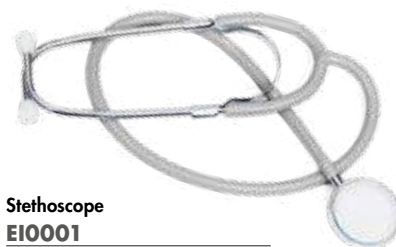

Stethoscope
EI0001

- made of metal; L 75 cm

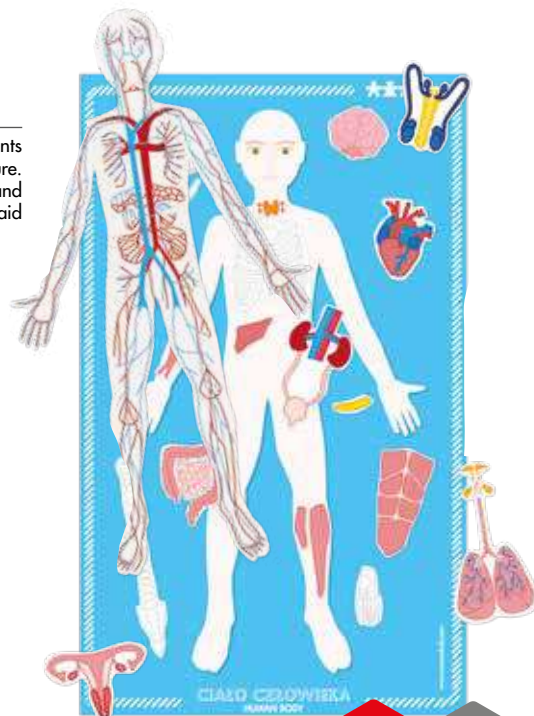

Human body. Magnetic board
NS1364

An educational toy, that helps gain knowledge concerning the structure of human body. The task is to assemble a diagram of each of the systems of human body (bone, muscular, respiratory, digestive, endocrine, urogenital and circulatory system).

Set includes:

- 1 big magnetic board 100 x 60 cm;
- 16 magnets with names of human body systems (in english and polish);
- 69 magnets with depictions of human body parts; box, manual



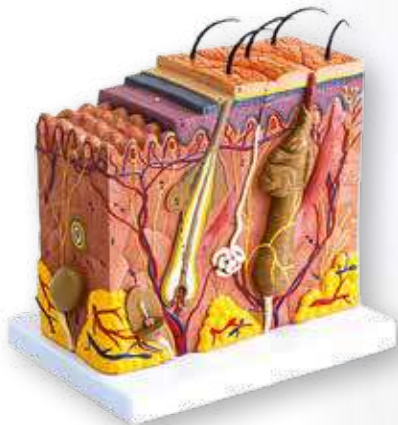

Human skin model
RV3132

A cross-section model representing in microscopic detail the structure of human skin.

- size: 11,5 x 22 x 21 cm;
- scale 70:1

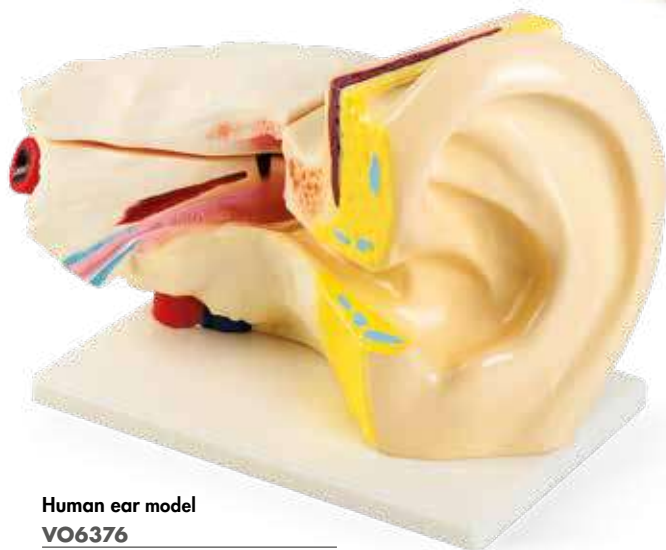

Human ear model
VO6376

- scale 5:1;
- size: 44 x 14 x 20 cm



Human eye model
VO6192

- 6 mobile elements;
- on a stand;
- ø 16 cm, H 21 cm



Spinal cord with nerves QH3308

A teaching aid to show how the reflex arc works i.e. the way of a nerve impulse from the receptor to the sensory neuron to the control centre to the motor neuron to the effector muscle. Made of plastic, it is a great help in biology lessons.

- panel size: 42 x 4,5 x 30 cm



Reflex arc - cross-section model TS15411

A panel with a schematic representation of the reflex arc made of high-quality materials. An excellent aid for middle or secondary school biology lessons. The model shows the working of the receptor, sensory neuron, internuncial neuron, motor neuron and effector.

- size: 42 x 30 x 6 cm;
- elements made of PVC, panel made of ABS



Oral hygiene model VO5456

- 7 cm



Tooth pathology QH3353

Bilateral model presenting the structure of the tooth, gums and jaws and typical pathologies such as: caries, cracked tooth, periodontitis, plaque and others. It is a perfect visual aid for teaching oral hygiene. This model is mounted on a stable base with rubber feet. The product is available with a board describing the model.

- 16,5 x 12 x 18,5 cm; material: plastic.



Human brain with arteries. Anatomical model AM1414

See how the brain is built and learn about its functions.

- life-sized; made of plastic



Neuron model
QH0020

- size: 36 x 23 x 10 cm



Blood circulation system 3D board
QH0017

- size: 30 x 80 x 6 cm



Head cross-section with the muscular and vascular-nervous systems
HG0155

This model presents a lateral section of a life-size human head. It illustrates the external and internal structure of the head and neck, along with the muscular and circulatory system. Each anatomical structure was marked with a specific colour and number to facilitate their location and arrangement. The model is very detailed and therefore perfect for high school students and medical students. The product is delivered on a stand.

- size: 27 x 10 x 22 cm; material: plastic



Artery structure model
QH0013

- scale 100:1;
- on a stand

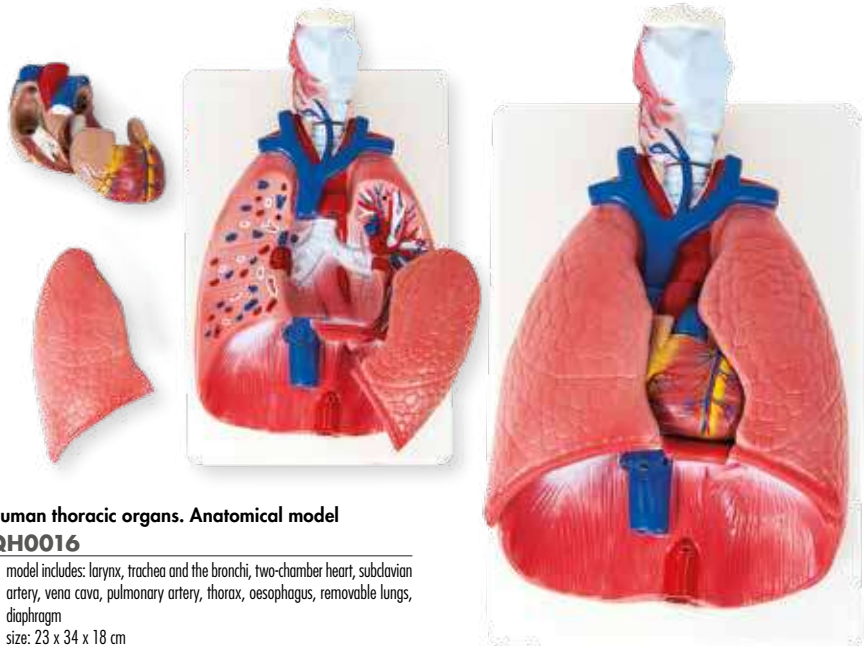

Human thoracic organs. Anatomical model
QH0016

- model includes: larynx, trachea and the bronchi, two-chamber heart, subclavian artery, vena cava, pulmonary artery, thorax, oesophagus, removable lungs, diaphragm
- size: 23 x 34 x 18 cm

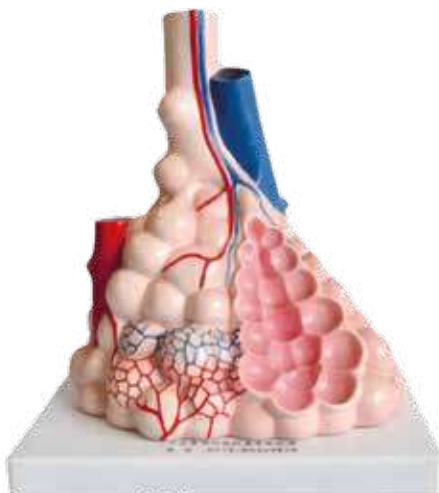

Pulmonary alveoli
QH3306

A model of part of a pulmonary lobe showing the alveoli. It will come in useful in secondary school biology classes. It shows all the anatomical details of pulmonary alveoli and bronchioli, as well as of capillary vessels, arterioles and veins.

- size: 21 x 15 x 23 cm



Lung demonstration model
AM7120

An aid to explain how lungs get filled and emptied of air thanks to the diaphragm.

- set includes: a plastic jar (ø 20 cm), a rubber disc, 2 balloons



Muscles of human body. Model
QH0048

A general model of human muscular system.

- size: 20 x 17 x 85 cm

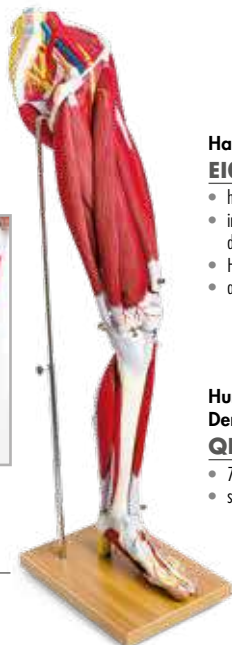

Human leg muscular system.
Demonstration model
QH0023

- 23 pcs;
- on stand;
- life sized



Hand model
EI0014

- highly detailed finish;
- includes: 23 pieces, display stand, manual;
- H 16,5 cm;
- age: 8+

Human arm muscular system.
Demonstration model
QH0024

- 7 pcs;
- size: 70 x 30 x 32 cm

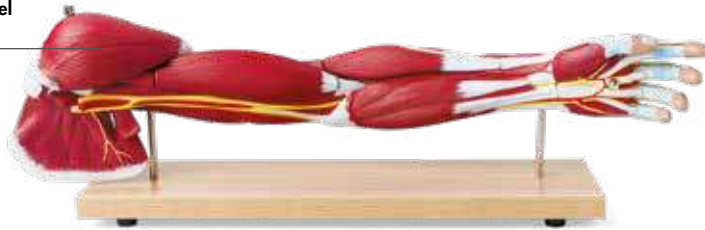



**Human stomach.
Model**
QH0047

- size: 12 x 12 x 18 cm;
- 2 pcs



**Human liver, pancreas and duodenum.
Anatomical model**
QH0015

- size: 17 x 17 x 22 cm



Female pelvis
HG0452

Three-piece, life-size model in sagittal section which presents female reproductive organs, urinary bladder and rectum. The internal structure of the genitourinary system is very detailed and it is possible to easily locate the uterus, vagina, bladder and urethra, labia, pubic symphysis and rectum. Removable parts in the form of a female reproductive system with a semi-open uterus allow the students to see the anatomical details of the internal structure. The model is placed on the base. The description of the numbered elements can be found in the manual.

- size: 33 x 23 x 30 cm; material: plastic



Male pelvis
HG0451

This spatial model presents cross-section along the median plane of the male pelvis with all its important structures. It includes: internal and external genitalia, urinary bladder, rectum and a section of the spine with the tail bone. Muscles and blood vessels are marked with appropriate colours. Behind the removable part of the model we can see more anatomical details. A stable base ensures comfortable presentation of all the elements. The description of the numbered elements can be found in the manual.

- size: 30 x 20 x 28 cm; material: plastic



Digestive system. 3D board**QH0018**

- size: 30 x 80 x 6 cm

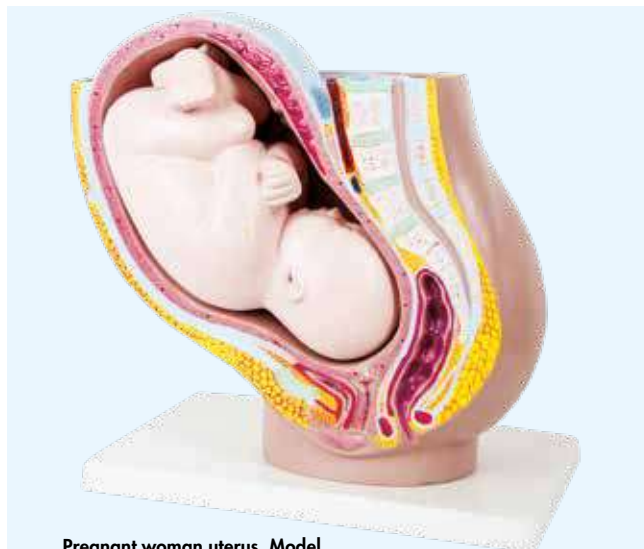
**Pregnant woman uterus. Model****QH0021**

A two-part cross-section model of a uterus in the 40th week of pregnancy.

- size: 40 x 26 x 34 cm

Human urinary system. Unisex model**QH0014**

- 3 pcs;
- size: 21 x 13 x 35 cm

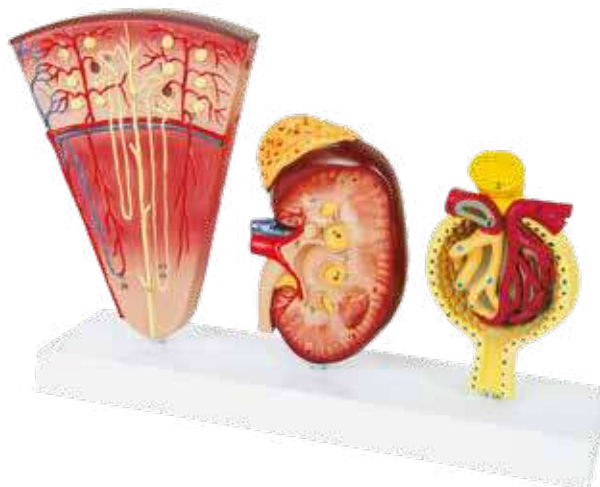
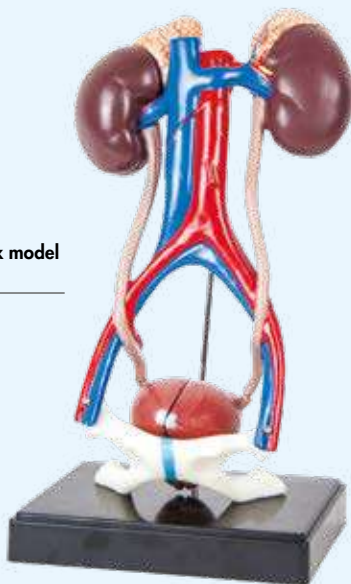
**Kidney nefron and glomerulus. Anatomical model****HG0002**

- mounted on a flat base;
- includes 3 specific elements: kidney (9,5 x 14 cm), glomerule (8 x 14 cm), nephron (15,5 x 19 cm)

ECOLOGY



Renewable energy set IV7059

The set demonstrates different ways in which energy can be produced. With this aid, it is possible to compare the effectiveness of various sources, like water, wind, and sun on 4 devices: a bell, a light meter, and a turbine. The

portable device is easy to assemble. The set includes 4 interchangeable boards used for monitoring the generated energy. Suitable for inside and outside use.

- 1x wind turbine; 1x water turbine; 1x tube; 1x solar panel; 1x universal stand; 1x universal mast; power meter, light indicator, bell, motion indicator (gear);
- height: 38 cm; material plastic; age: 7+

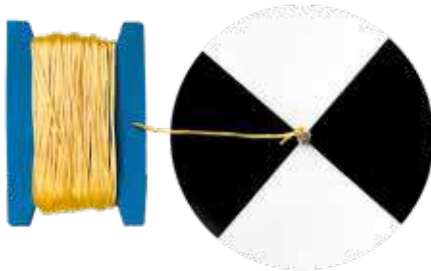

Secchi disc RV3087

A disk which can be used to monitor the water quality and photosynthesis process as part of ecological research. The size of the disk allows students to work in small groups.

- disk diameter: 19 cm; string's length: 1m; age: 8+



Water Filtration Kit E10055

The kit here introduces how water gets cleaned by building a simple filtration system and more...

- set includes: 6 x filtration paper, 2 sponges, 1 x crushed granite, 1 x porcelain sand, 1 x activated carbon, 1 x quartz sand, 1 x saleratus, 1 x potassium alum, 1 x plastic hopper, 1 x plastic cover, 4 x filtration tube



Waste segregation. Wooden puzzle VG4504

Educational toy for learning how to segregate waste and for raising environmental awareness. This product has a form of a box-shaped sorter with 4 holes, where properly segregated waste should be placed. The examples of rubbish for segregation are shown on wooden tiles. To check if the task was done correctly, the colour of the container is printed on the back of each tile. The set includes dices which randomly indicate the colour, with which the container should be filled.

- 13 pcs: 8 tiles with illustrations, 1 box
- 29,5 x 12 x 8,3 cm, 1 board illustrating the containers, 1 board with holes, 2 dices;
- weight: 0,9 kg; material: wood; age: 3 +

CHEMICAL AIDS

SETS

Lab desks available in furniture section page 264



Synthetic materials – 8 types in acrylic
HG0112

Set of 8 pieces of different materials embedded in acrylic blocks. The individual samples were placed in transparent material in order to view the samples comfortably without fear of damaging them. The students can see up close the characteristic features of each material. There are 8 elements in the acrylic bar: ceramics, metal, glass, MDF, plastic, paper, cloth, cement.

- size.: 14 x 6 x 1,5 cm

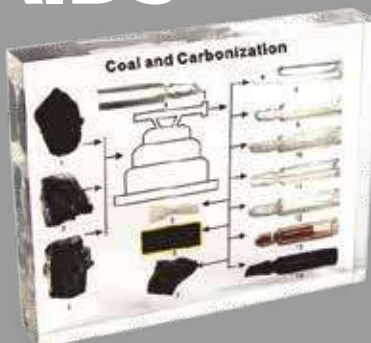

Coal - sources and products of its processing (plexiglass)
HG0122

This set presents main sources of coal and products of its processing. Small fragments of fossil coal embedded in the plexiglass, such as: lignite, hard coal, anthracite and samples of materials which can be formed by them during pyrolysis or chemical treatment processes (gas, carbon fiber, coke, ammonia, naphthalene, fertilizers, pesticides, drugs, dyes and which is often added in the production of rubber as an ingredient that reduces its hardness in the vulcanized state).

- size.: 18 x 3,5 x 2,5 cm



Petroleum - distillation and products (plexiglass)
HG0121

Crude oil distillation and its products. The set contains small samples of crude oil and its derivatives formed during distillation in CDU / VDU units (atmospheric and vacuum distillation). Inside the transparent plexiglass, it is possible to see the samples of crude oil and its derivatives. The diagrams connecting the samples provide information not only about the distillation process which formed them, but also the relative volatility of the distillates.

- size.: 18 x 14 x 2,5 cm



Simple substance
RV0304

Set includes: S, C, Cu, Al., Zn, Fe, Pb, Mg, Ca, SiO₂, C₆H₆, crystal iodine

- size of box: 30 x 21 x 15 cm



ATOMS



3D atom model

TS16612

- made of plastic;
- size: atom ø 39 cm, H 42 cm



Structure of atom - set

TS18056

A magnetic set to construct models of atoms, isotopes and ions.

- disc ø 20 cm; 20 atoms, 20 isotopes, 20 ions

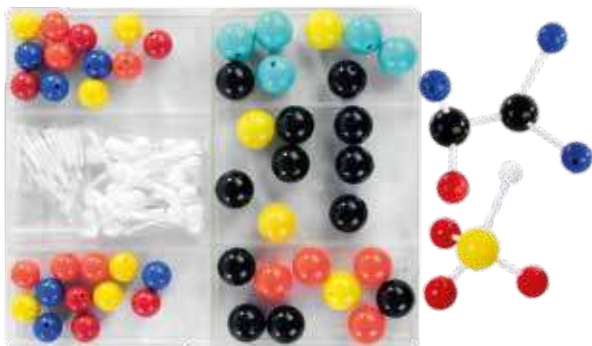

Molecular model student set basic

AM1864

104 elements. Set includes:

- 6 - 2,5 cm black alkane carbon balls;
- 4 - 2,5 cm black alkene carbon balls;
- 2 - 2,5 cm black alkyne carbon balls;
- 5 - 2,5 cm green halogens & monovalent non-metals balls;
- 4 - 2,5 cm yellow sulfur/selenium hexavalent balls;
- 4 - 2,5 cm orange sodium/potassium monovalent metals balls;
- 6 - 2 cm red oxygen balls;
- 6 - 2 cm blue nitrogen/phosphorous trivalent & pentavalent element balls;
- 6 - 2 cm yellow aluminum/chromium trivalent metals balls;
- 6 - 2 cm orange calcium/magnesium bivalent metals balls;
- 25 - 1 cm white hydrogen balls with integral bonding lugs;
- 30 - 1 cm bonding lugs

Model of molecular structure

QH0026

- 150 pcs;
- in a plastic box



Worksheets for Molecular

structures

QH0026W

- 24 pcs;
- size: 11,5 x 11,5 cm in a box



MODELS



Graphite model
HG1040

This set helps to create a three-layer graphite model with 15 carbon atoms in each layer. The diameter of atomic parts varies from 14,5–15 mm. Thanks to the molecular graphite model, students can easily learn about the molecular structure.

- The set includes: 45 carbon, black, dia. 23 mm;
- 51 grey bonds;
- 16 purple bonds

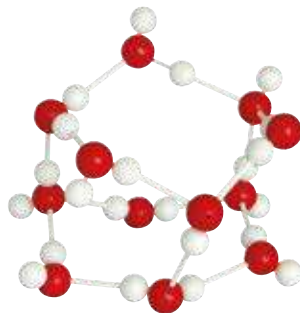

Ice model (water)
QH3331

Set presenting the molecular structure of ice. It contains molecular models of the ice structure which can be built with 78 atom parts. Thanks to this set, students can easily learn about the molecular structure of ice. The diameter of atomic parts varies from 14,5–15 mm.

- The set includes: 26 x red oxygen atom;
- 52 x white hydrogen atom;
- 52 x white covalent bond; 40 x purple hydrogen



Diamond crystal model
HG1038

A three-dimensional model of the characteristic crystal diamond structure. The molecular model of the Diamond is an excellent teaching aid for chemistry.



Sodium chloride model
HG1031

This molecular model presents the structure of sodium chloride molecules.

- the set contains the following models of the particles: 13 sodium atoms, grey, dia. 23 mm, 14 chlorine atoms, green, dia. 32 mm, 54 medium bonds

TUBES

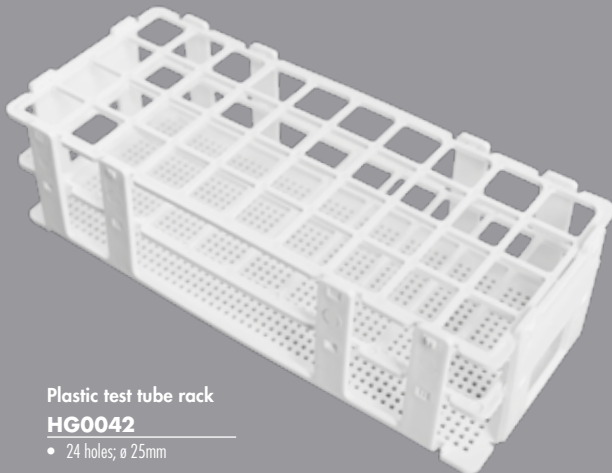

Plastic test tube rack
HG0042

- 24 holes; ø 25mm

Plastic test tube rack
HG0019

- 40 holes; ø 20 mm

Plastic test tube rack
HG0039

- 60 holes; ø 16mm



Round-bottom bacteriological test tube
TS30150

- D 16 mm, H 180 mm;
- made of borosilicate glass;
- round bottom and polished edges



Experimental 24 test tubes
TY3950

- 24 pcs, 12 ml;
- size: 9,5 x 1,5 cm;
- made of plastic

ACCESSORIES



Set of beakers

IV4359

The set consists of beakers of different volumes. They each have a cutout to allow excess liquid to drain off and ensure accurate measurement. They are made of resilient yet sturdy material which withstands larger load e.g. sand. The handles are wide for stable carrying.

- 4 pieces of volumes: 1,5 cm³, 2,0 cm³, 5,0 cm³, 1 l;
- material: plastic; colour: white



Measure beakers

TY7160

- 5 pcs: 1000 ml, 500 ml, 250 ml, 100 ml, 50 ml;
- made of plastic



Set of 1 l beakers of irregular shapes

IV1959

A set of 3 containers of 1 l each and of untypical shapes as an addition to item IV1205. They help extend the knowledge about volume. The beakers are funnel-shaped, triangular and elliptic. All are graduated.

- 3 elements of 1 l each;
- package size: 40 x 15,5 x 14,5 cm



Cube bag + liter cube

TY8401

- 1 l; 1 pc



Measuring cylinders

VO8543

- 7 pcs with capacity from 10 ml (10: 5 ml) to 1000 ml (1000: 10 ml);
- made of plastic



not acid resistant

Dissecting dish

HG1910

- size: 26 x 19 x 2 cm;
- with wax



Ceramic tiles – 12 dimples
HG1001

Porcelain tile with 12 dimples for serological testing and chemical analysis



Biology lab kit
QH2078

A kit for preparing microscope slides and taking samples. A 13,5 cm dissecting needle included.



Hydrometer set
HG0029

Set of 5 hydrometers of ranges:

- 0.700-0.800 g/cm³
- 0.800-0.900 g/cm³
- 0.900-1.000 g/cm³
- 1.000-1.100 g/cm³
- 1.100-1.200 g/cm³



Stand with handles
QH0025

- the stand consists of: the base, rod, large ring, small ring, 2 test tube clamps, 2 vertical clamps, 1 horizontal clamp



Liquids experiment. Convection tubes
QH2264

A glass tube bent into rectangle and fitted with a filling funnel for demonstration of convection in liquids.

- 3 pcs; size: 15,5 x 15,5; ø 1,2 cm;
- 15,5 x 24; ø 4 cm;
- 14,5 x 23,5; ø 1,4 cm



Preparation needle
TS14735

- A dissecting needle made of stainless steel and with an aluminium non-slip handle.
- total length 15 cm



Instrument cart
QH0027

- 2-storey;
- wheels with 2 brakes;
- made of stainless steel;
- size: 80 x 72 cm;
- shelf size: 36 x 67 cm



PHYSICAL AIDS SETS

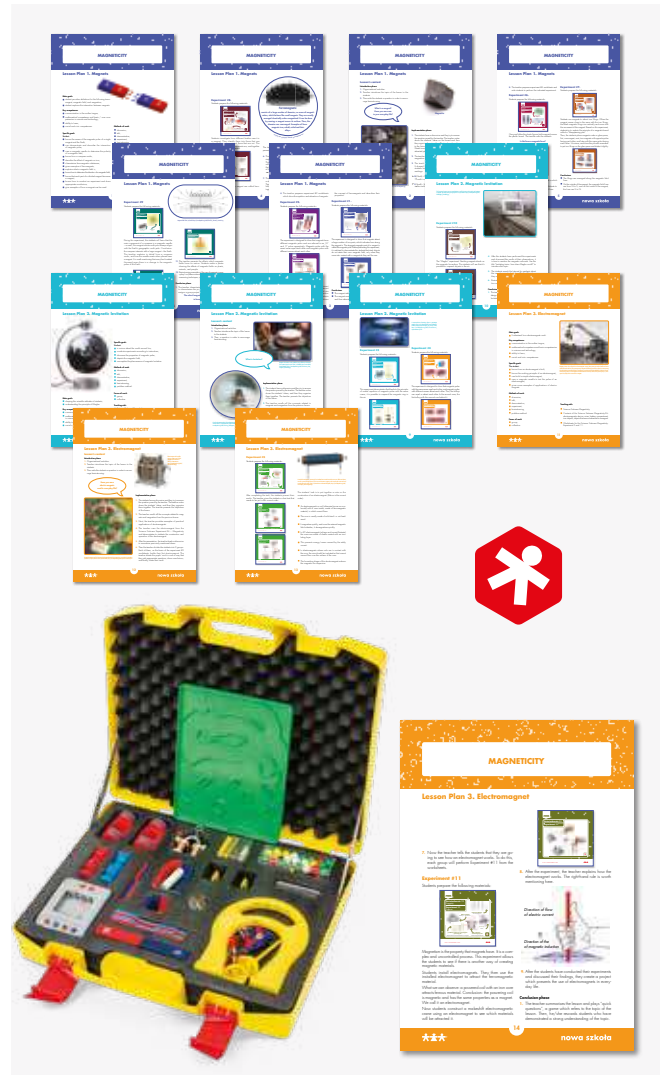

Magnetism. Science suitcase with lesson scenarios and worksheets NS6119

The contents of the suitcase allow students to conduct simple experiments in the field of magnetism. With this set, it is possible to build electromagnets, test magnetic properties of different materials or to

demonstrate how magnets and magnetic fields work. The teacher can also prepare an experiment which shows magnetic levitation. The lessons scenarios included in the set contain goals, methods, forms and a detailed lesson plan involving various interesting activities. The worksheets make conducting the experiments much easier thanks to the clear instructions.

Electricity. The Science Suitcase with worksheets and lesson scenarios NS6117

The contents of this suitcase help to conducting basic experiments in the field of electricity. Students have the possibility to construct electrical circuits; and test conductivity of various materials. The set also permits to demonstrate the transfer of electric charges and compare the electrostatic properties of bodies. Additionally, lesson scenarios and worksheets were added to facilitate the use of this set.

- electric bell with wires;
- fruit powered generator; manual generator;
- wires with banana plugs;
- a piece of fur;
- 2 x rubber sticks; silk; 2 x glass sticks, an electrical device responding to the human body; electric heater; crocodile clips with banana plugs; tiles made of: copper, iron, aluminium, plastic, wood, rubber; bulb holder, electric circuit test button; connection sockets; battery case; 3 switches; 2 x batteries; lightbulb; swivel bracket;
- 4 lesson scenarios;
- 24 worksheets, dim.: 11,5 x 11,5 cm;
- dim. of the suitcase: 55 x 15,5 x 46 cm;
- age: 8+



4 lesson scenarios

24 worksheets

Optics. The Science Suitcase with worksheets and lesson scenarios NS6118

Professional set for young explorers of the light's nature and basic issues in optics. The proposed experiments show the laws concerning the emission of light, its propagation and interaction with matter. The substantive materials for the teacher and students help to use the set.

- 4 lenses; convex mirror, concave mirror, a laser;
- 3 x flange;
- battery;
- candlestick, candle, battery case; laser stand, plastic graduated container, charger, wires with ends, optical bench, white screen bracket, base; flash light, white screen, mirror on plastic stands; solids (sphere, cylinder, pyramid, regular pyramid, cone, cuboid);
- 4 lesson scenarios;
- 4 worksheets, dim.: 11,5 x 11,5 cm;
- dim. of the suitcase: 55 x 15,5 x 46 cm;
- age: 6+



24 worksheets



Fuel samples

HG1016

Inside this aesthetic, wooden box are kept the models and samples showing fuels used in today's industry.

- case: 30 x 21 x 5 cm



Metals and their alloys in a suitcase

HG0024

Rich collection of samples of metals and their alloys which can be particularly useful during biology or chemistry classes. All samples are kept in a comfortable, wooden suitcase.

- suitcase: 30,5 x 20,5 x 5 cm;
- 12 plates: Fe (C2-4.3%), Fe, Fe (C<2), Fe - stainless steel, Cu – red copper;
- Cu, Pb, Al, Sn, Cu, Fe, Ni-Cr



Measurement of size and density

NS6140

This set was designed in order to introduce the basics of measuring a specific physical quantity based on observation and practical activities. It helps to understand and consolidate the terms related to the concepts of measure and density. The set is complemented by substantive instruction with the suggestions of different experiments and exercises.

- ruler, string, scissors, millimetre paper, wooden blocks, plexiglass blocks, wooden unit cubes, measuring cylinders, beakers, plasticine, balloon, scales, mass elements, set of cubes for density determination and others; age: 11+



MEASUREMENTS



Density blocks with hooks
HG0410

A set of cubes of equal volume made of different metals and alloys eg. Copper, brass, lead, zinc, steel, aluminium.

- cube side: 3,2 cm

The equal mass set
AM1323

The equal mass set contains samples of:

- aluminum (14 x 121 mm, 52 g);
- brass (14 x 38 mm, 48 g);
- stainless steel (14 x 41 mm, 50 g);
- copper (14 x 37 mm, 50 g);
- iron (14 x 41 mm, 50 g)

Vernier calliper
QH0001

- a traditional 150 mm calliper



Digital calliper
QH0002

- an electronic 150 mm calliper



Dynamometer 1N
AM0704

- 0 – 1N



Dynamometers
QH0036

- 3 pcs: 1N, 5N, 10N in red, green and black



Dynamometer 5N
QH1035

Dynamometer 10N
QH1040



Dynamometer 100N
HG0098

It consists of a transparent plastic tube with a spring and a scale in newtons (0 - 100)

- length 25 cm

FORCE AND MOTION

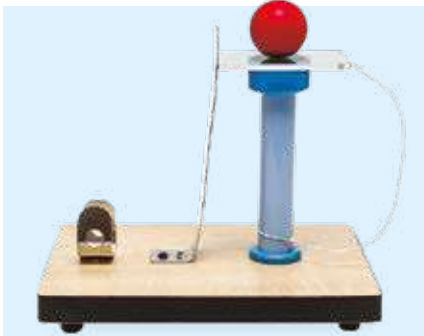

A device for demonstrating the inertia of bodies
HG0106

Rest the plastic ball on top of the plexiglass square which is placed on a vertical post. Release the spring and square shoots. The ball falls into the concave recession on the post and stays at rest on the top of it, as if nothing had happened.

- replaced 7-1977,5 „x 5,5“ „x 6,5“ , 0,9;
- lb.battery-powered (battery not included)

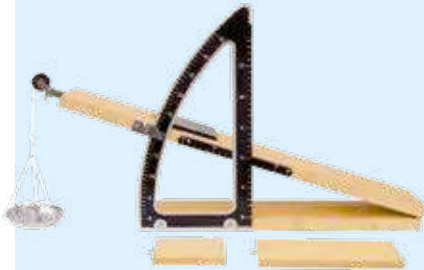

Friction on an Inclined plane
HG0740

This wooden inclined plane with adjustable tilt angle has a metal pulley at the upper end which holds a metal pan for weights. The weights exert a force on the body on the plane. The attached protractor has two scales (in degrees and centimetres) for measurements. Experiments with three kinds of blocks (of different size, weight and surface) help demonstrate how these affect the movement of blocks depends on the tilt and weights on the pan.

- 2 wooden boards, 1 metal pulley, 1 metal pan, 1 hook

Mechanics. Mobile laboratory

QH0052

The set consists of components for conducting mechanics experiments and for studying the movement, mutual interactions of bodies and the state of equilibrium between them. By combining individual elements, it is possible to create experiments which help to understand physics-related topics. With this set you can demonstrate:

- the law of the lever
- Newton's Third Law
- the phenomena of stick-slip and friction
- the construction and working of dynamometer
- the relation between mass and density

- the set includes: a plastic tray, a ballistic gun, a motion retention device, a lab tray, a steel ball, a lab stand, a lab level, weights - 6 pcs, 100g each; a tribometer; a dynamometer; a ruler, a pendulum - 3 pcs;
- a set of blocks of different weights (3 pcs);
- age: 8+



Lever with stand

QH0032

A demonstration set for the uniformly accelerated motion.

- size: 49 x 8,5 x 25 cm



Uniform motion and uniformly accelerated motion.

Demonstration set

QH0053

A device for exploring the properties of the uniform motion and the uniformly accelerated motion during science lessons.

- size: 110 x 20 x 24 cm;
- lb.battery-powered (battery not included)

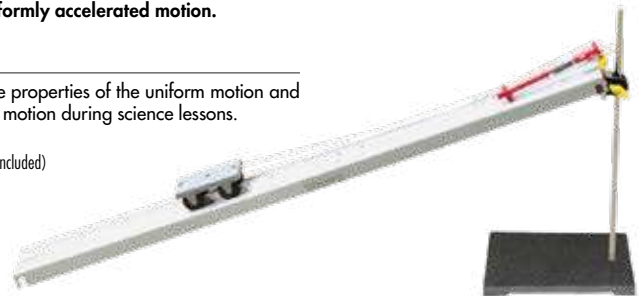



Gyroscope - demonstration model HG0094

The gyroscope model demonstrates the conservation of the orientation of its axis of rotation when no moments of external forces are present. It also shows the gyroscope's reaction to a nonzero moment of an external force. The device is made of a metal circle placed on a steel axis with horizontal

holes for threading a string used to set the circle rotating by pulling. The axis has two adjustable tapered roller bearings. In the set there are also two stands with support arms. One allows the gyroscope to rotate around the vertical axis, the other allows a tilt. Also, the string with a T-handle is included.

- 4 elements: gyroscope 10,7 x 10 x 17 cm, D 10 cm, weight 175 g; 2 stands, string 60 cm with a handle;
- materials: metal, plastic



Centrifugal force kit HG0093

A centrifuge can be used in physical experiments. Combined with other sets, it may come useful in experiments in acoustics or thermodynamics. The rotational velocity of the spindle depends on the velocity of the manually-powered pulley wheel. The machine can be used both vertically and horizontally. The kit helps explain

the processes taking place in a washing machine while spinning wet clothes (spin dryer), simulate a lab centrifuge (centrifugal separator), demonstrate directly how centrifugal force works (Watt regulator with a shutter valve in cross section).

- 5 elements: centrifugal apparatus, 2 test tubes with caps, Watt regulator with a shutter valve model, centrifuge;
- dim.: 23,5 x 11,5 x 47,5 cm

OSCILLATING MOTION



Ripple tank HG0126

A device for demonstration of various waves on water surface. Intended for projecting images on a wall (projector) or the ceiling (stroboscope).

- size: 35 x 28 x 6,4 cm;
- tank size: 28 x 27 x 3,5 cm;
- power supply DC 6V-9V



Barton's pendulum HG0147

An aid to demonstrate the mechanical resonance of vibrations. The resonance pendulum consists of 7 balls hanging from the same base.

- size: 45,6 x 33 x 10 cm, weight 1,5 kg



Mathematical pendulum HG0146

The model demonstrates the oscillation of an object of point form after setting it swinging and determining the deflection angle, amplitude of swings and period.

- H 122 cm, weight 5,4 kg

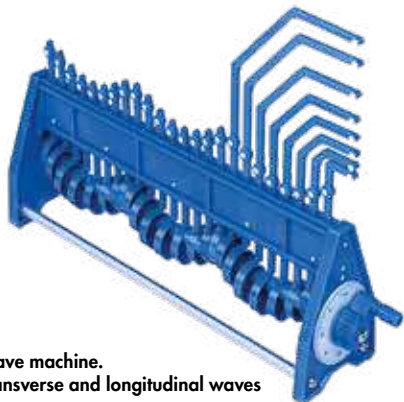

Wave machine.
Transverse and longitudinal waves
HG0097

An aid to demonstrate the phenomenon of transverse and longitudinal waves. Very useful in observation and exploration of such issues connected with a wave as its length, frequency, amplitude, reflection and period. The machine consists of a shaft with a crank at its end. Rotation of the shaft sets the vertical rods with white spots in motion. Additionally, 8 rods bent at the same given angle to help observe how both types of waves are formed.

- size: 50 x 12 x 30 cm; weight 0.85 kg; material: plastic



Tuning fork 440 Hz
QH2206

- set: 1 hammer + 1 tuning

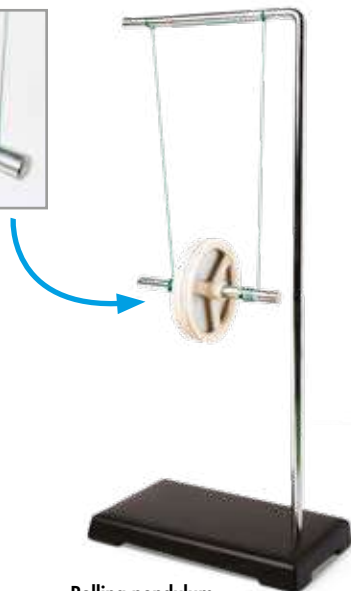

Rolling pendulum
QH0040

- size: 23 x 10 x 41 cm

Assorted spring set
TS19305

- tension springs:
 10 pcs-7 x 13 cm, 10 pcs-6 x 12 cm,
 10 pcs-5.5 x 27 cm, 10 pcs-9.5 x 16 cm,
 12 pcs-9 x 18 cm, 8 pcs-9 x 35 cm,
 10 pcs-5.5 x 38 cm, 10 pcs-10 x 19 cm
- compression springs:
 10 pcs-5 x 10 cm, 10 pcs-5.5 x 14 cm,
 10 pcs-6 x 10 cm, 8 pcs-8 x 13 cm,
 10 pcs-7.5 x 17 cm, 12 pcs-8.5 x 26 cm,
 12 pcs-8 x 50 cm, 12 pcs-7 x 55 cm,
 12 pcs-4 x 70 cm, 8 pcs-5 x 34 cm,
 10 pcs-7 x 25 cm, 10 pcs-8 x 23 cm

Screw spring set
TS15714

A set of 5 springs of different moduli of elasticity.

- 0.5N,1N,2N,3N,5N

TERMODYNAMICS



Hot-Air Rework Station NA0079

2-in-1 Hot Air Rework Station with an LED display. This compact in size rework station combines a hot air gun with a soldering iron which makes it perfect for maintenance and production works. The device is equipped with a precise temperature control, a PID regulator controlled by a microprocessor as well as closed-loop sensors. The high-power hot air gun has a high air flow, and it heats up rapidly. Thanks to these features, it can be used for lead-free soldering. The low-voltage heating element of the soldering station is ideal for working with sensitive components. Additionally, the 2-in-1 Hot Air Rework Station has an automatic alarm function and an effective fault detection system.

- rated voltage: ac: 220v +/- 10% 50hz,
- output power: 750w +/- 10% (max.),
- working environment: 0-40°C,
- relative humidity <80%,
- storing temperature: -20-80°C;
- hot air gun:
- rated voltage: ac: 220v +/- 10% 50hz,
- output power: 700w +/- 10%,
- temperature range: 100 ~ 480°C,
- gas flow rate: 120l/min (max.),
- temp. stability: +/- 2°C (static).
- soldering iron:
- rated voltage: ac: 26v +/- 10% 50hz,
- output power: 40w +/- 10%,
- temperature range: 200 ~ 480°C,
- temp. stability: +/- 2°C (static),
- tip to ground resistance: <2 ohm,
- tip to ground potential: <2mv.

A device that demonstrates the linear (thermal) expansion of metals HG0021

This set helps to perform a qualitative comparison of the degree of thermal linear expansion of the three materials: steel, aluminum and brass in the form of rods. This live experiment, thanks to the indicators acting as single-sided levers with large leverage, allows the user to clearly assess the relative thermal expansion of these metals.

Structure/Technical description

- the set consists of a metal base (approx. 23 x 9 x 7 cm) with two brackets, three indicators in different colours (length: 19 cm) and plate holders, scale on brackets, three rods for experiments (steel, aluminium, brass, length: 18 cm, dia. 6 mm), convection limiter and a plate for alcohol (diameter 7 cm and height 1 cm)

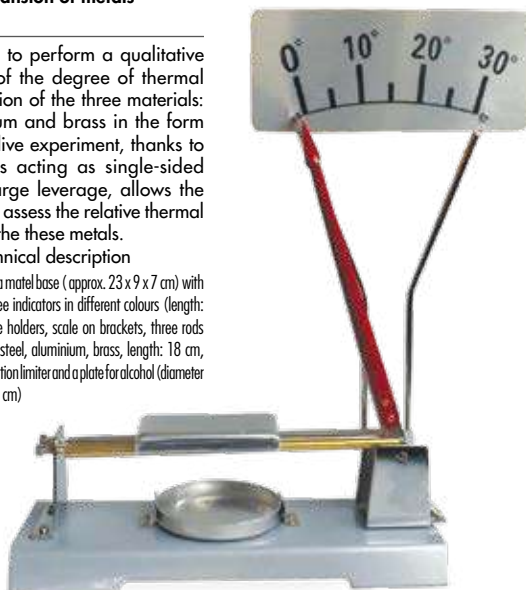

Instrument for demonstrating the thermal conductivity (expansion) of different metals HG1015

Device with 5 metal rods (arranged in the shape of a star) which allows the students to compare thermal conductivity of aluminium, brass, steel, zinc and copper by melting wax balls at the ends of the rods. Each rod has a notch to hold the wax.

- length: approx. 340 mm

Thermal expansion. Demonstration set QH0038

A demonstration set for thermal expansion of solids.

- made of metal



AEROSTATICS



Boyle's law demonstration model
HG0096

The device demonstrates Boyle's law i.e. it shows a relationship between the pressure and volume of air at a constant temperature. The user can experiment with the elasticity of a measured amount of gas. Turning the handle compresses the air. The volume, temperature and pressure can be read from the display screen on the scales.

- box dim 24 x 19 x 15 cm



Magdeburg hemispheres
QH2115

2 hemispheres, with handles attached, for demonstrating the operation of



Pascal's pressure sphere demonstration model
HG0099

A device to present Pascal's law in action. It is made of a steel sphere connected to a tubular manual pump. The sphere is pierced with small holes. After filling it with water and pushing the piston the water squirts out in even jets.

- L 35 - 53 cm, sphere D 8 cm, sphere V 0,2 l;
- 9-10 holes

atmospheric pressure when the two elements are pressed together so that the rims fit together and the air is next sucked out.

- D 12 cm; made of plastic and rubber

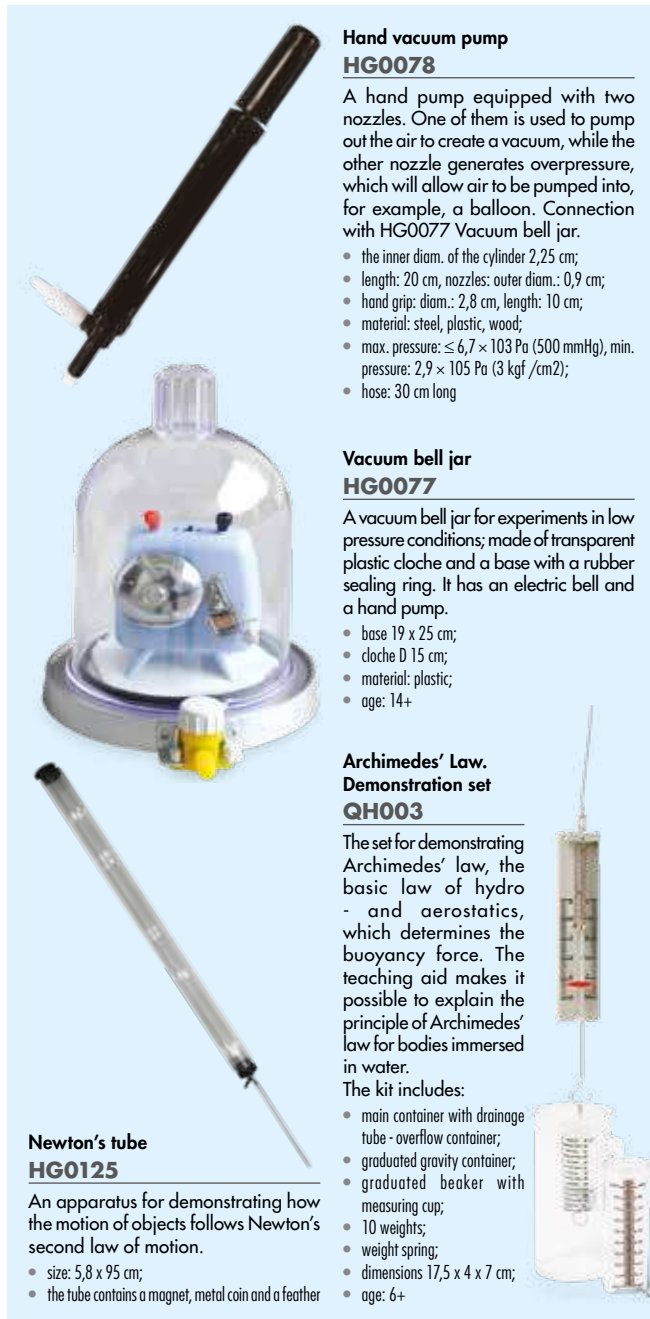

Hand vacuum pump
HG0078

A hand pump equipped with two nozzles. One of them is used to pump out the air to create a vacuum, while the other nozzle generates overpressure, which will allow air to be pumped into, for example, a balloon. Connection with HG0077 Vacuum bell jar.

- the inner diam. of the cylinder 2,25 cm;
- length: 20 cm, nozzles: outer diam.: 0,9 cm;
- hand grip: diam.: 2,8 cm, length: 10 cm;
- material: steel, plastic, wood;
- max. pressure: $\leq 6,7 \times 10^3$ Pa (500 mmHg), min. pressure: $2,9 \times 10^5$ Pa (3 kgf./cm²);
- hose: 30 cm long

Vacuum bell jar
HG0077

A vacuum bell jar for experiments in low pressure conditions; made of transparent plastic cloche and a base with a rubber sealing ring. It has an electric bell and a hand pump.

- base 19 x 25 cm;
- cloche D 15 cm;
- material: plastic;
- age: 14+

Archimedes' Law. Demonstration set
QH003

The set for demonstrating Archimedes' law, the basic law of hydro- and aerostatics, which determines the buoyancy force. The teaching aid makes it possible to explain the principle of Archimedes' law for bodies immersed in water.

The kit includes:

- main container with drainage tube - overflow container;
- graduated gravity container;
- graduated beaker with measuring cup;
- 10 weights;
- weight spring;
- dimensions 17,5 x 4 x 7 cm;
- age: 6+

Newton's tube
HG0125

An apparatus for demonstrating how the motion of objects follows Newton's second law of motion.

- size: 5,8 x 95 cm;
- the tube contains a magnet, metal coin and a feather

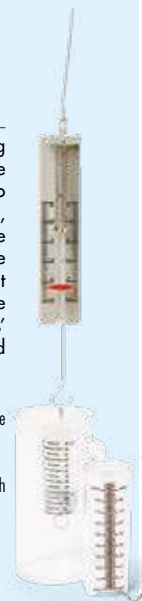

ELECTRICITY



**Multimeter
TS15090**

- voltmeter and ammeter;
- separate 10 A socket;
- battery-powered (battery not included)



**Lab power supply
HG3005**

A very accurate power supply with protection against high temperature, short circuit, overload and damage. The output voltage and current are controlled steplessly with coarse and fine knobs - separately for the output current and voltage. The device operates in „constant current“ (CC)

and „constant voltage“ (CV) modes. General specifications:

- output voltage 0÷30 V, output current 0÷5 A;
- voltage and current stabilization;
- ripple noise 0,5 mV rms;
- simultaneous reading of amperage and voltage for each output;
- digital display (2 x LCD - 220V);
- fan;
- LED indicator



**Water electrolysis
experiment device
HG0130**

An electrolyzer in the form of a cylindrical plexiglass container with a raised bottom with two banana sockets (+ and -) underneath. These are connected with electrodes threaded through rubber stoppers of respective colours placed in the inlets of two acrylic test tubes with scales marked.

- size: 12 x 8,5 cm



**Galvanometer
HG0070**

This sensitive galvanometer is an educational tool which can be helpful in physical laboratories. An analogue meter is used to measure very low values of electric current. It is equipped with three sockets with clamps adapted to cables with forks or banana plugs.

- 13,3 x 9,7 x 10,2 cm; weight: 165 g;
- measuring range: -300µA-0-300µA;
- supply voltage: alternating current 220 V, 240 V;
- direct current: 24 V; accuracy class: 0,5;
- working temperature: 10 ~ + 55 oC



**Pointer electroscope
QH0028**

- the needle indicates changes in electric current
- 1 pc; size: 20,5 x 15 x 37 cm



**Voltmeter DC 0~1~5 V
RV1007**

- measurement range: 0-5 V, accuracy ± 2,5% FS, sensitivity: 1 mA, dim: 133 x 97 x 100 mm, weight 0,3 kg, scales: 0-5 V; 0-3-15 V; 0-5-15 V; -1-0-3 V; -5-0-15 V



**Ammeter AC 0-1 A
RV1002**

- measurement range: 0-1 A, accuracy ± 2,5% FS, ripple voltage: 30 mV, dim: 133 x 97 x 100 mm, weight 0,4 kg, scales: 0-1A, 0-5A, 0-0.6A-3A

**Voltmeter AC 0~3 V; 0~5 V, 0~15 V
RV1008**

- measurement range: 0-3 V; 0-5 V, 0-15 V, accuracy ± 2,5% FS, dim: 133 x 97 x 100 mm, weight 0,3 kg, scales: 0-5 V; 0-3V-15 V; 0-5V-15 V

**Ammeter DC -0,2~0~0,6 A; -1~0~3 A
RV1001**

- measurement range: -0,2-0-0,6 A; -1-0-3 A, accuracy ± 2,5% FS, ripple voltage: 75 mV, dim: 133 x 97 x 100 mm, weight 0,3 kg, scales: 0-1A, 0-5A



Foil electroscopes
AM0113Z

- size: 21 x 9 x 24 cm

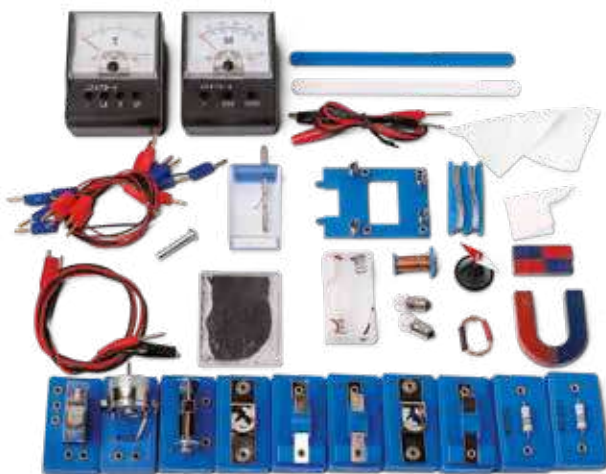

Experiments with electricity

QH0033

The set consists of devices and components which allow students to discover the world of electricity and magnetism.

- The kit includes: An ammeter (0 – 500 – 100) mA, a voltage meter (0 – 1,5 – 3) V, a switch – 3pcs; a bulb holder – 2 pcs; a resistor (5W), a resistor (2W); an electromagnetic relay (3V); a slide potentiometer; an electric device (3V); a seton's stand; a winding plate; a small magnetic needle; a bar magnet – 2 pcs; a u-shaped magnet; iron filings; an electroscope; fur, silk; a transparent cane; a blue cane; an iron core; a small loop; a resistance wire; a resistance wire; a lightbulb (0,3A; 2,5 V) – 2 pcs; a set of wires – 10 pcs; a battery box; a circuit board. The set is sent in a box; dim.: 24,5 x 4,5 x 14,5 cm; age: 8+



Electric motor.
Demonstration model
HG0071

This model is a perfect visual aid for demonstrating how the DC electric motors work. This device is made of steel and it is mounted on a stable base. It works freely and quietly. Equipped with two banana sockets for connecting a 2 to 4 V power source.

- size.: 8,8 x 8,5 x 10,4 cm;
- material: plastic, metal



Electric motor.
Demonstration model
QH0035

- size: 9 x 6 x 27 cm

100 Ohm resistor
HG0150

The resistor is a simple device allowing to regulate the current and voltage. It has a solid metal case. The contact elements with the slider are made of copper-plated graphite. This device ensures good linearity. The scaled graduation from 0 to 100 provides precision.

- 28,5 x 14 x 9,5 cm; dia. of the ceramic cylinder: 4,7 cm; weight: 1,2 kg; max voltage: 380VAC, 400VDC; resistor tolerance: + 10%; insulation resistance: >3x10⁹ Ω; grounding resistance: < 0,1 Ω; power: 160VA; amperage: 1,25 A; electrical resistance: 100?

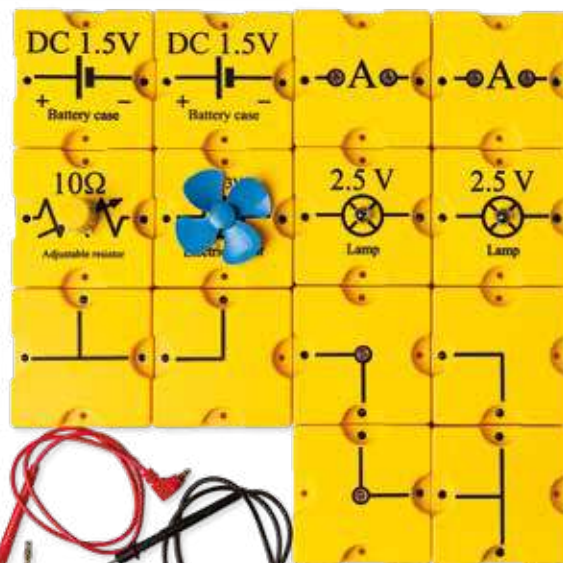

Block Circuit Board
HG0005

A demonstration set of electric circuits.

- size: 36 x 36 x 5,5 cm

Van de Graaff generator HG0008

- set includes: a conical and a spherical conductor with a spike and a stand, a spherical conductor with an insulated handle, an electrostatic mill, a brush
- manual drive
- size: H 74 cm, dome ø 26,5 cm



Induction coils QH2410

An aid to explore electromagnetic induction and explain how a transformer works. The primary coils is made of enamelled copper wire of large diameter and very low resistance (ca 0,5 ohm). The secondary coil is wound with fine enamelled wire with resistance 100 ohm. Each coil has two 4 mm sockets.

- size: 21 x 15 x 23 cm

Electromagnet QH2411

The electromagnet consists of a coil of wire wrapped around a ferromagnetic core in an open magnetic circuit. On the outer layer there are a few rubber coils to indicate the winding direction. The terminals allow external devices to be connected in series or in parallel. The electromagnet can present the relationship between magnetism and electricity. It induces a magnetic field when electric current is passed through it.

- size: 15 x 12 x 3,5 cm



Lenz's Law HG0095

The model consists of two metal loops fixed to the opposite ends of an aluminium bar which can move freely on a pin. One loop is complete, the other one split. When the magnetic flux changes, according to Lenz's law current is induced in the complete loop to oppose the change.

- size: 20,3 x 15,2 x 7,6 cm

ELECTROSTATICS

Wimshurst machine BZ8002

- creates lightning 6 cm long;
- dim of the base: 29 x 18 cm, H 34 cm



Electrostatic pendulum QH0029

- 2 pcs;
- H 30 cm

MAGNETICITY



Magnetic field lines
QH0030

A demonstration mini-set.

- size: 18 x 18 x 21 cm



Magnetic field lines
QH2030

- size: 17,5 x 17,5 x 20,5 cm;
- the kit includes a bar magnet



U-shape Magnet
QH0034

- made of chrome steel

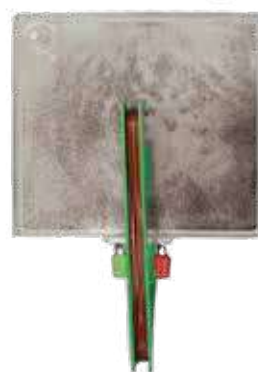
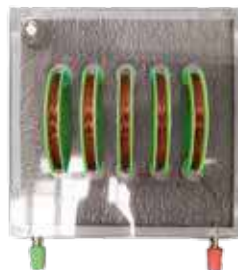

Magnetic field around a wire. Demonstration set
QH0119

The set consists of three devices for the presentation of magnetic field lines around an electrified wire (rectilinear, circular, coil);

- 3 pcs;
- size: 107 x 97 x 10 mm



Magnetic attractions kit
EI0052

An assortment of magnets and magnetic objects for exploring magnetism in-depth.

- 18 elements;
- age: 8+



Small magnetic needles
QH0050

The set contains 10 miniature compass needles on stands.

- 10 pcs;
- stainless steel;
- size: 3 x 2,5 x 3,7 cm

OPTICS

Equilateral prism glass AM0972

Prisms are essential tools for teaching about light refraction and dispersion and come in a variety of shapes and sizes.

- size: 2,5 x 10 cm



Set of 6 lenses 38 mm AM0914

- 6 lenses D 38 mm
- double-convex, double-concave, flat-convex, flat-concave, concave-convex, convex-concave
- material: glass

Set of 6 lenses 50 mm AM0913

- 6 lenses D 50 mm
- double-convex, double-concave, flat-convex, flat-concave, concave-convex, convex-concave
- material: glass



Set of prisms QH2079

A set of acrylic prisms and lenses with magnets encased for easy fastening on a magnetic board. The elements can be used to explore the nature of light (refraction, dispersion, internal reflection). The plastic dial with degree markings can be used together with other elements to experiment more with optics.

The set contains 8 optical accessories:

- flat-convex lens 4 x 8 x 1 cm;
- right-angled triangular prism 6 x 6 x 1 cm;
- double-convex lens 4.5 x 13 x 1 cm;
- double-concave lens 5 x 13 x 1 cm;
- convex-concave lens 4.5 x 13 x 1 cm;
- flat-concave lens 1 x 6.5 x 1 cm;
- convex-flat lens 1 x 6.5 x 1 cm;
- rectangular prism 2 x 13 x 1 cm
- 13 cm plastic dial with degree markings



Wooden lens holder HG0091

A universal holder for supporting lenses during presentations and experiments in optics. Made of wood, it has a height-adjustable arm with a wing bolt lock. The V-shaped slot will hold lenses from 38 to 50 mm in diameter.

- size: 9,7 x 4,5 x 15 cm



Convex lens and concave lens QH0056

Spherical and convex spherical mirror on separate bases.

- dia. 10 cm;
- 2 pcs



Optical bench with equipment QH0019

- set contains: a torch with bulb, 5 handles, 3 graphs, a screen with a handle, 4 convex lenses, 2 concave lenses;
- size: 101 x 6,5 x 20 cm



Waterproof flashlight with a zoom CD7217

High quality flashlight with Nowa Szkoła logo equipped with T6 LED diode emitting light with a power of up to 8000 lumens. The flashlight's body is made of aviation aluminium, which is lightweight and resistant to damage. O-ring system and component compatibility protect against heavy rain, moisture. It's non-slip surface and practical wrist strap allow it to be used outdoors. The flashlight also has a ZOOM function. Regulated focus of the beam enables to illuminate closer and further objects. This device is powered by a high-quality lithium-ion battery. The set includes a container which, if necessary, allows the battery to be replaced with batteries.

- length: 13,6 - 15,8 cm;
- dim. 3,6 cm;
- extendable zoom: x1, x250, x500, x1000, x2000;
- wrist strap;
- battery 18650, battery compartment 3 x AAA, fluorescent switch;
- material: aviation aluminium



Color mixing apparatus QH0055

A special projector using 3 strong low-voltage LED lamps (red, green and blue) in special holders and sockets to ensure adjustment of the angle of incidence for each colour ray onto the white screen.

- size: 22 x 17 x 16 cm;
- wall fasteners and manual included



Laser refraction tank HG0089

The model illustrates how a beam of light gets reflected when passing through a different medium (water in an acrylic tank) and how it gets reflected. The transparent tank with water has a scale on its back wall (360°) and a movable arm with a laser activated with a switch

- size: disk D 16 cm, H 25 cm; the laser requires a battery



Geometrical optics. Demonstration set QH0049

An instrument for optic experiments, e.g. refraction and reflection of light or near- and far-sightedness

- size: 75 x 24 x 37 cm

LASER POINTER

- length: 15 cm; beam's type: straight line;
- laser power: 5 mW;
- power supply: 2 x AAA (not included);
- material: copper, aluminium; security label



- green CD7230

- colour of the beam: green;
- laser range: 500 m;

- red CD7231

- colour of the beam: red;
- laser range: 500-1000



Diffraction grating set HG1027

A set of optical devices to demonstrate the diffraction and interference of light and to obtain its spectrum. The analysis of the location of light and dark diffraction stripes makes it possible to determine the length of the wave falling onto the grating. All the diffraction gratings are made of a plastic frame (5 x 5 cm) and foil (35 x 23 cm) with openings of different shapes and spacing. They can be mounted on special stands or optical benches. The set consists of 5 gratings:

- with 3 single slits (width 0,05; 0,1; 0,2 mm)
- with 3 double slits of 0,05 mm (spacings 0,2; 0,3; 0,45 mm)
- with single slits, 2 slits, 3 slits, 4 slits, multiple lines (30 and 60 lines/mm, circular apertures (D 0,36 mm), triangular apertures (side 0,3 mm), square apertures (side 0,2 mm), rectangular apertures (0,6 x 0,28 mm), all slits 0,06 mm wide with spacing 0,05 mm
- with 3 rectangular apertures, each formed by lines intersecting at right angles, number of lines: 20, 40 and 60 respectively
- with round apertures of diameters 0,2; 0,3; 0,4 mm

SAFETY



Safety Glasses
QH0058

- for adult



Safety glasses
VO8603

Safety glasses with an elastic headband.

- one size (to fit a child's head);
- offer valid while stock lasts

LABORATORY COAT

- fabric: 50% cotton, 50% polyester fibre;
- washing temperature 40 degrees;
- 3 pockets, hanger loop, Nowa Szkoła logo embroidered on the upper pocket



Size S

NS2653

- dimensions:
length: 107 cm,
sleeve: 57 cm,
chest: 106 cm,
hip: 110 cm

Size M

NS2654

- dimensions:
length: 109 cm,
sleeve: 59 cm,
chest: 110 cm,
hip: 116 cm,

Size L

NS2655

- dimensions:
length: 111 cm,
sleeve: 60 cm,
chest: 112 cm,
hip: 118 cm,

Size XL

NS2656

- dimensions:
length: 115 cm
sleeve: 64 cm
chest: 114 cm
hip: 120 cm



ICT

INTERACTIVE MONITORS

In this category we offer products with modern-day telecommunication and IT solutions, including web-based software: displays, OPS computers, 3D printers, microcontrollers, robots, and programming kits perfect for beginners.

86" Interactive monitor with built-in camera and accessories NS9286

Display / Resolution:	4k 3840x2160
Panel / Diagonal:	D-LED /86"
Model:	86DL-AL
Contrast:	5000:1
Brightness:	350 cd/m2-20
Image aspect ratio:	16:9
Panel response time:	8 ms
Color depth:	10 Bit 16:7M
Screen size:	1895mm x 1065.9mm
Screen:	frosted glass 4 mm and a hardness of 7 on the Mohs scale
Viewing angle:	178°
Panel lifetime:	50 000 h
Touch technology:	infrared(IR)
Response time:	5 ms
Number of touch points	20
Precision:	<1 mm
Writing Mode:	opaque objects
Cursor Speed:	200 dot/s
Operating system:	Operating system: Android 8.0 Windows 10 after adding OPS
Ports:	
HDMI input ports: 3XHDMI, HDMI output port: 1xHDMI, DisplayPort input ports: 1xVGA, 3XHDMI, 1XAV (MINI 3in1), 1XYPbPr (3in1), VGA input port: 1x AVG, 1x MIC, AV input: 1XAV (MINI 3in1), AV Output: 1 x AV Out, USB Ports (Rear): 2XUSB2.0 USB Ports (Front): 2XUSB2.0 + 1XUSB3.0, Touch Interface USB Ports: 2XUSB TYP-B TO EXTERNAL PC / HDMI TOUCH OUTPUT, Serial ports: 1XRS232, LAN ports (RJ45): 1XRJ45, Built-in speakers: 2 x 15W, Headphone output: 1 x 3.5mm Jack, Digital output: 1xDigital Coaxial, OPS slot: 1XOPS SLOT, Card reader: 1XSD CARD READER, PLUG & PLAY: YES	
Built-in Camera:	YES/8 Mpix
Wi-Fi:	IEEE802.11a/b/g/n Dual Band 2.4GHz/5GHz lub IEEE802.11an 2.4GHz
Weight:	72 kg
dim:	1950.8mm x 1145.5mm x 91.8mm
Wall mounts:	YES
Power supply:	AC 220-240 V 50/60 Hz
Power:	370W
Certificates:	CE, ROHS, ISO 9001, ISO 14001



75" with built-in camera and accessories

NS9275

Display/resolution:	4k 3840x2160
Panel/diagonal:	D-LED /75"
Model:	65DL-AL
Frame:	black metal
Contrast:	5000:1
Brightness:	350cd/m2-20
Aspect ratio:	16:9
Response time:	8 ms
Colour depth:	10 Bit; 16:7M
Screen size [mm]:	1650 x 929
Screen:	4 mm frosted glass, a hardness of 7 on the Mohs scale
Viewing angles:	178°
Lifespan:	50 000 h
Touchscreen technology:	infrared radiation [IR]
Response time:	5 ms
Touch points:	20
Writing mode:	200 dot/s
Operating system:	Android 8.0; Windows 10 after the installation of OPS
Ports:	
Input HDMI port: 3XHDMI, Output HDMI port: 1xHDMI, Input ports DisplayPort: 1xVGA, 3XHDMI, 1XAV[MINI 3in1], 1XYPbPr[3in1], VGA input port: 1x AVG, 1x MIC, AV input: 1XAV[MINI 3in1], AV output: 1 x AV Out, USB ports [back]: 2XUSB2.0, USB ports [front]: 2XUSB2.0+1XUSB3.0, USB port of the touch interface: 2XUSB TYPE-B FOR EXTERNAL PC/HDMI OUTPUT, serial ports: 1XRS232, LAN ports [RJ45]: 1XRJ45, Built-in speakers: 2 x 15W, Headphone output: 1 x 3.5 mm minijack, Digital output: 1xDigital Coaxial, OPS: 1XOPS SLOT, Cart reader: 1XSD CARD READER, PLUG & PLAY: YES	
Built-in camera:	YES/8 Mpix
Wi-Fi:	IEEE802.11a/b/g/n Dual Band 2.4GHz/5GHz or IEEE802.11an 2.4GHz
Weight:	60 kg
dim	1731 x 1037 x 111 mm
Power supply:	AC 220-240 V 50/60 Hz
Power supply unit:	240W
Certification:	CE, ROHS, ISO 9001, ISO 14001



OPS with Intel Core i5, Windows 10 Home

NS9215

- CPU: Intel® Core™ 5 generation i5-7400 3.00 GHz (3.50 GHz in Turbo mode) processor; Intel® H110 RAM: 4GB DDR4-2400 SO-DIMM, 1x hard drive 128 GB SSD M.2, 1 x SATA connector: HDMI x1; VGA x1; DP x1; USB 3.0 x6; Ethernet (10/100/1000 MB) / Wi-Fi 802.11ac (2.4 GHz / 5 GHz) with 2 external antennas; RJ45 x1; headphones output 3,5 mm; microphone input 3,5 mm; Bluetooth 4.0



INTERACTIVE MONITORS



65" with built-in camera and accessories

NS9265

Display/resolution:	4k 3840x2160
Panel/diagonal:	D-LED /65"
Model:	65DL-AL
Frame:	black metal
Contrast:	5000:1
Brightness:	350cd/m2-20
Aspect ratio:	16:9
Reaction time:	8 ms
Colour depth:	10 Bit; 16.7M
Screen size [mm]:	1428 x 804
Screen:	4 mm frosted glass, a hardness of 7 on the Mohs scale
Viewing angles:	178°
Lifespan:	50 000 h
Touchscreen technology:	infrared radiation (IR)
Reaction time:	5 ms
Touch points:	20
Writing Mode:	opaque objects
Cursor Speed:	200 dot/s
Operating system:	Operating system: Android 8.0 Windows 10 after adding OPS
Ports:	
Input HDMI port: 3XHDMI, Output HDMI port: 1xHDMI, Input DisplayPort: 1xVGA, 3XHDMI, 1XAV(MINI 3in1), 1XPbPrf(3in1), VGA input port: 1x AVG, 1x MIC, AV input: 1XAV(MINI 3in1), AV output: 1 x AV Out, USB ports (back): 2XUSB2.0, USB ports (front): 2XUSB2.0+1XUSB3.0, USB port of the touch interface: 2XUSB TYPE-B FOR EXTERNAL PC/HDMI OUTPUT, serial ports: 1XRS232, LAN ports (RJ45): 1XRJ45, Built-in speakers: 2 x 15W, Headphone output: 1 x 3.5 mm minijack, Digital output: 1xDigital Coaxial, OPS: 1XOPS SLOT, Card reader: 1XSD CARD READER, PLUG & PLAY: YES	
Built-in camera:	YES/8 Mpix
Wi-Fi:	IEEE802.11a/b/g/n Dual Band 2.4GHz/5GHz or IEEE802.11an 2.4GHz
Weight:	47 kg
dim:	1731 x 1037 x 111 mm
Power supply:	AC 220-240 V 50/60 Hz
Power supply unit:	320W
Certification:	CE, ROHS, ISO 9001, ISO 14001



DIGITAL





Mobile stand for interactive monitors **NS9216**

Mobile stand on two sturdy legs for interactive monitors: NS9265, NS9275 and NS9286. It can support a monitor over 65", 75" and 86" weighting up to 150 kg. The stand is equipped with a practical shelf placed under the monitor, dim.: 73 x 34 cm, and locking castors. Frame: powder coating.

- height: 1,8 cm, width at the base: 105,5 cm;
- width at the base: 47 cm;
- height while the monitor is mounted: 2,2 cm



3D PRINTER CABINET

3D print is slowly becoming a standard in schools. Thanks to this new technology of three-dimensional print, the process of learning is much more interesting and much easier to understand. To fully take advantage of the possibilities which 3D print provides, good quality accessories and a 3D printer are necessary. Among the selected products, you can find high quality filaments and a specially designed printer stand with a cabinet.



Cabinet for 3D printers and filaments

BAL0002

- cabinet made of birch and grey chipboard with three hooks for filaments;
- pair of lockable doors;
- lockable cabinet inside has a shelf;
- the furniture has five legs for strength and stability of the structure;
- the set includes three plastic containers with lids in a color mix;
- dim: 92 x 53 x 1,3 cm, top height: 1,1 cm

Cabinet for 3D printers and filaments

BAL0001

- printer stand with a cabinet for the printer and filaments;
- it is made of furniture board, 18 mm thick, in birch colour and MDF board, 12 mm thick, in grey colour;
- the stand is equipped with 6 deep plastic containers, 3 white and 3 grey, as well as a pair of doors with a lock;
- inside the stand, there are two shelves;
- 3 filament holders and 2 side limiters for the printer are placed on the back wall;
- beige plastic legs, 5 pcs, can be replaced with furniture castors, sold separately – NJ0904;
- dim of the stand: 103,7 x 57 x 181,8 cm;
- tabletop height: 1,4 cm



3D PRINTER

COMPLETELY CLOSED HOUSING

MAGNETIC PLATFORM
FOR QUICK DISASSEMBLY

SMART DOOR

QUIET PRINTING

REMOTE PRINTING AND MONITORING

Printer 3D NS Digital Creality
Sermoon V1 Pro
NS9220



- printing technology: FDM;
- printing temperature: 180-250;
- diam.: of the nozzle: 0,4 mm;
- height of the layer: 0,1–0,4 mm;
- working area: 17,5 x 17,5 x 16,5 cm;
- print preview: yes;
- display: touch screen, 4,3 inches;
- diam. of the filament: 1,75 mm;
- filament types: PLA, ABS, PET;
- connection: Wi-Fi, file types: STL, OBJ, AMF, compatible slicer;
- weight: 11,5 kg;
- dim. of the printer: 40 x 38 x 43 cm;
- supported operating systems: Windows XP/7/8/10 (32 bit/64 bit), Mac OS, Android;
- printing software: Simplify3D, Cura, Creality Slicing Software, RepetierHost;
- camera: yes, Full HD 1080 p;
- 3D printing library of files and a library of printing files created by the user;
- menu in English;
- software in Polish;
- 24 months warranty;
- 1 filament is included with the printer;
- the colour is chosen randomly





Filament dryer for Creality 3D NS9220D

Filament dryer (dim.: 233 x 266 x 99 mm). When the filament is not used for long periods of time, it may become damp. Thanks to the dryer, it will be possible to maintain perfect storing conditions for the filament and keep it ready to use all the time. The box is dustproof and compatible with various filament spools (up to 1 kg) This dry box is controlled by a knob and the working time can be set to 2,4 or 8 hours. It is shown on digital display. Specification:

- power supply: 100 V up to 240 V AC;
- power: 120 W;
- material: plastic;
- temperature range: 50°C (+/- 10°C)

3D PRINTER REPLACEMENT PARTS



Adhesive magnetic bed for Creality Sermoon V1 Pro NS9220C

Pad is covered with microporous coating which provides strong adhesion of 3D prints. Interchangeable magnetic pad for NS Digital - Creality Sermoon V1 Pro 3d printer. The pad is easy to clean, after cooling down, slightly bend the pad to safely remove any prints.

- square printer pad; dim.: 185x 185 mm



Replacement nozzle for Creality Sermoon V1 Pro NS9220B

Interchangeable copper nozzle, with the diameter of 0,4 mm diameter, dedicated for 1.75 mm filament.

3D PEN



3D Pen NS9217

3D pen is used for manual 3D prints. Prints made by this device appear almost immediately in front of our eyes. The pen can be connected to a power bank via USB cable. Filaments with a diameter of 1,75 mm are compatible with this pen.

- included in the set are: three metres of filament;
- pad and power supply



3D pen filament NS9218

Set of filaments with overall length of 100 meters. Mix of 20 colours – 5 meters of filament per each colour.

- filament's diameter: 1,75 mm



3D PRINTING FILAMENTS

3D printer filament PLA 1 kg

- weight: 1 kg (on spool);
- filament's diameter: 1,75 mm



transparent		NS9221
white		NS9222
yellow		NS9223
blue		NS9224
red		NS9225
grey		NS9226
green		NS9227
black		NS9228
pink		NS9229
orange		NS9230
violet		NS9231
light blue		NS9233
beige		NS9234
fluorescent green		NS9232
fluorescent yellow		NS9235

MICRO-CONTROLLERS

Microcontrollers are products that will successfully introduce both students and seniors to the world of programming. They activate both manually and mentally. By combining the practical ability to work on electronic components and using the Arduino programming platform, learning becomes faster and easier.



Microcontroller with sensors and accessories. Set of 37 sensors and modules - Arduino Sensor Kit

VR0002

Set includes:

- 1x high quality box
- 1x modules introduction
- 1x tutorial on CD, 1x joystick module for PS2 games
- 1x IR receiver module
- 1x laser sensor module
- 1x DHT11 temperature and humidity sensor, 1x IR emitter sensor module, relay module (1 channel)
- 1x infrared obstacle avoidance sensor module
- 1x touch sensor
- 1x sound sensor, 1x DIP 3 Colour LED Module
- 1x flame sensor module
- 1x 3 Colour SMD LED Module
- 1x Linear magnetic Hall sensor
- 1x blue rotary encoder module
- 1x digital temperature sensor
- 1x active buzzer
- 1x passive buzzer
- 1 x photo interrupter module
- 1x DST18B20 temperature sensor module
- 1x 5mm bi-colour LED module
- 1x tilt switch
- 1x 7 coloured flash LED module
- 1x photoresistor module
- 1x vibration switch module
- 1x knock sensor module, 1x TCRT5000 tracking module
- 1x tactile switch module
- 1x HCSR04 ultrasonic sensor (4 pins)
- 1x GY-521 MPU6050 module (with soldering)
- 1x HCSR501 PIR motion detector (green)
- 1x LCD1602 display (with soldering)
- 1x DS3231 AT24C32 IIC module (battery not included)
- 1x MB102 3.3V 5V motherboard power supply module
- 1x 4x4 membrane switch
- 1x matrix keyboard
- 1x water level sensor.



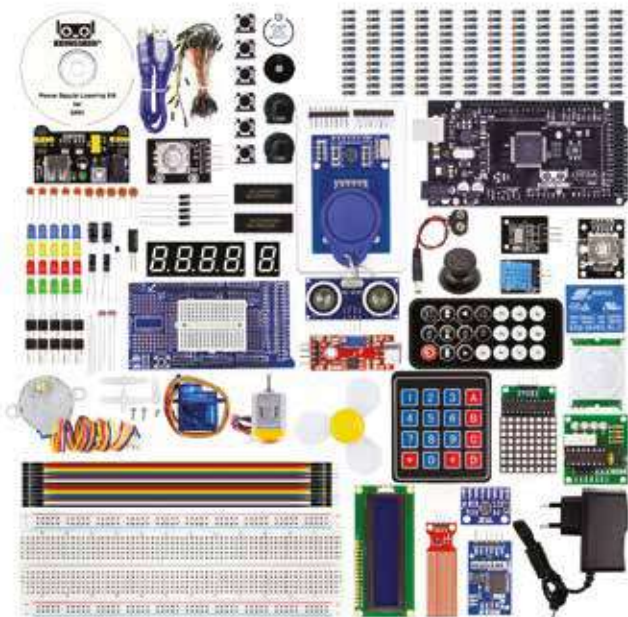

Microcontroller with sensors and accessories. Atmega2560 - the most complete Arduino starter kit VRO001

Set includes:

- 25x LED, (white, yellow, blue, red and green)
- 1x RGB led
- 10x ceramic capacitor (22 pf & 104 pf)
- 2x photoresistors
- 1x thermistor
- 5x rectifier diode (1N4007)
- 4x Electrolytic capacitor (10UF 50V & 100UF 50V)
- 10x NPN transistor (PN2222 & S8050)
- 1x tilt switch, 5x button (small)
- 1x 1 digit seven-segment display
- 1x 4 digit seven-segment display
- 1x sound sensor module, LCD1602 module (with pin header)
- 1x L293D integrated circuit, 74HC595 integrated circuit
- 1x active buzzer
- 1x passive buzzer
- 1x RTC module
- 1x DHT11 temperature and humidity sensor
- 2x potentiometer

- 1x rotary encoder module
- 1x joystick module
- 1x keyboard module
- 1x 5V relay
- 1x IR receiver module
- 1x MEGA2560 controller board
- 1 x prototype shield board
- 1x Servo motor (SG90)
- 1x stepper motor
- 1x stepper motor driver board ULN2003
- 1x prototype extension board
- 1x power module (warning: do not use voltage higher than 9V), 1x HCSR501 pir motion sensor
- 1x ultrasonic sensor
- 1x GY-521 module (with pin header)
- 1x 3V servo motor
- 1x MAX7219 module, remote control pilot (battery not included)
- 1x 9V power supply
- 1x jumper wire pack (65 wires)
- 1x water level sensor
- 1x USB cable
- 1x RC522 RFID module, 120x 10R/100R/220R/330R/1K/2K/5K/10K/100K/1M resistors
- 20x female-male Dupont jumper card



Microcontroller with sensors and accessories. RFID set - complete starter kit for Arduino VR0004

Complete RFID starter kit, perfect for exercises in expanding the knowledge of programming.

Set includes:

- 1x Components introduction documents
- 1x UNO R3 board
- 1x USB cable
- 1x jumper wire pack (65 wires), 30x (220R, 10K, 1K) resistor
- 1x 10 pin male-female Dupont jumper cord
- 1x potentiometer
- 1x active buzzer
- 1x passive buzzer
- 1x 74HC595N integrated circuit
- 1x infrared receiver
- 1x LM35DZ temperature sensor
- 1x flame sensor
- 2x ball switch
- 3x 5mm LDR
- 5x Tactile push button switch
- 1x Infrared remote control
- 1x 1 digit tube segment
- 1x 4 digit tube segment
- 1x 8x8 dot matrix
- 1x stepper motor driver board UNL2003
- 1x stepper motor



- 1x Servo motor (SG90)
- 1x LCD1602 display with IIC/I2C modules
- 1x Joystick module for PS2 games
- 1x DHT11 temperature and humidity sensor
- 1x water level sensor
- 1x RFID module
- 1x RFID keyring, 1x RFID card
- 1x sound sensor module
- 1x relay module
- 1x RTC module
- 1x matrix keypad module (16 buttons)
- 1x Three colour RGB module
- 1x 9V battery clip

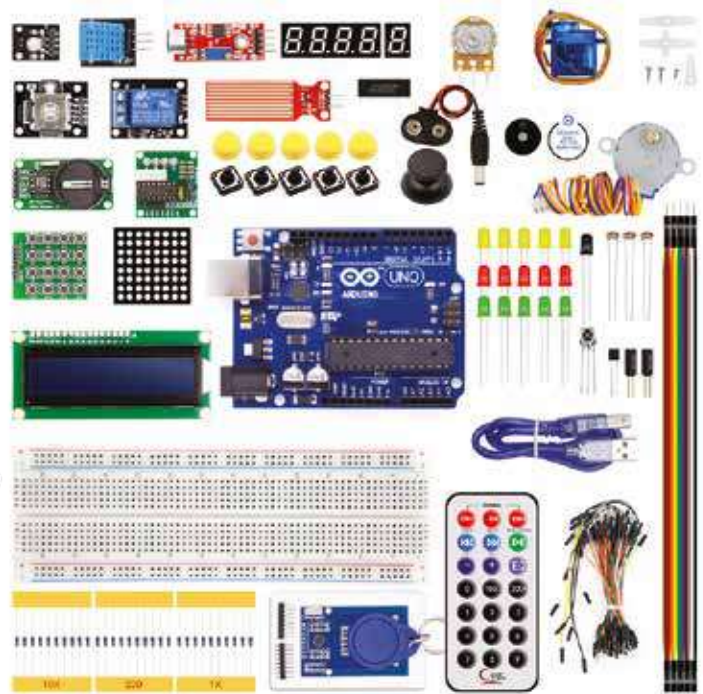

Microcontroller with sensors and accessories. The most complete guide for Arduino UNO R3 VR0003

Set includes:

- 25x LED, (white, yellow, blue, red and green), 1x RGB led, 10x ceramic capacitor (24 pf & 104 pf), 2x photoresistors, 1x thermistor, 5x rectifier diode (1N4007), 4x Electrolytic capacitor (10UF 50V & 100UF 50V), 10x NPN transistor (PN2222 & S8050), 1x tilt switch, 5x button (small), 1x 1 digit seven-segment display, 1x 4 digit seven-segment display, 1x sound sensor module, 1x blue LCD1602 module, 1x integrated L293D circuit, 1x integrated 74HC595 circuit, 1x active buzzer, 1x passive buzzer, 1x RTC module, 1x DHT11 temperature and humidity sensor, 2x potentiometer, 1x rotary encoder module, 1x joystick module, 1x keyboard module
- 1x 5V relay
- 1x IR receiver module
- 1x UNO R3 Controller Board

- 1x breadboard
- 1x Servo motor (SG90)
- 1x stepper motor
- 1x stepper motor driver board ULN2003
- 1x prototype extension board, 1x MB102 motherboard
- 1x 3.3V-5V power supply module
- 1x HCSR501 PIR Motion Sensor Green
- 1x Ultrasonic sensor
- 1x GY-521 MUP6050 module, 1x 3v dc motor with cable
- 1x MAX7219 module with cable, 1x remote control pilot (battery not included)
- 1x 9V 1A EU plug adapter
- 1x jumper wire pack (65 wires)
- 1x rainwater level detector
- 1x USB cable
- 1x 9V DC battery
- 1x RC522 RFID module
- 120x 10R/100R/220R/330R/1K/2K/5K1/10K/100K/1M resistors, 20x female-male Dupont jumper cord





Microcontroller with sensors and accessories. The biggest starter kit for Arduino

VR0006

Set includes:

- 1x Double layer storage box (dim.: 23,4 x 16,8 x 6,2cm);
- 1x UNO R3, 1x 1.64ft USB cable (0.5m);
- 1x LCD1602 display module (can be soldered);
- 1x Servo motor SG90 (9 g, 180°);
- 1x 830 points breadboard (can be soldered);
- 1x ULN2003 Driver Board (green);
- 1x IR remote control pilot (battery not included);
- 1x 28BYJ-48 5v 4-stepper motor;
- 1x jumper wire pack (65 wires);
- DS3231 AT24C32 IIC Module (battery not included);
- 1x . MFRC-522 RC522 RFID + S50 + card + RFID keyring;
- 1x 4x4 Matrix;
- 1x keypad module (16 buttons);
- 1x joystick module for PS2 games;
- 1x 1-Channel 5V Relay Module;
- 1x sound sensor module;



- 1x DIP 3 Colour LED Module;
- 1x DHT11 temperature and humidity sensor
- 1x rainwater level sensor module;
- 1x 0,56", red, 4 digit seven-segment LED display (12 pin);
- 1 x LED Matrix red 8x8 64 LED 3mm CA;
- 1 x 9 Volt Battery Adapter;
- 1 x 10Pin Dupont wire (male, female);
- 1 x CD guide;
- 1 x SMD 3-coloured LED modules;
- 1 x 170 points Mini Breadboard SYB-170 White;
- 1 x 3 in 1 resistor kit;
- 1 x LED pack



ROBOTS

Robot Smart Robot Car Uno R3 VR0007

Smart Robot Car Uno R3 is an intelligent robot used for educational purposes. The STEAM set was designed for beginners who are just starting their adventure with programming, electronics and robotics. Inside, there are 24 different modules, for example: obstacle avoidance, line tracing module, infrared remote control. The robot can be controlled via mobile devices with Android or IOS systems. Smart Robot Car Uno R3 is easy to assemble. A CD guide included in the set contains all necessary instructions on how to build the robot.

The kit consists of:

- 1 x UNO R3, 1 x USB cable, 1 x V5.0 extension board, 1 x L298N motor driver board, 1 x ultrasonic Sensor, 1 x ultrasonic holder, 1 x servo motor, 1 x Bluetooth module, 1 x IR receiver module, 1 x remote, 1 x charger, 1 x cell box, 1 x CD guide
- 4 x motor, 4 x wheels, 4 x aluminium blocks,
- 8 x screws, 38 x nuts, 6 x copper column, 6 x copper screws;
- 20 x Dupont wires;
- 3 x line tracing module;
- 2 x acrylics plates



Robot Smart Robot Car 4WD VR0008

Robot Smart Car 4WD is an intelligent robot-car which can handle rough conditions on the road or even drive on slopes. Modern solutions used to design the robot make it solid and the Arduino Uno programmable processor gives an opportunity to begin an adventure with programming, robotics, algorithmics or logic.

The set includes:

- Robot Smart Car 4WD Kit UNO R3 for Arduino; Line Tracing Module;
- Ultrasonic Module;
- IHC-05 Bluetooth Module



Set for pad construction

VR0010

RobotLinking is a creative programming kit for beginners. The Deluxe kit contains everything you may need to discover the world of programming. With the use of the Robotlinking creative keyboard, everyday objects will be transformed into a computer program. You can create a gamepad, banana bongos drums, a cardboard guitar which you can play as well as a vegetarian piano.

- 1 x Robotlinking Creative Keyboard
- 10 x DuPont wire;

- 1 x USB cable;
- 20 x cables with crocodile clips;
- 1 x expansion board;
- 1 x crocodile clip with a strap;
- 2 x 6B pencil;
- 1 x sharpener;
- 1 x double-sided tape;
- 1 x gummed paper;
- 2 x coloured clay (orange & green);
- 1 x thin conductive yarn – 4m;
- 4 x sponge;
- 1 x gummed paper with copper foil;
- 2 x paper controller;
- User's manual;
- age: 8+



Robot starter kit VR0011

An educational kit for beginners or advanced users who would like to start their adventure with Arduino programming. Thanks to the rich set of components compatible with open-source Arduino software, you can combine fun with learning. There are 17 worksheets with lists of components and circuit diagrams for each project included in the kit. Additionally, everything is kept in an aesthetic and practical plastic box that makes it easy to transport.

- Arduino Uno R3;
- prototype breadboard 400 connection points;
- prototyping shield;
- 30 male-male connector cables;
- 10 male-female connector cables;
- motion sensor PIR HCSR01;
- ultrasonic distance sensor HCSR04;
- temperature sensor LM35;
- battery cassette 6 x AA;
- IR remote controller;
- Fan motor 130;
- fan;
- 9G micro servo;
- 4 x buttons;
- 3 x potentiometer 10K;
- vibration sensor module;
- transmitter;
- infrared receiver;
- light sensor;
- 8-segment LED display;
- buzzer;
- 9 x 5mm LED;
- 1 x RGB LED;
- resistors 20 x 220R, 4,7K, 10K, 1K;
- 17 worksheets;
- plastic case;
- age: 8+





Small robot car VRO012

This kit was designed for those who would like to increase their practical and theoretical knowledge of the Arduino programming environment as well as robot building. You will be able to see with your own eyes how sensors, motor controllers and many other elements function, and you will learn how to build programmable devices. With the new skills, you make a multitasking robot that can avoid obstacles, identify the source of the strongest light and follow the commands sent to it via the remote control. Become a robotics master!

- Set of screws and nuts;
- Elements of the body; two wheels; Arduino UNO R69 RJ12;
- Remote controller;
- fan;
- screwdriver;
- clamping plates;
- insulating tape 5m x 18mm;
- Servo SG-90;

- USB cable;
- 2 x in-wheel motor;
- charger;
- mounting brackets;
- plastic third wheel;
- silicone battery extension cable;
- 5 x programming cable;
- battery cassette;
- 2 x joystick module;
- ultrasonic sensor;
- IR sensor;
- LED;
- touch module;
- power supply port;
- temperature sensor;
- buzzer module;
- DC servo motor;
- sound sensor;
- button;
- light sensor;
- traffic light module;
- laser LED;
- SMD RGB module;
- potentiometer;
- human pyrolysis sensor;
- plastic case;
- age: 12+



Educational kit with a robot, worksheets and lesson scenarios AJ7534

The starter kit for programming and robotics. It helps to create and achieve goals related to programming, robot control, computer skills, fun and educational activities. This kit is equipped with a variety of construction elements and sensors which allow the user to build realistic models and to simulate the use of devices in everyday life, e.g. traffic lights, catapult, electric car, automatic doors and others. Additionally, it offers

the opportunity to formulate hypotheses, solve them, look for solutions and correct errors - everything you need for programming. The kit contains 4 manuals and sets of scenarios. There are 4 scenarios in each set covering the following topics: Doors Automatic doors, Make a Light Show, Stop and Go, Make a Car - robot. A detailed illustrated manual for the student and a teacher's manual are also included. Students can work independently with the kit and educational materials. The robot can operate both in the test mode when it is directly connected to



4 lesson scenarios

the computer or autonomously after uploading the program into the Studuino memory. This kit also contains 24 two-sided worksheets. On the reverse are printed the commands for programming the robot, and on the front side, there are instructions on how to execute a program in Studuino with an example picture of a robot that a given program can execute. It is a complete teaching aid for both students and teachers. Perfect for a task or problem-oriented work as it encourages an independent search for answers and hypothesis testing.

- the kit contains: battery compartment, battery box,

servo motor, DC motor, open-source platform – Studuino – (Studuino software can be downloaded from a free domain), touch sensor, sound sensor, light sensor, infrared sensor, buzzer, 3 types of LEDs (red, green, blue), USB cable, 5 wires for connecting sensors, the buzzer and LEDs, 42 bricks in different shapes and sizes, 2 circles, 2 O-rings, rubber seals, a device for splitting the bricks; dim. of the box: 28 x 16 x 13 cm; software in English; age: 8+
 • system requirements: software: Windows XP (SP3 or later) / Vista 7,8, 8.1 / 10; Mac OS X (10.6 or later); CPU: Pentium 4, 2 GHz or higher (or equivalent); recommended: memory: 256 MB or more, USB: 2.0, screen resolution - XGA (1024 x 768) or greater

ART & CRAFT FURNITURE



Four-person easel
NS1729

- foldable, double-sided, accommodates 4 persons (4 trays) H 1,1 cm, boards 130 x 65 cm



Wall easel
NS0308

- size: 198 x 108 x 17 cm;
- sold without trays



Double-sided easel
NS0309

- large-sized, double-sided, serves for 6 children;
- size: 200 x 70 x 95 cm;
- sold without trays

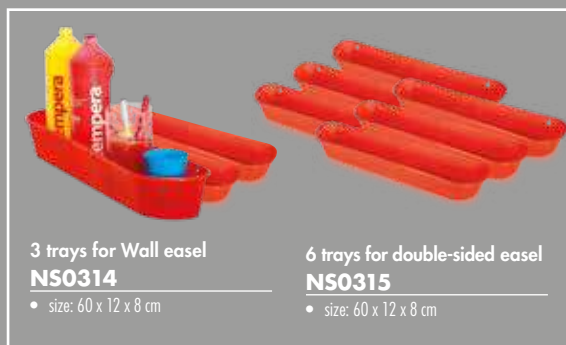

3 trays for Wall easel
NS0314

- size: 60 x 12 x 8 cm

6 trays for double-sided easel
NS0315

- size: 60 x 12 x 8 cm



Double easel
NS1728

- double-sided, foldable, for 2 persons
- (2 trays), H 1,1 m, boards 65 x 65 cm



Multipurpose stand
NS0578

Serves as a play corner; with accessories can be used as a puppet theatre (NS0580).

- glass painting corner (NS0581) or market stall (NS0579)
- size: 84 x 51 x 113,5 cm

Glazed frame
NS0581

Used with the multipurpose stand NS0578 to create an art corner.



Shelving unit Rainbow NS0464

A practical cabinet for sorting and storing art materials and accessories - on open shelves or in closed compartments or drawers. The whole consists of:

- an open top shelf 98 x 33 x 20 cm;
- a medium shelf 60 x 33 x 15 cm;
- 2 small shelves 29 x 33 x 30 cm;
- a compartment with a door 30 x 33 x 30 cm;
- a drawer 58 x 33 x 30 cm;
- the unit is made of laminated 18 mm chipboard in birch effect;
- the coloured elements are made of MDF and compartments of HDF;
- total dim: 98 x 33 x 1,2 cm



UNIVERSAL

A mobile cabinet for storing and keeping in order various art materials on shelves or in all-purpose trays. Storage space for large-size cardboard.

- a small open shelf;
- a large open shelf;
- 2 large cabinet shelves;
- 4 plastic trays (1 deep, 3 shallow);
- 2 long bins for paint bottles;
- dim.: of the cabinet without bins: 98 x 45 x 76 cm;
- dim.: of the cabinet with bins: 98 x 58 x 76 cm

materials:

- framework: laminated particle board in birch colour;
- fronts: MDF board in green colour; milled;
- 4 castors (including 2 with a lock facility)



4 plastic trays:
1 deep and
3 shallow

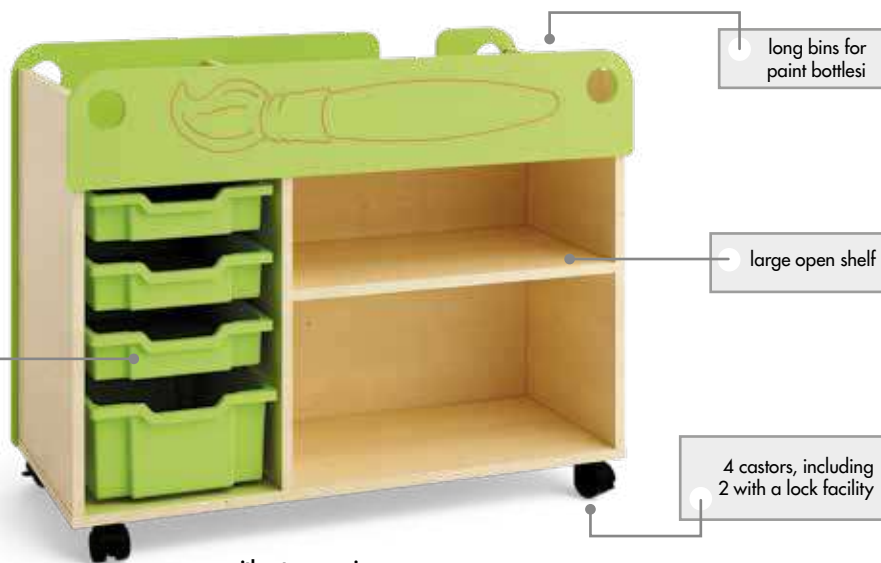

- without accesories
NS0782



two-sided



- with accessories

NS0783

Contains:

- white drawing paper 250 pcs
- white technical drawing paper A3 100 pcs
- colour paper mix 25 pcs
- craft tissue paper 30 pcs
- class pack long crayons 300 pcs
- tempera 1l 6 pcs
- sponge brushes 4 pcs
- brushes standard mix 24 pcs
- plasticine classpack 180 sticks
- vinilic glue 1l 1 pc
- chenille stems 100 pcs



colour paper mix

white technical drawing paper A3
white drawing paper A4

craft tissue paper 30 pcs



vinilic glue 1l



tempera 1l 6 pcs



sponge brushes



brushes 24 pcs.



plasticine classpack 180 sticks



class pack long crayons



chenille stems 100 pcs

Colourful and functional cubboards are a convenient way of organizing and storing all kinds of art materials. The variety of drawers, containers and cabinets guarantees efficient use of space. Besides, they are easy to use and they help reduce the load in schoolchildren's backpacks. Storage units on castors help move and organize classroom tools and materials according to current needs.

Cubo NC4000

A double-sided mobile cabinet from the Cubo series for art materials. The cabinet has 3 tiers and 4 types of shelves:

- size: 36 x 17 x 36 cm;
- 2 cabinet shelves 36 x 35 x 36 cm, whole unit 114 x 39 x 87 cm;
- framework: laminated particle board in birch colour;
- dividers: laminated particle board in turquoise, key lime or grey colour;
- 5 castors (including 2 with a lock facility);
- sold without art & craft materials



Front



More furniture
available on page 76



Back





with MDF lid



**Table with container
NS0565**

- central part of the top hides a container for small objects necessary in art & craft activities;
- size: 120 x 80 cm, 3 H: 46, 52, 58 cm



**Mobile activity table
NS0594**

- size: 62,5 x 67 x 42 cm
sold without accessories



**Art cabinet on wheels
NS0781**

- size: 80 x 75 x 40 cm
sold without accessories

ARTS & CRAFTS CLASSROOM SET

Therapy through art allows the use of many different forms of artistic expressions. By sculpture, painting, drawing, singing, playing instruments the therapist can address the patient's feelings, emotions, needs and fears. This form of therapy is suitable for everyone, regardless of age, and it can equally serve children, adults and the elderly. The patients are not required to have any artistic skills as the creative process itself has a therapeutic effect. In order to facilitate the implementation of art therapy, we present a wide selection of inspiring products such as, sets of high-quality crayons, dry pastels, paints, decorative cardboards and drawing papers as well as origami and quilling tools. We also offer a large variety of musical instruments from tambourines, flutes, maracas, castanets to bells which

can introduce the elderly to the world of sounds. Through different techniques, fine art therapy helps patients to discovering and developing their talents, skills or predispositions. thanks to this, it supports the therapeutic process as well as personal development. With a view to provide the elderly with all the equipment they may need to be artistically fulfilled, we prepared a special offer of creative art materials. Among them can be found well selected products intended for those who want to learn to paint or draw as well as colourful materials dedicated to creating decorations and ornaments. We offer all kinds of punches, modelling pastes, crepe papers and paint pens for porcelain. For scrapbooking, decoupage, quilling or origami, we provide professional tools and accessories.



Art starter kit TM2006

Rich set of art supplies for the realisation of creative projects. This set allows teachers or therapists to prepare interesting art classes. Thanks to such activities it is possible to develop unique ideas and creativity, while maintaining good manual dexterity.

The set contains:

- 1 x Set of papers,
- 2 x White A4 drawing paper,
- 1 x 11 Tempera paints in 6 colours,
- 1 x 11 Tempera paint in black,
- 1 x Ceramic paints,
- 1 x Oil pastels. Set,
- 1 x Stained glass paints,
- 1 x Origami triangle,
- 1 x Origami square,
- 1 x Small origami circles,
- 1 x Set of 60 pcs. long thin colour pencils,
- 1 x 11 Universal glue,
- 1 x Set of 12 professional flat brushes,
- 1 x Set of 12 professional round brushes,
- 1 x Plaster,
- 1 x Coloured pompons,
- 1 x Set of feathers,
- 1 x Sequins in a case,
- 1 x Quilling set for the whole year,
- 1 x Water containers for paints,
- 1 x Scissors,
- 1 x Ceramic pots for decoration,
- 1 x Vases for decoration,
- 1 x Crepe paper – mix



Nursery art starter kit TM2004

Set of art supplies for toddlers necessary for the realisation of their creative projects. This set allows teachers to prepare interesting classes using various art techniques.

The set contains:

- 1 x A4 xero coloured paper,
- 1 x A3 drawing paper, 100 pcs;
- 1 x A4 coloured cardboard;
- 1 x Coloured cardboard. Dots and lines;
- 1 x Classroom set of thick crayons, 60 pcs.;
- 1 x A4 coloured metallic corrugated cardboard,
- 1 x Origami paper – animals,
- 1 x Crepe paper – mix, 10 pcs.;
- 1 x Aiko eco paints, 6 x 0,5 l paint;
- 1 x Finger paints, 6 x 100 ml;
- 1 x Water container for paints, 6 pcs.;
- 1 x Animal texture stamps, 4 pcs.;
- 2 x Paint stand;
- 1 x Texture stamps, 6 pcs.;
- 2 x Barrel brushes for toddlers, 5 pcs.;
- 1 x Classroom set of play-doh, 180 pcs.;
- 1 x Modelling clay in cubes, 12 pcs.;
- 1 x Craft glue, 1000 ml;



Afterschool club art starter kit TM2005

Set of supplies necessary for the realisation of art projects at the after-school clubs. This set allows children to discover various art techniques.

The set contains:

- 1 x A4 xero coloured paper;
- 1 x A3 drawing papers, 100 pcs;
- 1 x A4 coloured cardboard;
- 4 x Triangle colour pencils, 12 pcs.;
- 1 x Classroom set of crayons;
- 1 x Aiko eco paints, 6 x 0,5 paint;
- 4 x Paint palettes;
- 1 x 9 mm Standard flat brushes, 8 pcs;
- 1 x 8 mm Standard flat brushes, 8 pcs;
- 4 x 35 g Glue sticks,
- 1 x Classroom set – play-doh, 180 pcs.;
- 1 x Universal glue, 1l;
- 2 x Crepe paper – mix;
- 1 x Coloured creative wires, 100 pcs.;
- 1 x Stained glass paper;
- 1 x Feathers, 150 pcs.;
- 1 x Coloured pompons, 100 pcs.;
- 1 x Eyes, 560 pcs.;

ARTS AND CRAFTS CLASSROOM PACK



Our packs are big, practical sets of various arts and crafts materials for groups of 25 and 5 children. High quality crayons and paint with intense colours, white and colourful drawing pads in

different thickness and texture, handy paint brushes with wooden handle, plasticine in 12 colours, folders for works and many more aids which enable creative activities throughout the year.



Annual Classroom pack for 25 kids

TM2010

Components:

- Vintilic glue 1L, 1 pc
- Tempera 1L, 6 colours
- White drawing paper A4, 750 sheets
- Plasticine class pack, 2,4 kg
- Bottle dispensers, 25 pcs
- Colour paper A3 (15 colours), 60 sheets
- Colour drawing paper A3, 100 sheets
- White bristol A3, 100 sheets
- Standard brush round 4mm, 7 pcs
- Standard brush flat 9mm, 7 pcs
- Standard brush round 8mm, 11 pcs
- Coloured pompons 100 pcs
- Self-adhesive foam foil, 10 sheets
- Punch with different designs (4 patterns)
- Tissue-paper Cow, 1 roll
- Tissue-paper Leopard, 1 roll
- Corrugated tissue-paper, 10 pcs in 10 colours
- Beige corrugated paper, 50 sheets
- Folder, 25 pcs
- Colour corrugated paper, 10 pads
- Class pack crayons 300 pcs, 12 colours
- Colour moving eyes, 100 pcs
- Wax crayons, 12 colours, 25 sets
- Plain tissue-paper, 30 sheets
- Cut-out paper A4, 130 sheets
- Chenille Stems, 100 pcs

- **Big quantity drawing paper**
- **Well covering paint**
- **Top quality triangle pencils**



- **Vivid colours**
- **Paper for all occasions**
- **Big bottle of vinilic glue**

Art kit add-on TM2110



An extension to the art kit.

It contains:

- 6 different tempera paints (1 l)
- 1 universal glue (1l)
- 250 A4 sheets of drawing paper
- 15 A3 sheets of coloured cardboard
- 150 A3 sheets of coloured drawing paper
- 100 A3 sheets of Bristol board
- 10 sheets of mixed tissue paper (200 x 50 cm)
- 25 A4 sheets of white Bristol board
- 30 sheets of tissue paper in 10 colours (50 x 70 cm)
- 130 A4 sheets of glossy paper in 10 colours
- 96 thin long crayons in 4 colours:
red, yellow, blue, green
- 120 sticks of plasticine in 4 colours:
yellow, green, blue, red



PAPER



White drawing paper A3 TM0002

- 250 pcs;
- 90–100 g/m²

White drawing paper A4 TM0001

- 250 pcs;
- 90–100 g/m²



Drawing pad

- 90–100 g/m²

A4

TM2018

- 20 sheets

A4

TM2028

- 50 sheets

A3

TM2043

- 20 sheets

Technical drawing pad

- 190–200 g/m²

A4

TM2020

- 10 sheets

A4

TM2029

- 30 sheets

A3

TM2046

- 10 sheets

A4

TM2047

- 20 sheets

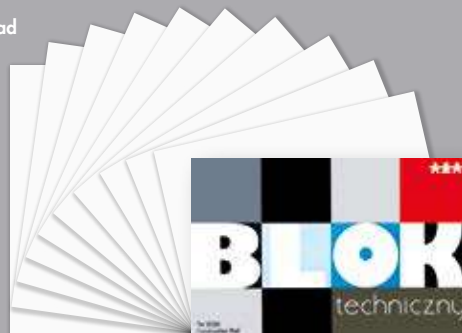

Black drawing pad

- 190–200 g/m²

A4

TM2027

- 10 sheets

A3

TM2060

- 10 sheets

Colour paper

- 80 g/m²

A4

TM2021

- 10 sheets

A4

TM2031

- 20 sheets

A3

TM2049

- 20 sheets





Technical colour drawing pad

- 190–200 g/m²

A4

TM2025

- 10 sheets

A4

TM2032

- 30 sheets

A3

TM2061

- 10 arkuszy

A3

TM2062

- 20 sheets

A3

TM2058

- 100 sheets



Colour drawing pad

- 90–100 g/m²

A4

TM2019

- 10 sheets

A4

TM2030

- 30 sheets

A3

TM2045

- 20 sheets

cover can
be customized

PAINTS

Wall rack

MT5460

A wall drying rack for drying children's paintings.

- will hold 20 works;
- size: 50 x 40 x 62 cm;
- powder-coated;
- foldable

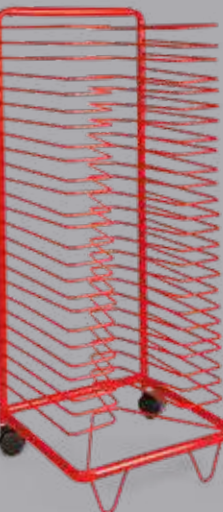
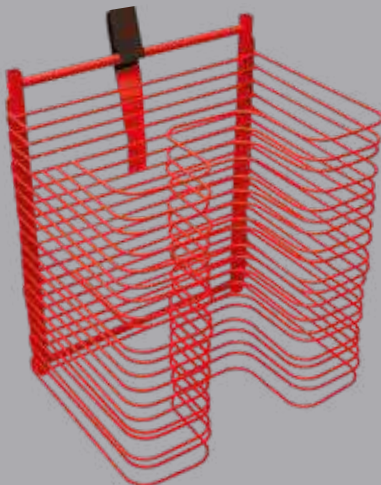

Large-sized

MT5457

- 25 levels;
- size: 43 x 33 x 90 cm;
- on casters



Fluorescent sticky paper

- 180 g/m²

A4

TM2023

- 10 sheets

Large

TM2024

- 10 sheets;
- size: 24,5 x 33,5 cm



Rainbow paper A4

TM2022

- 10 sheets;
- 80 g/m²



Small-sized

MT5455

- 17 levels;
- size: 43 x 33 x 65 cm;
- on casters

TEMPERAS



**Tempera 0,5 l. 6 colours
NS0800**

- 3 l
- cardboard box



**Tempera 1 l. 6 colours
NS0802**

- 6 l
- cardboard box

TEMPERA PAINT

Tempera paint to be used without adding water. It was made of high-quality pigments which guarantee light resistance and colour intensity. The paint washes off easily. It can be freely mixed with other colours.

0,5L



- Nude
RL1758



- Black
RL1100

1L



- Turquoise
RL0757



- Fuchsia
RL0755



- Pink
RL0756



handy holder

bottle with dispenser
perfectly covering
and long-lasting colors
intensive colors



0,5 l



1 l

ECO PAINTS

All-purpose cost-efficient watercolours in six basic colours. An economic alternative to our excellent temperas. Intended for paper, canvas, plaster, wood, styrofoam. The snap-on cap helps dispense the paint.



0.5 l - 6 colours
LF0020



1 l - 6 colours
LF0001



Plastic trays 4 pcs
AP2095

- 4 pcs, size: 16 x 12 x 4 cm
- covers can be customized



Extra safe non spill pot
AP2325

- Plastic pots with wide bottom to hold water and brushes. The concave funnel-shaped top prevents spilling out.
- 6 pcs in 6 colours; age: 3+



Small plastic pad
NS0418

- size: 24 x 33 cm



Big plastic pad
NS0389

- size: 40 x 60 cm



Set of 3 art smocks with long sleeves
NS8133

- 3 pcs; size: 42 x 45 cm; long sleeve; fabric: polyester;
- colour: blue, green, yellow



Set of 3 art smocks
NS8801

- 3 pcs; D 24 cm; long sleeve; fabric: polyester
- colour: blue, green, yellow



Bottle Dispensers
RL0754

- Dispensers for paint or glue.
- capacity 25 ml, 5 pieces

BRUSHES

STANDARD

- fur: pig
- wooden handle



Mix
NS1035

- 24 pcs



Round 4 mm
NS1036

- H 16,7 cm, 8 pcs



Round 8 mm
NS1037

- H 17,2 cm, 8 pcs



Flat 5 mm
NS1040

- H 16,7 cm, 8 pcs



Flat 9 mm
NS1041

- H 17,2 cm, 8 pcs



Flat 15 mm
NS1042

- H 17,9 cm, 8 pcs



Flat 20 mm
NS1043

- H 18,4 cm, 8 pcs



Round 12 mm
NS1078

- H 16,7 cm, 8 pcs

PROFESSIONAL

- fur: nylon
- wooden handle

Round mix NS1044

- 12 pcs



Flat mix NS1045

- 12 pcs



FLAT

- fur: nylon
- wooden handle

Mix NS1055

- W 24, 40, 60 mm, 12 pcs



UNIVERSAL

- fur: goat
- wooden handle

11 mm 24 pcs NS1051

- H 18,7 cm



11 mm 8 pcs NS1050

- H 18,7 cm



60 mm NS1054

- H 18,2 cm, 3 pcs



40 mm NS1053

- H 17,7 cm, 4 pcs



24 mm NS1052

- H 17,2 cm, 6 pcs





**18 mm
NS1047**

- H 16,7 cm, 5 pcs



**Non drip brushes
NS1070**

- set of 8 pcs (tip L 1,3 cm), bleached bristle
- plastic red handle



**Sensory brushes with big handles
AP2335**

Set of stamps and brushes which help to develop creative thinking and motor skills. All supplies are equipped with a comfortable stamp. Stamps can be

used with paints or modelling clay. They are made of durable plastic that can be reused.

- 6 pcs: 3 stamps (small dots, parallel lines, large studs), 3 brushes (short and round, wide and flat, long and round);
- dim. of the product: 16 x 4 x 12 cm; age: 3+



**Individual set
NS1079**

- universal brush, fur: goat;
- standard round 4 mm brush, fur: pig;
- standard flat 9 mm brush, fur: pig;
- professional flat 19 mm brush, fur: nylon;
- wooden handles



**Sponge brushes
NS1056**

- 4 pcs



RUBBER & FOAM ROLLERS

RUBBERY ROLLERS

Rubber rollers with spikes and grooves for painting and imprinting patterns in Play-Doh or similar compounds

- 3 pcs;
- roller diameter 4,5 cm;

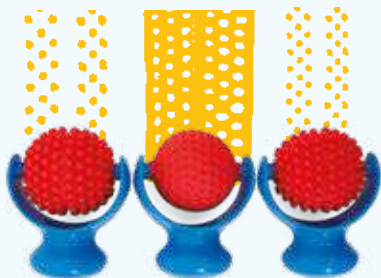

Spots
AP0874



Mixed Patterns
AP0875



Foam rollers
AP2111

- size: 7 cm, 4 pcs in 4 colours



Rollers with pattern
AP0406

- size: 7 cm, 3 pcs

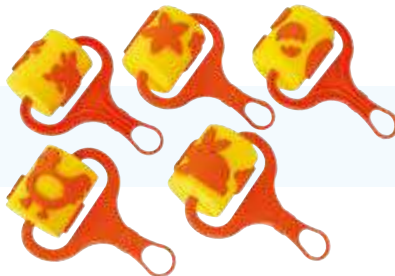

Easter
AP0731

- size: 15 cm, 5 pcs



City
AP0704

- size: 15 cm, 5 pcs



Christmas
AP0732

- size: 15 cm, 5 pcs



Sea
AP0730

- size: 15 cm, 5 pcs



Farm
AP0729

- size: 15 cm, 5 pcs

CRAYONS



8,8 cm (real size)



0,7 cm



0,8 cm



1 cm

17,5 cm (real size)



Jumbo long crayons
NS0803

- 12 pcs, ø 1 cm, L 17,5 cm



Watercolour pencils
NS0804

- 12 pcs ø 0,7 cm, L 17 cm and a brush



Long crayons 12 pcs
NS1057

- 12 pcs, ø 0,8 cm, 17,5 cm



Long crayons 24 pcs
NS1058

- 24 pcs, ø 0,8 cm, 17,5 cm



Jumbo short crayons
NS1059

- 12 pcs, ø 1 cm, L 8,8 cm



CLASSPACKS JUMBO



Jumbo short 60 pcs
NS1060

- 60 pcs, ø 1 cm, L 8,8 cm;
- 12 colours x 5 pcs



Jumbo long 60 pcs
NS1062

- 60 pcs, ø 1 cm, L 17,5 cm;
- 12 colours x 5 pcs



Jumbo long 300 pcs
NS1068

- 300 pcs, ø 1,2 cm, L 17,5 cm;
- 12 colours x 25 pcs

REGULAR

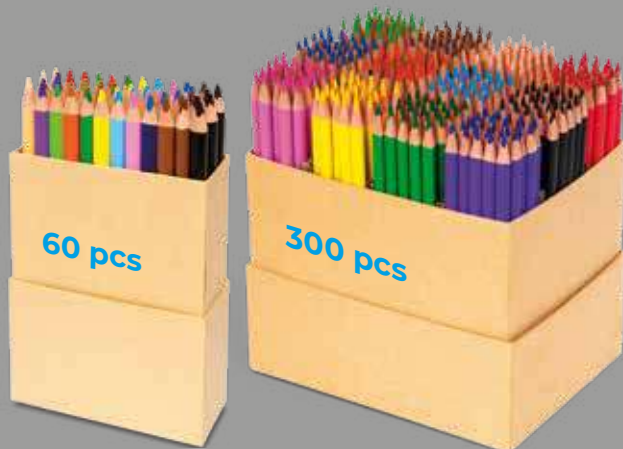

Long 60 pcs
NS1069

- 60 pcs, ø 0,8 cm, L 17,5 cm;
- 12 colours x 5 pcs

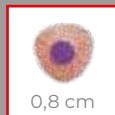

Long 300 pcs
NS1064

- 300 pcs, ø 0,8 cm, L 17,5 cm;
- 12 colours x 25 pcs



ONE COLOUR SETS

- 24 pcs, ø 0,8 cm, 17,5 cm

Blue
NS1090

Green
NS1091

Yellow
NS1092

Red
NS1093





WAX & OIL PASTLS

Jumbo wax class pack NS1065

- 300 pcs, ø 1,1 cm, L 9 cm;
- 12 colours x 25 pcs;
- box size: 25 x 19 x 10 cm



Oil pastel crayons - class pack**NS1077**

Large soft velvety crayons for paper, Bristol board, primed canvas, wood or plaster. The drawn lines are easy to smudge and colours easy to blend.

- 300 pcs, ø 8 cm, L 9 cm;
- 12 colours x 25 pcs;
- packed in an eco-friendly durable box with a top lid

**OIL PASTELS****- 12 colours****FC1200**

- ø 0,8 cm, L 9 cm

- 25 colours**FC1250**

- ø 0,8 cm, L 9 cm

**OIL PASTELS XL****- 12 colours****IG2930**

- ø 1,1 cm, L 7 cm

- 24 colours**IG2931**

- ø 1,1 cm, L 7 cm





Wax crayons
RL3698

- 12 pcs; ø 0,8 cm, L 8,8 cm



Giant crayon marker
AP2060

- Draw with 4 colors at one time!
- ø 14,5 cm, age: 2+

Crayons refills
AP2084

- set of 6 colors
- ø 5 cm
- age: 2+

Easy grip crayons
AP2023

- set of 6 colors
- ø 5 cm, L 6 cm
- age: 2+



CHALK



Chalk with round handles

AP2082

A set of colourful chalks with handles designed with little hands in mind. The product is especially recommended for children with special educational needs.

- 6 chalks with handles; dim.: 6 x 4,5 cm;
- interchangeable chalk refills



Chalk refills for round handles

AP2083

A set of chalk refills for handles.

- 6 pcs;
- diam.: 5 cm

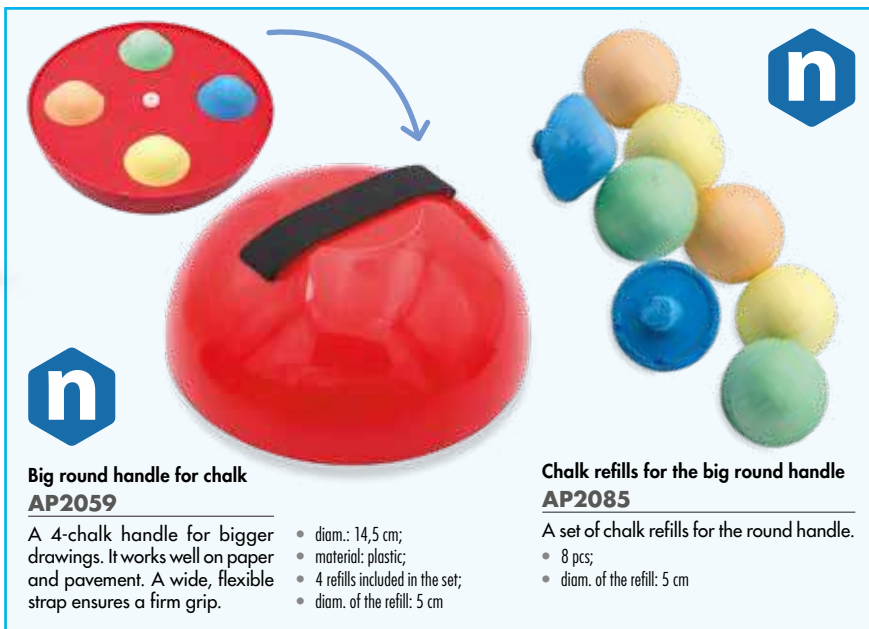

Big round handle for chalk

AP2059

A 4-chalk handle for bigger drawings. It works well on paper and pavement. A wide, flexible strap ensures a firm grip.

- diam.: 14,5 cm;
- material: plastic;
- 4 refills included in the set;
- diam. of the refill: 5 cm

Chalk refills for the big round handle

AP2085

A set of chalk refills for the round handle.

- 8 pcs;
- diam. of the refill: 5 cm

STAMPS

Wooden stamps from Nowa Szkoła are perfect for preschool and primary education. They might come in handy during arts and crafts lessons as well as maths, biology, and languages classes. The stamps develop imagination, creative abilities and improve hand-eye coordination.

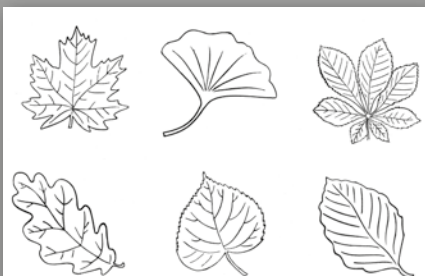

Leaves
DN2621

• size: 6,5 x 7 cm

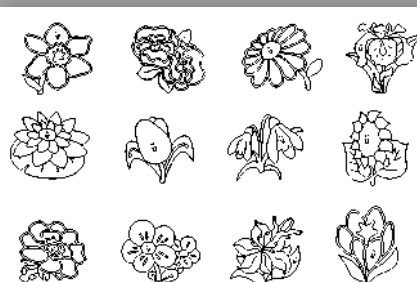

Flowers
DN2626

• 12 pcs; size: 5 x 4 cm

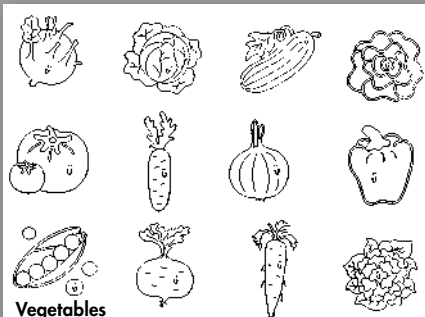

Vegetables
DN2627

• 12 pcs; size: 5 x 4 cm

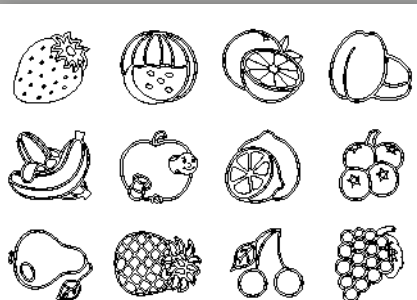

Fruit
DN2628

• 12 pcs; size: 5 x 4 cm

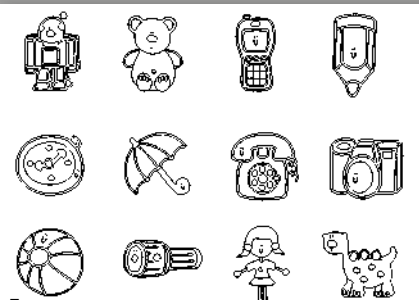

Toys
DN2629

• 12 pcs; size: 5 x 4 cm



Animals around us
DN2630

• 12 pcs; size: 5 x 4 cm



Garden
DN2644

• 12 pcs; size: 5 x 4 cm

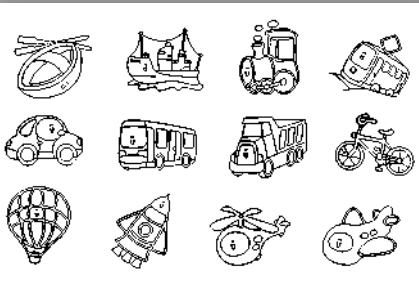

Vehicles
DN2625

• 12 pcs; size: 5 x 4 cm

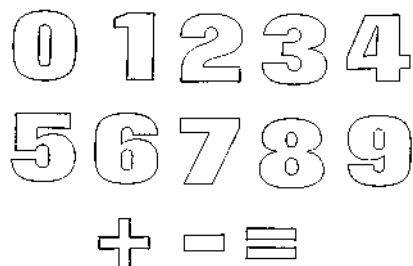

Digits
DN2635

- 10 pcs; size: 5 x 4 cm



Alphabet
DN2638

- capital print letters; 26 pcs; size: 1,5 x 2,4 cm



Forest
DN2645

- 12 pcs; size: 5 x 4 cm



Farm
DN2647

- 12 pcs; size: 5 x 4 cm



Christmas
DN2622

- size: 6,5 x 7 cm

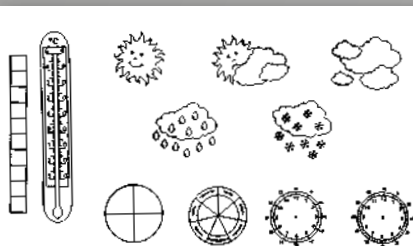

Weather and Time
DN2646

- 9 pieces 5 x 4,3 cm; 2 pieces 2,5 x 12 cm

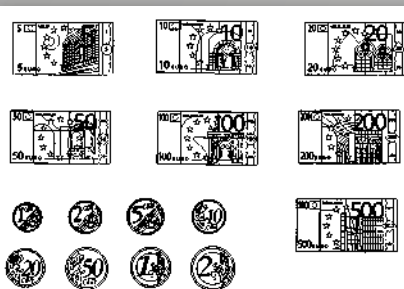

Euro
DN2658

- 15 pieces of coins and banknotes; size: 3,5 x 3 cm – 7,5 x 4 cm

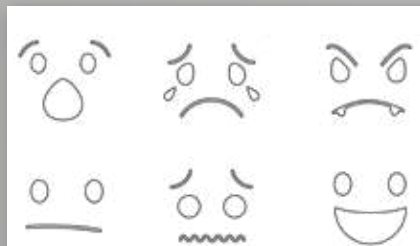

Emotions
DN2634

- 6 pcs, 6,5 x 7 cm



Ink pad green
AP0493

- ø 15 cm

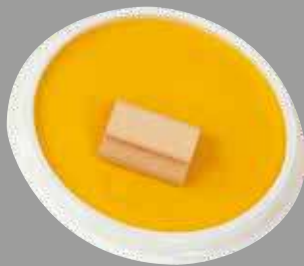

Ink pad yellow
AP0495

- ø 15 cm

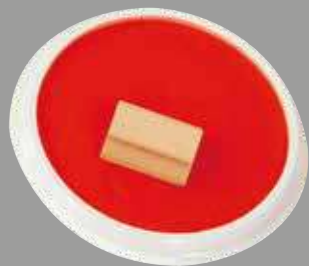

Ink pad red
AP0494

- ø 15 cm

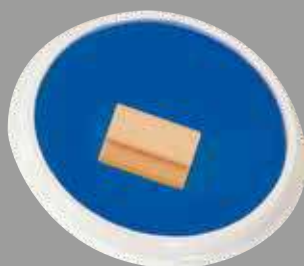

Ink pad blue
AP0488

- ø 15 cm



Four Part paint pad set
AP2285

- size: 20 x 20 cm;
- 4 sponge colors



Ink-pad silver
AP2449

- 1 pc;
- size: 7 x 7 cm



Paint pots for stamping AP2535

Coloured paint pots for creating paintings with dots or for filling bigger spaces. Their unique design with a comfortable ball-shaped handle makes them easy to use and

suitable for toddlers. Perfect addition to any creative activity with stamps. They can be stored in a cardboard box with a tray. The set allows a group of children to play together.

- 24 pcs;
- colours: red, yellow, blue, green, orange, purple;
- material: plastic; age: 3+

RUBBER PALM PRINTERS



- Small AP0848

Round rubber stamps for fingers: small regular spots. Using paint or Play-Doh

the following textures can be obtained: rings, strips, rhombs, wavy lines, tangled lines, spots, stars, a flower.

- 8 elements stamp diameter 3 cm



- Large AP0861

A set of multi-colour stamps with different textures: small regular

spots, irregular small and large spots, tangled lines and stars. Each stamp has a handy strap for a firm grip.

- stamp diameter 6 cm, thickness 7 cm;

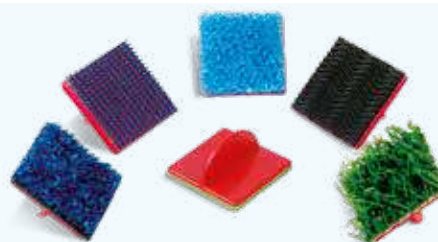

Stamps with patterns AP0434

- 6 pcs



Animal texture stamps AP2090

- 4 pcs, size: 6 x 5 x 5 cm

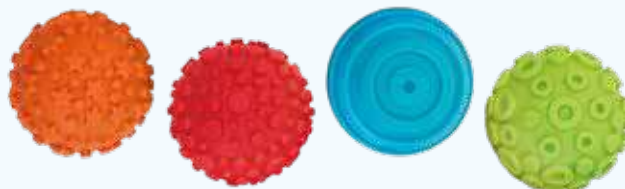

Sensory balls for modelling compounds and paint AP2416

Large rubber balls with different textures for printing patterns in Play-Doh, clay or with paint

- 4 pcs; D 6 cm; patterns: stars, rings, lines, spots



Easy-grip letter stamps AP2342

- set of 26 upper case letters;
- ø 4 cm

PLASTICINE



2,4 kg

Plasticine class pack TM2011

- 12 colour sets of 15 sticks each;
- 2,4 kg



Plasticine (multicolour) TM2015

- 6 sticks in different colours

Plasticine (multicolour) TM2050

- 12 sticks in different colours



Worksheets for plasticine NS4202

Graphic step-by-step instructions. Level of difficulty marked with stars. Each sheet features a different figure. One sheet is a colour sampler and provides instructions how to obtain secondary colours.

- 24 pcs;
- size: 11 x 23 cm



PUNCHES



ø 1,8 cm



Bear
KE1809



Christmas tree
KE1813



Maple leaf
KE1830



Snowflake
KE1833



Ribbon
KE1820



Clover
KE1821



Tulip
KE1826



Flower
KE1819



Butterfly
KE1805



Hare
KE1811



ø 2,5 cm



Angel
KE2529



Christmas tree
KE2501



Sweet
KE2533



Maple leaf
KE2512



Butterfly
KE2521



Heart
KE2516

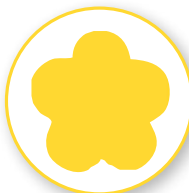

Flower 1
KE2511



Flower 2
KE2528

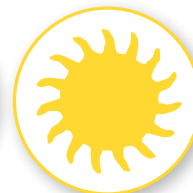

Sun
KE2503



Snowflake
KE2502



ø 3,2 cm

Christmas tree
KE3216



Star
KE3201



Clover
KE3214



Sun
KE3213



Tulip
KE3217



Flower
KE3221



EDGE PUNCHES



Houses
KE0012



Ribbon
KE0015



Wave
KE0018

PAPER CRIMPERS



Wave
KE8013



Teddy bears
KE8014



Flowers
KE8015



Hearts
KE8011



Stars
KE8012

PRESS PUNCHES

Heart
KE8202



Punch with different designs
KE8601

• 4 pcs

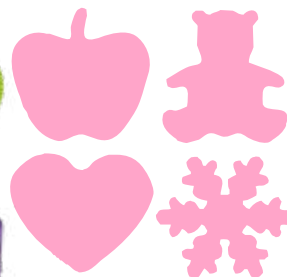

SCISSORS



Long scissors SN4000

- 21 cm, 1 pc.



Multipurpose scissors SN0002

- 21 cm, 1 pc.



Office scissors OP0012

- 16 cm, 3 pcs



Plastic scissors SN0005

- 12 cm, 5 pcs



Scissors SN0505

- 14 cm, 5 pcs





**Ergonomic scissors
SN0001**

• 13 cm, 5 pcs



**Scissors
SN7200**

• 14 cm, 4 pcs



**Ergonomic scissors
SN0007**

• 13 cm, 5 pcs



**Plastic scissors with patterns
SN0006**

• 13 cm, 3 pcs



**Scissors
SN7500**

• 16 cm, 3 pcs



GLUE



**Vinilic glue
NS0809**

• 0,5l



**Vinilic glue
NS0808**

• 1l



**Kids' glue
RL0405**

• 1l; age: 2+

STENCILS

- 6 shapes
- size: 15 x 15 cm



Christmas decorations

NS0910

- 6 shapes of christmas decorations



Christmas

NS0918

- candle, Christmas tree, nativity scene, bauble, snowman, sock

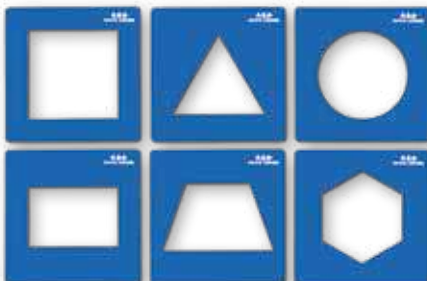

Geometric shapes

NS0912

- square, triangle, circle, rectangle, trapezium, hexagon



Easter

NS0919

- lamb, hare, catkins + daffodil, basket, Easter egg, chicken



Flowers

NS3020

- crocus, water lily, rose, daisy, lily of the valley, daffodil



Emotions

NS0914

- joy, sadness, fear, anger, surprise and lack of emotion



Garden

NS0916

- butterfly, tulip, watering can, snail, pumpkin, sunflower



Vegetables
NS0922

- carrot, tomato, lettuce, pepper, beetroot, peas

Fruit
NS0920

- banana, plum, strawberry, cherry, pear, apple



Forest
NS0915

- fox, hedgehog, boar, roe deer, beetle, owl

Farmyard
NS0925

- horse, cow, pig, ram, cat, dog



Stencils Emotions
NS0914

- 6 pcs; size: 15 x 15 cm



Toys
NS0923

- hare, dog, bear, airplane, car, duck



Mandala template**AP2537**

Set of templates for drawing mandala. Perfect for use with paints, crayons and felt tip pens. In order to use it, place the template on a flat surface and trace the pattern. These reusable templates are made of white durable plastic and they are easy to clean. They are also perfect for developing creativity and eye-hand coordination.

- 6 pcs;
- dim.: 15 x 15 cm;
- material: plastic;
- age: 3+

**Birds****NS0921**

- pigeon, turkey, duck, goose, hen, cock

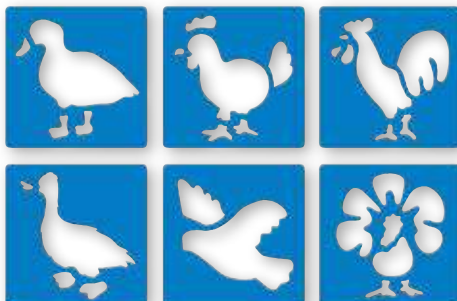
**Leaves****NS0913**

- maple, chestnut, beech, oak, linden, gingko

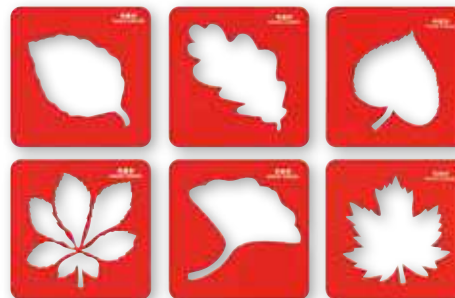
**Maxi Faces****NS0911**

- 6 head shapes

**Bugs and snail****NS0950**

- size: 15 x 15 cm

**Frame****NS0927**

- 6 shapes A4 size

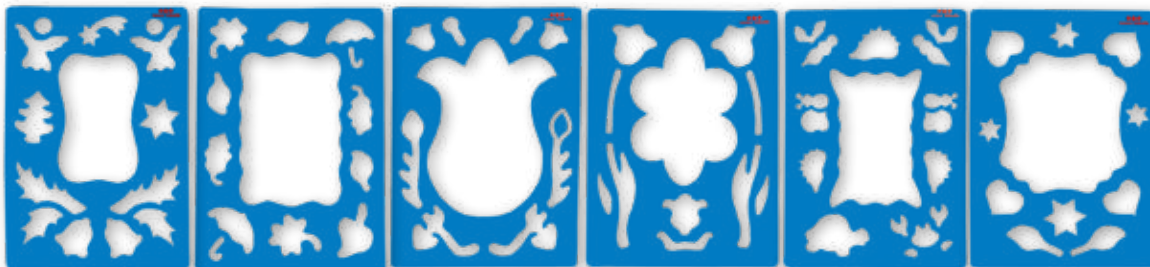

DECORATION



Eyes stickers
AP2528

Colourful stickers in the form of eyes in several designs. These stickers are perfect for the realisation of art projects. They can be used to decorate handmade dolls, greeting cards or other art works as it is possible to stick them to different surfaces: paper, wooden spoons or sticks, pompons, polystyrene shapes.

- 240 cardboard stickers; diam. of the eye: 1,2-1,7 cm;
- dim.: of the sheet: 15 x 22 cm; age: 3+



Felt flowers
AP2464

- set of 100 felt flowers for decoration



Cotton string
AP0002

- 200 m long cotton string



Self-adhesive eyes
AP1001

Self-adhesive eyes of different designs and sizes. Perfect for decoration and creative art projects.

- 100 pcs



Decorative lampshades.
Classroom kit
AP2540

Paper lantern with a diam. of 20 cm. Perfect aid during art classes. Lanterns can be decorated with paints, fibre-tip pens, stickers, glitter, etc. They are delivered in a flat packaging with metal frame.

- 10 pcs



Styrofoam hearts. Classroom kit
AP2524

Styrofoam hearts to decorate with various art techniques. They can be used as a base for different souvenirs or headdresses. The set of 20 hearts.

- dim.: 4 x 2 cm



Styrofoam stars.
Classroom kit
AP2526

Styrofoam stars to decorate with various art techniques. They can be used as a base for different souvenirs or headdresses. The set of 20 stars.

- dim.: 6 x 2,4 cm



Styrofoam Christmas trees.
Classroom kit
AP2527

Styrofoam Christmas trees to decorate with various art techniques. They can be used as a base for different souvenirs or headdresses. The set of 20 Christmas trees.

- dim.: 7,5 x 2,7 cm



Colour eye AP2049

Five stackable pots of coloured eyes in assorted colours and sizes.

- 500 pcs



Making Bugs AP2319

24 bodies in 3 different designs.

- body size: 62 x 15 mm

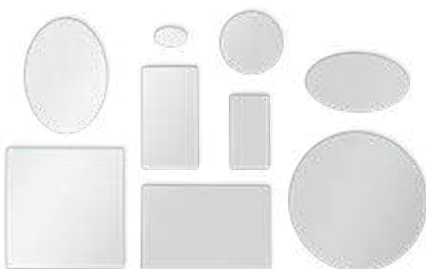

Assorted Plastic Mirror AP4010

Set of 36 plastic mirrors in assorted shapes and size.

- size: 8–11 cm

ACCESSORIES



Coloured pot with a handle JN0015

Plastic pot which helps to keep order. It can be used as a box on the shelf, on the rack or in the drawer. Delivered with a description label for the content.

- 1 pc;
- dim.: 11,8 x 10,5 x 7,6 cm;
- material: plastic



Connecting pots AP2533

Practical pots for storing art and writing supplies. They can also serve as water cups while painting with paints or they can be used to as an organiser for crayons or felt tip pens when combined. These containers make it easier to keep order and they don't take up too much space.

- 8 pots: yellow, orange, red, blue, purple, green, white, black;
- dim.: 11 x 10 cm;
- material: plastic; age: 3+

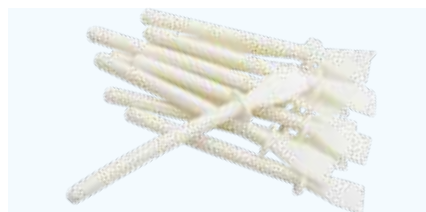

Glue spatulas AP0405

Glue spatulas suitable for every kind of glue. They are equipped with an elastic tip which makes using the spatulas easier. This product helps to keep the working space clean.

- set of 12 spatulas;
- material: durable plastic; length: 11,3 cm



Craft trays JN0094

Colourful rectangle trays for sorting counting stick or other small objects. They are equipped with comfortable handles. Raised sides of the trays prevent the contents from falling off the tray.

- 4 pcs; dim.: 38,5 x 2 x 28,5 cm;
- colour: green, red, yellow, blue;
- material: plastic

THEATRE CORNERS



Theatre
NS0223

- size: 87 x 1,8 cm



Puppet theatre
NS0580

Top and bottom curtains fit multipurpose stand NS0578 (sold separately).



Puppet theatre
OS7332

A light and easy-to-assemble puppet theatre for the young ones to try the role of a puppeteer. The elements can be fitted together without any tools, thanks to its size the theatre can be installed at any place and two children can play at the same time. For the theatre we recommend our hand puppet sets.

- 29 elements materials: plastic, fabrics;
- size after assembly: 68 x 1,0 cm;
- age: 3+



Colourful theatre
NS1955

- size: 87 x 1,8 cm



Multipurpose stand
NS0578

- serves as a play corner; with accessories can be used as a puppet theatre (NS0580), Glas painting corner (NS0581) or marketstall (NS0579)
- size: 84 x 51 x 113,5 cm



Market stall roof
NS0579

- red fabric; fits multipurpose stand NS0578



**Multi purpose shop center
NS0263**

A multi-purpose desk with counters for playing e.g. shop, post office or bank.

- made of MDF and laminated chipboard (birchwood)
- size: 100 x 50 x 1,0 cm



PUPPETS



Educational puppets Emotions NS2035

- 6 pcs, size: 25 x 22 cm;
- they teach young children to recognize and express emotions;
- six facial expressions help develop empathy;
- to complement: Balls – Emotions (LG0613)

Emotional puppets NS2034

Through operating hand puppets and staging plays children get to know the world of emotions, which helps them to understand other people's emotions. Expressing one's own emotions with the

help of hand puppets helps overcome shyness and communication barriers. All the puppets are made of soft fabric with plush elements and they sit firmly on small hands.

- happy, sad, frightened, angry, neutral, surprised;
- 6 pcs, H 25 cm



Family. Hand puppets OS7247

A hand puppet is an excellent therapeutic aid and useful in working with children. Easy to use, it brings fun and excitement of role playing.

It attracts the child's attention and prolongs concentration. Playing with hand puppets helps establish relations, develops self-expression and inspires confidence in withdrawn children.

- 6 pcs; H ca. 25 cm; age 3+



Family set NS2023

- 6 pcs;
- H 25 cm

BAG WITH HAND PUPPETS

Set of 14 soft colourful fairytale hand puppets in a handy foldout bag with handles and elastic bands to hold the puppets firmly in place and keep them tidy and ready to use. The puppets represent fairytale characters and animals: Little Red

Riding Hood, Grandma, Hunter, Wolf, knight, dragon, princess, fairy, elephant, bear, dog, frog, cow, cat.

- bag dim: 64 x 47 cm when folded;
- 64 x 94 cm when open



Bag with hand puppets 1 NS1966

- 14 puppets;
- 64 x 95 cm when opened



Bag with hand puppets 2 NS2036

- 14 puppets;
- 64 x 95 cm when opened



Fairy tales set NS1956

- 4 pcs;
- H 25 cm



Little Red Riding Hood set NS1961

- 4 pcs;
- H 25 cm



Royal Family set NS2027

- 5 pcs;
- H 25 cm



Animals set 1 NS1944

- 6 pcs;
- H 18 cm



Animals set 2 NS2033

- 5 pcs;
- H 18 cm





Children of the world NS2063

Two hand puppets featuring a woman and a man representing a given ethnic group:

- African, Arab, Chinese, Eskimo, Indian, Native American, European;
- made of felt with sew-on multicolour fabric decorations;
- 14 puppets, H 25 cm



Professions NS2062

A set of hand puppets representing typical professions: a hairdresser, cook, doctor, engineer, firefighter, gardener, lawyer, car mechanic, nurse, policeman, postman, soldier, teacher, pilot.

- made of felt with sew-on multicolour fabric decorations;
- 14 puppets, H 25 cm



FINGER PUPPETS 10 CM

Hand puppets made of coloured felt and easy to put on little fingers. A child can operate several puppets simultaneously and act the play by themselves or with friends.

- 7 pcs, 7 x 10 cm;
- made of felt

Shoemaker set Dragon NS1915

The set features Dratewka the shoemaker, Princess, King, Prince, Dragon, Knight, Sheep.



Little Red Riding Hood set NS1914

The set features Little Red Riding Hood, Mom, Wolf, Granny, Hunter



Bag with finger puppets NS1916

Set of 12 hand puppets in a handy house-shaped bag with a handle for carrying it or hanging it. The house and the puppets are made of

coloured felt. A child can operate several puppets simultaneously and act the play of the Wawel Dragon and The Little Red Riding Hood - by themselves or with friends. The set consist of a bag and puppets representing: Dratewka the

shoemaker, King, Princess, Prince, Dragon, Knight, Sheep, Little Red Riding Hood, Grandma, Hunter, Wolf, Mother.

- made of felt; 12 pcs;
- bag size: closed 35 x 30 x 4 cm, opened 60 x 30 cm

HAND & FINGER PUPPETS

The bunch of colourful fairy-tale characters in the form of hand puppets will take a young puppeteer into the world of fantasy to impersonate a favourite character or prepare a play at school or at home. The puppets develop imagination, creativity, self-expression, listening and manual skills. They also help overcome shyness and anxiety, and generally manage emotions. They provide an excellent opportunity to

play with parents and to build bonds while performing various social roles. The puppets have been divided thematically into fairy-tale characters and the most popular professions (policeman, cook, firefighter). All the puppets have plastic heads and the other elements are made of velour, fleece or satin. Thanks to the small size and weight they can be used even by the youngest and carried practically everywhere.



Bambi OS7324

6 hand puppets:

- owl, deer, fox, donkey, skunk, raccoon;
- H 22 cm, W 22 cm



Snow White OS7603

11 hand puppets

- 7 dwarfs, Snow White, Prince, Queen, Witch;
- H 30 cm, W 27 cm





Professions

OS7249

6 hand puppets:

- policeman, fireman, doctor, nurse, chef, pilot;
- H 26 cm W 24 cm



Story of Jesus Birth

OS7248

9 hand puppets:

- Joseph, Mary, Jesus, Three Kings, Shepherd, Goat, Angel;
- H 28 cm, W 24 cm;
- the smallest figure H 12 cm, W 10 cm



Little Red Riding Hood, Three Little Pigs, Pinocchio. Finger puppet

OS7314

11 finger puppets from 3 fairy tales

- Three Pigs, Wolf, Fairy Godmother, Pinocchio, Gepetto, Fox, Hunter, Little Red Riding Hood, Grandmother;
- H 14 cm, W 10 cm



Alice in Wonderland

OS7323

6 hand puppets:

- Alice, the Hatter, the White Rabbit, the Queen of Hearts, the Knave of Hearts, the Caterpillar;
- H 23 cm, W 22 cm

CAPS



Felt cap Elephant
KK7906

Felt cap Elephant in grey. It is decorated with characteristic features of an elephant and googly eyes. This cap is put on the head with the help of an elastic band. Universal size.



Dog mask
KK0270

• universal size; material: felt in black and two shades of brown; age: 6+



Red tiara
KK0485

• universal size, material: plastic, red rhinestones, red fluff; age: 6+



Felt cap Lion
KK1790

It is decorated with the characteristic features of the Jungle King.

• universal size, fits both children and adults; material: plastic, flexible wire, yellow and black felt; age: 6+



Wizard hat
KK1034

• 1 pc; universal size; material: fabric; age: 3+



King's crown
KK6770

• 1 pc; Universal size; material: synthetic fabric; age: 3+



Felt cap Hippo
KK0044

• 1 pc; universal size; elastic band which is to be put under the chin; material: felt; age: 3+



Queen's crown
KK6771

• 1 pc; Universal size; material: synthetic fabric; age: 3+



Felt cap Monkey
KK7904

Cap Monkey in brown. It is decorated with the characteristic features of a monkey. Googly eyes and ears.



Felt cap Ant
KK7910

Felt cap Ant with antenna in brown. It is decorated with characteristic features of an ant. This cap is put on the head with the help of an elastic band.



Felt cap Tiger
KK7911

Cap made of profiled felt in the shape of a Tiger. This cap is put on the head with the help of an elastic band.

- universal size; circ.: 50-55 cm



Felt cap Chicken Cap
KK7916

- universal size;
- material: plastic, white, red and yellow felt;
- age: 6+



Felt cap Chickling
KK7918

The cap Chickling will be perfect for a school performance or a ball in the theme of animals.

- circ.: 55 cm



Felt cap Squirrel
KK7923

It is perfect for shows, performances, animations, carnival games, themed games and more. It also fits both children and adults. This cap has an elastic band thanks to which it stays on the head.



Felt cap Sparrow
KK7924

Felt cap Sparrow. It is decorated with characteristic features of a sparrow. This cap has an elastic band thanks to which it stays on the head.



Felt cap Deer, Reindeer cap
KK7925

- universal size;
- material: plastic, felt in two shades of brown;
- age: 6+



Felt cap Carrot cap
KK7935

- universal size;
- material: plastic, orange and black felt;
- circ.: aprox. 55 cm age: 6+



Felt cap Buck
KK7927

Cap Buck. Perfect addition to the child's costume.

- universal size



Felt cap Donkey
KK7929

Cap Donkey. Perfect addition to the child's costume for the nativity play.

- universal size



Soft knight's helmet
KK0110

- universal size;
- material: grey and yellow felt;
- age: 6+



Felt cap Rooster
KK7933

Felt cap Rooster in white. It is decorated with characteristic features of a rooster. This cap has an elastic band thanks to which it stays on the head. An important element of the costume for school plays, kindergarten and other performances.

COSTUMES

- fabric: cotton with felted elements
- costumes are sold without puttets



Angel Halo
KK0120



Angel Wings
KK0403

- universal size, 55 x 48 cm



Frog cap and gloves
KK0080

The set consist of a cap made of velour-like fabric with sewn-in elastic band and covers for hands.



Little Red Riding Hood
OS7273

- dress & hooded cape, made of felt;
- height 80-110 cm, age: 3+



Policeman
OS7285

- shirt, trousers, cap; made of felt;
- fits height 80 - 110 cm; age: 3+



Robin Hood
OS7286

- shirt, trousers, cap; made of felt;
- fits height 80 - 110 cm; age: 3+



Granny
OS7274

- dress & bonnet, made of felt;
- height 80 - 110 cm, age 3+



Hunter
OS7275

- trousers, waistcoat, hat, made of felt;
- height 80 - 110 cm, age: 3+



Wolf
OS7276

- tunic, cap, gloves, made of felt;
- fits height 80 - 110 cm, age: 3+



Dragon
OS7289

- tunic, cap, gloves, made of felt;
- fits height 80 - 110 cm, age: 3+



Grizzly bear cap
KK6870

A cap made of nice to touch fabric with sewn-in elastic band.



Bee. Set
KK1905

- headband and wings



Vegetables headbands
KK0001

- universal size; 8 vegetables



Pig. Cap and tail
KK0005



Sheep
KK0006



Red flower cap
KK0688B



Rabbit
KK0681



Cow
KK0682



Owl
KK0685



Stork
KK0686



Cat
KK0786

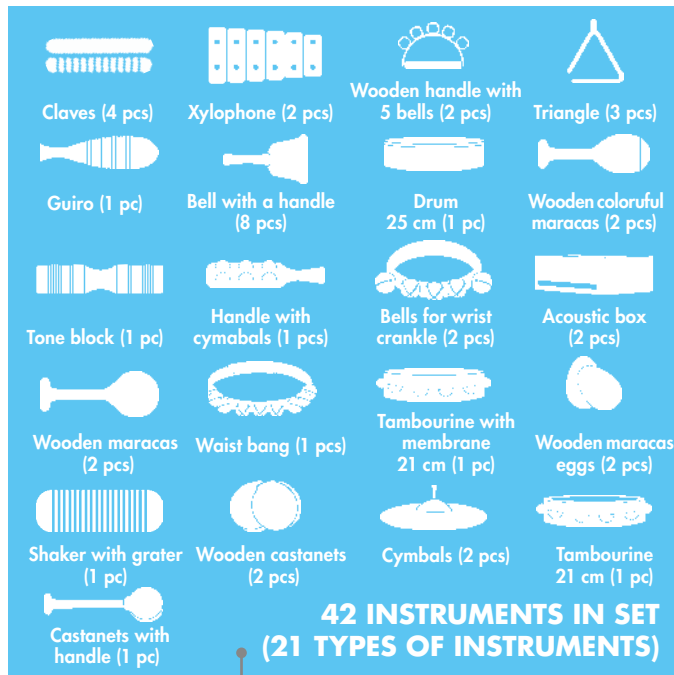

**Music trolley
PG9015**

Intended for children's instruments.

- dim.: 90 x 55 x 40 cm; only furniture

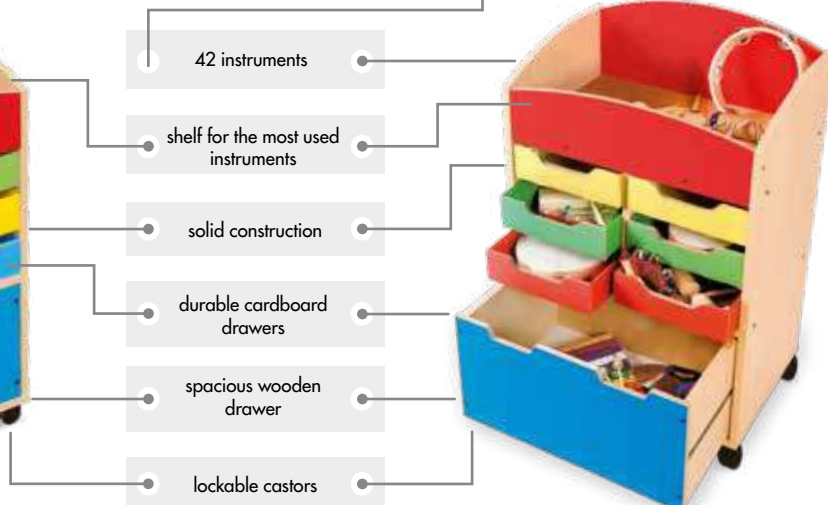

**Music trolley with instruments
PG9016**

Intended for children's instruments.

- dim.: 90 x 55 x 40 cm



Musical bag VO8319

A practical bag with many pockets, made from durable fabric and with a zipper. When opened it can be hung.

- dim (when closed): 40 x 40 cm
- weight 3,5 kg

Contents:

- tambourine
- tambourine with membrane
- 5 triangles (10 - 20 cm) with beaters
- 2 wooden maracas
- large guiro with beater
- 2 tone blocks (2 tones) with beaters
- 1 tone block (1 tone)
- wood block
- 2 castanets
- castanets with handle
- pair of claves
- metal shaker





Small musical set

NT0214

- 14 elements; size: 24 x 8 x 26 cm

Contents:

- drum with bells and membrane (ø 21 cm);
- 2 wooden maracas (L 15,2 cm);
- triangle (D 10 cm) with beater;
- wooden handle with 5 bells (10,5 x 8,5 cm);
- 2 castanets (D 5,8 cm);
- cymbal (ø 6 cm) with wooden stick;
- guiro (L 20,5 cm) with beater;
- pair of claves



Small musical bag

NT1821

A set of musical instruments in zipped plastic bag with a handle. 9 element in total.

Contents:

- bag size: 23 x 7 x 21 cm;
- a wooden drum (D 15 cm);
- bells (L 22 cm);
- 2 plastic maracas (H 18 cm);
- triangle (H 10 cm) with beater (L 16 cm);
- 2 wooden drumsticks (L 20 cm);
- cymbals with wooden handles (L 25 cm)



Small bag with music instruments

NT0149

Musical set of 5 instruments. It helps to develop musical abilities and motor skills.

- age: 1+



Toucan. Music kit

CI4032

This set for beginning musicians contains: xylophone, tambourine, castanets. It is a great aid in developing sensitivity, hearing and sense of rhythm. Thanks to it children can learn to recognise various sounds. All instruments are suitable for young users.

- 7 pcs:
 - 1 x xylophone, 1 x flute, 1 x tambourine, 2 x castanets, 2 x drumsticks;
- material: wood, metal;
- dim. of the packaging: 40 x 6,5 x 30 cm;
- age: 18 months +

WOODEN INSTRUMENTS



Small Guiro grater
NT1021

- size: 21 x 5,8 x 5,8 cm



Triple agogo
NT9005

- H 26 cm, ø 4 cm



Shaker with grater
PG0735

- size: 4 x 15 cm, 1 pc



Guiro
PG1715

- size: 20,5 x 4,2 x 4,2 cm



Cabasca
NT9804

- ø 11 cm



Acoustic box
PG4618

- size: 16,5 x 5,5 x 3,8 cm



Tone block
VO5276

- size: 18 x 4 x 18 cm



Castanets with handle
PG1722

- size: 21,3 x 5,5 x 2,7 cm



Wooden maracas
NT0100

- 2 pcs, size: 15,2 x 5,3 x 5,3 cm



Wooden colourful maracas
NT0404

- 2 pcs, size: 20,5 x 6 x 6 cm



Wooden maracas Eggs
NT2201

- 2 pcs;
- size: 8,4 x 4,5 x 4,5 cm



Big and colourful rumba shakers.
Classroom kit
NT2111

Set of simple colourful rumba shakers. The product is made of safe and BPA-free material, lead and phthalates.

- 12 pcs, in 6 colours: 2 x white, 2 x yellow, 2 x red, 2 x green, 2 x blue, 2 x purple; dim.:
- diam.: 4,5 cm, height: 6,5 cm; material: plastic; age: 0+



Castanets
VO4155

- 2 pcs, size: 5,8 x 5,8 x 1,6 cm; wooden



Castanets
NT9303

- size: 5,8 x 5,8 x 1,6 cm, 2 pcs; made of plastic



Rain maker
NT1032

- size: 24 x 4,5 x 4,5 cm

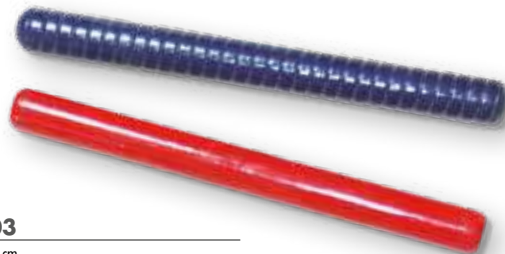

Claves
NT9603

- 2 pcs, 20 cm



Tambourine with a membrane
PG7701

- ø 27 cm



Drum with bells and a membrane
NT2401

- 5 bells, ø 21 cm



Tambourine
PG1771

- ø 21 cm



Drum on belt
NT3301

- ø 20 cm



Wooden drum
NT3305

- size: 20 x 20 x 10 cm



Big drum
VO4181

- ø 25 cm



Small drum
OV0335

- ø 21 cm



Wooden stick
PG3713

- L 17 cm



Kalimba green 8 tone
NT6140

8 Key Green Pine kalimba finger thumb piano. Easy to play, just need to use two thumbs play to make a sound. Presented with a portable bag for easy carrying and storage and a musical spectrum.

- size: 17 x 13 x 3,5 cm



Bongos
VO4956

- ø 15 cm, H 19 cm



INSTRUMENTS



Flower tambourine
VO5762

- size: 21,5cm; 16 pairs of round cymbals



Tambourine
NT7081

- 2 pcs, size: 14 x 11,5 x 2,5 cm

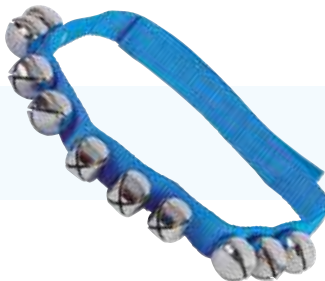

Waist bang
NT3304

- size: 78 x 2,5 x 3 cm; 10 bells



Wooden handle with 5 bells
NT4200

- size: 10,5 x 8,5 x 2,5 cm



Handle with cymbals
NT8300

- size: 22,5 x 5 x 3,5 cm



Bells for wrist or ankle
PG7550

- size: 23 x 2,3 x 3 cm; 2 pcs



Ocean drum
NT1001

Close your eyes and sway the drum slowly, you will hear the sound of an ocean.

- 1 pc; size: 25 x 25 x 3,5 cm



Triangle
PG1733

- size: 10 x 10 x 0,7 cm



Cymbals
PG7852

- size: 15 x 15 x 1,8 cm



Cymbal with wooden stick
PG1788

- ø 6 cm



2-in-1 pound & tap bench
CI3515

This 2-in-1 toy helps tune your child's ear to the different sounds they can make. Put the ball in the hole, tap it and listen to the chime. Or turn it over and just use the hammer to make music!

- size: 29 x 18,5 x 10 cm; age: 1+



8 tone colored resonator bells
NT5920

8 single bells in different colours for different notes of the scale.



Rainbow wooden xylophone
NT9302

- size: 33 x 22 x 4 cm
- 2 wooden mallets
- age: 3+



Metal bells
NT9701

- size: 42 x 14,5 x 4,5 cm
- resonance box



8-ton bells
NT9214

- 8 tones; 2 sticks; material: pinewood, metal, plastic;
- age: 3+



Metal bells
PG1800

- 12 tone metalophone; size: 33 x 12 cm



Metal bells
PG1801

- 27 tone metalophone
- size: 42 x 24 cm



Piano horn
NT5520

- size: 43 x 8 x 5 cm



Ukulele
NT0001

A wooden toy instrument. The soundbox with 4 vinyl strings tuned with pegheads.

- size: 53 x 5,5 x 17 cm



Acoustic cubes
BE1009

- 8 pairs of boxes with different tones



Music box
NS0427

- base size: 29 x 15,5 x 2,3 cm
- each box: 6,7 x 6,7 x 4,7 cm



**Accordion
NT5830**

A toy instrument with hand-operated bellows.
Keyboard - one and a half octave range, 8 buttons.
• size: 47 x 22 x 10 cm



**Sound balls with notes of music
NT3500**

Sound-making rubber balls with musical notes.
• 8 pcs, dim.: 6,1 x 6,1 x 6,1 cm

FLUTES



Professional wooden flute
NT5600

A professional flute with a cleaning brush.

- length 32 cm



Classical flute
OV0100

size: 32 x 3 x 3 cm



Kazoo
PG7510

- L 12 cm, 5 pcs

BELLS



The worksheets not only make the work of music teachers much easier but also allow children to be independent. All carols are shown in the form of colours, numbers, pictures, and notes. The songs for bells and a flute are identical and they have the same designations which allows the teacher to present them together.

- 24 pcs, dim.: 11 x 23 cm



Popular melodies
NS4203

Worksheets with popular and easy-to-play melodies. Each song with three notations: solmization, musical and colour/numeric.

- 24 sheets; size: 11 x 23 cm



Christmas carols
NS4204

Worksheets with popular and easy-to-play Christmas Carols. Each Carol with three notations: solmization, musical and colour/numeric.

- 24 sheets; size: 11 x 23 cm



Playing bells or a flute can be really easy. These worksheets will help children who can't read music notes to play with the use of colours, numbers, and pictures. Even the youngest children will be able to join the fun and the satisfaction from playing a song on their own will encourage them to continue their adventure with music.



Bells with a button

VO8528

- 8 ringtones: diatonic, F# and B



Bells with a handle

VO8535

- 8 bells



Rotating wheel with bells

NT0604

Colourful 8-tone bells made of metal on a rotating wheel. Each sound has a specific colour assigned to it.

- 8 tones;
- 1 stick;
- material: metal, plastic;
- age: 3+



TOYS

CABINET FOR BRICKS



over 1200 pieces



8 types
of building blocks



8 sets
of worksheets

ECO. Storage cabinet with bricks and worksheets NS4000

- 8 large cardboard containers;
- 8 types of building blocks, over 1200 pieces;
- 8 sets of worksheets;
- cabinet made of chipboard laminated in birch colour size: 56 x 38 x 94 cm;
- over 1200 pieces



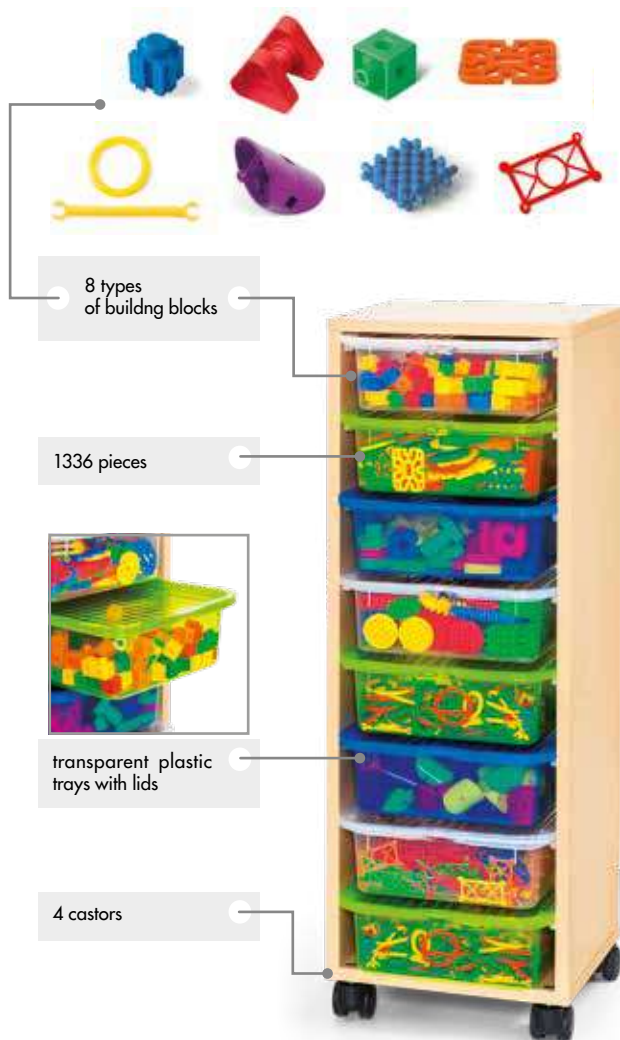

Mobile Storage unit with plastic containers and bricks NS4444

A mobile storage unit with 4 castors (2 with locks).

- 8 plastic containers with lids;
- 8 sets of bricks, 1336 pieces;
- cabinet size: 34 x 34 x 97 cm;
- containers in random colours (blue, green or white);
- all bricks come with worksheets which are available separately



Worksheets for building blocks NS4445

- set of worksheets for 7 types of building blocks;
- 168 cards;
- 3 sets of instructions for Morphun Junior Starter blocks;
- worksheets size: 11,5 x 11,5 cm



Maxi mobile cabinet with bricks and plastic containers NS4446

Mobile maxi cabinet made of birch-coloured laminated board. Transparent containers included in the set make maintaining order and hygienic storage of toys in kindergartens and school common rooms much easier. Rich selection of various types of bricks placed in separate containers is also included. It is suitable for group or individual work. Plastic wheels with a lock allow the user to quickly and easily move the furniture to the center of the room or to another place.

- dim.: 65,6 x 34,3 x 97,1 cm;
- 16 sets of bricks, 2041 pieces;
- material: birch-coloured laminated board, 18 mm thick, white furniture board, 12 mm thick;
- 16 transparent containers with plastic lids with dim. 37 x 10 x 30 cm in green, blue, colorless;
- bricks sets: NS4004 Sprockets, NS4079 Connecting building blocks, NS4112 Basic blocks with printing, NS4105 Arrows, NS4100 Klik bricks, NS4208 Tower bricks, NS4098 Cubes, NS4104 Hedgehogs mobile, NS4096 Hexi, NS4016 Wraps, NS4005 People Acrobats, NS4007 Modules, NS4013 Windows, VO0786 Magnetic bricks, NS4301 Neopuzzle. Full figures and windows, NS4106 Molecules.



Set of worksheets for mobile maxi cabinet NS4447

- 384 pcs: 24 worksheets in each set;
- worksheet size: 11,5 x 11,5 cm;
- every set is in cardboard packaging



Bricks sets included:

NS4004



NS4096



NS4079



NS4016



NS4112



NS4005



NS4105



NS4007



NS4100



NS4013



NS4208



VO0786



NS4098



NS4301



NS4104



NS4106



BRICKS WITH WORKSHEETS

The idea behind the chore charts was to give variety to games and plays through extension with new variants. These are created in co-operation with teachers, who have practical knowledge of the school and preschool environments. The charts may facilitate teacher-run activities but also lend themselves to individual play at home.

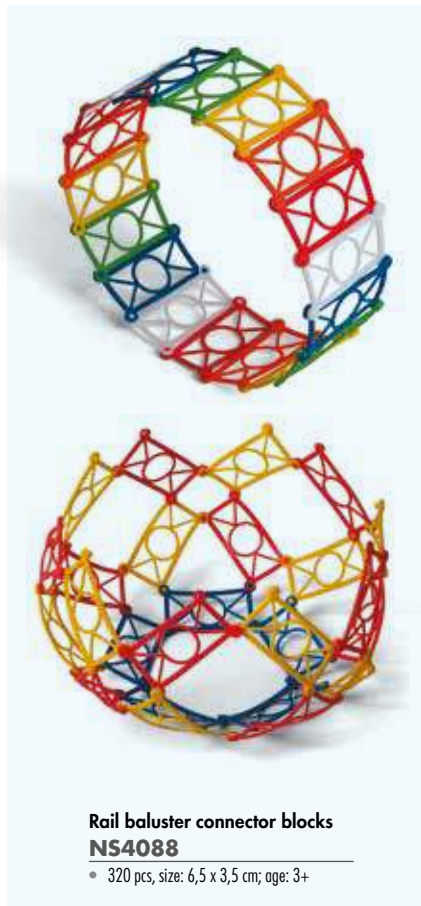
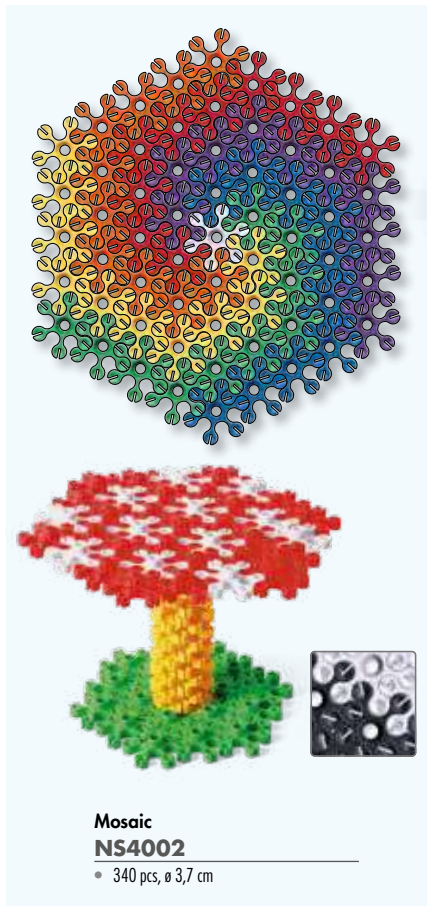

Worksheets for NS4002
NS4002W

- 24 pcs; size: 11,5 x 11,5 cm



Worksheets for NS4088
NS4088W

- 24 pcs; size: 11,5 x 11,5 cm



Worksheets for NS4016
NS4016W

- 24 pcs; size: 11,5 x 11,5 cm



Machanic
NS4006

• 64 pcs

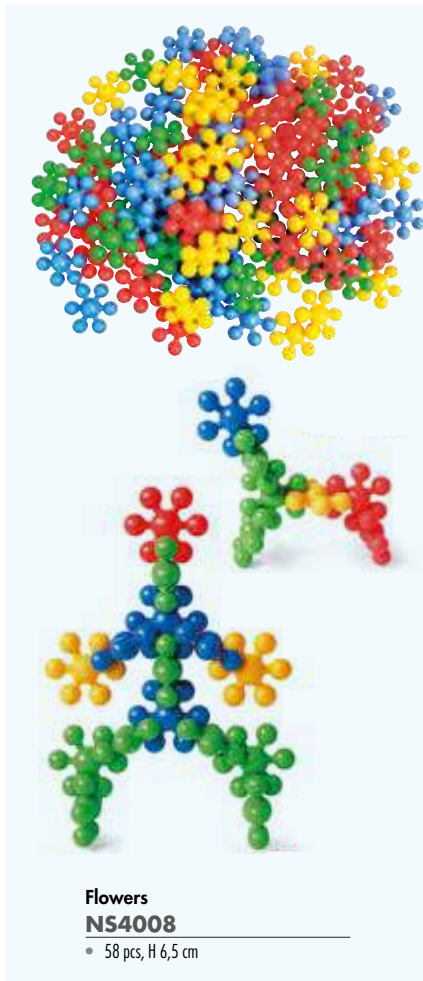

Flowers
NS4008

• 58 pcs, H 6,5 cm



Windows
NS4013

• 100 pcs, side 2 cm



Worksheets for NS4006
NS4006W

• 24 pcs; size: 11,5 x 11,5 cm



Worksheets for NS4008
NS4008W

• 24 pcs; size: 11,5 x 11,5 cm



Worksheets for NS4013
NS4013W

• 24 pcs; size: 11,5 x 11,5 cm

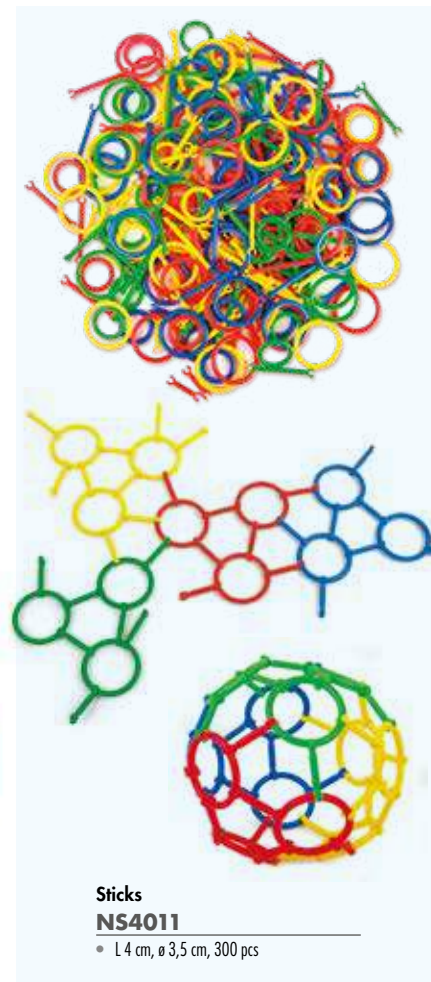
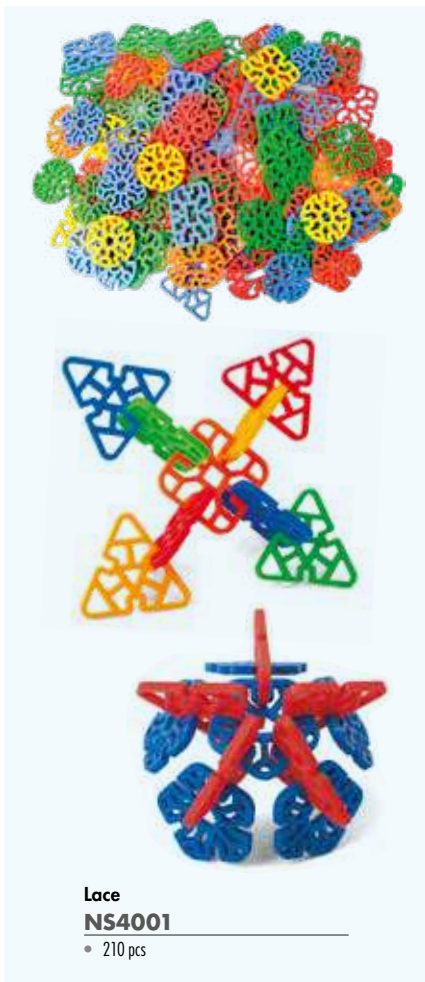

Worksheets for NS4001
NS4001W

- 24 pcs; size: 11,5 x 11,5 cm



Worksheets for NS4007
NS4007W

- 24 pcs; size: 11,5 x 11,5 cm



Worksheets for NS4011
NS4011W

- 24 pcs; size: 11,5 x 11,5 cm



Tubes 1
NS4003

- 80 pcs, ø 2,8 cm



Sprockets
NS4004

- 80 pcs, ø 4,3 cm



Tubes 2
NS4091

- 80 pcs, ø 2,8 cm



Worksheets for NS4003
NS4103W

- 24 pcs; size: 11,5 x 11,5 cm



Worksheets for NS4004
NS4004W

- 24 pcs; size: 11,5 x 11,5 cm



Worksheets for NS4091
NS4003W

- 24 pcs; size: 11,5 x 11,5 cm

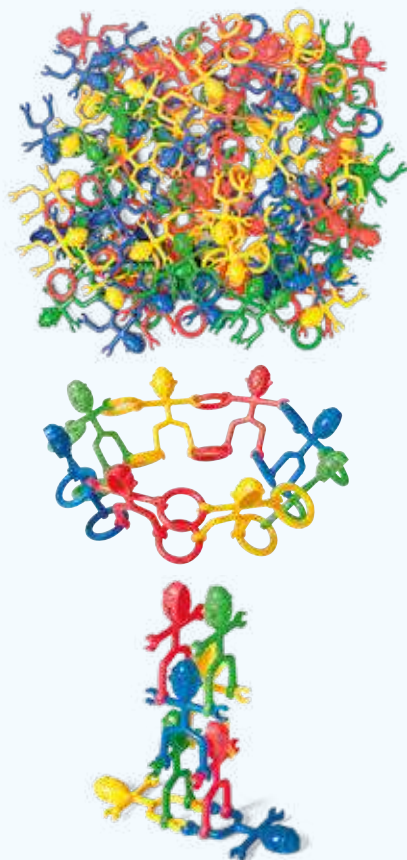

People Acrobats
NS4005

- 144 pcs, H 9 cm

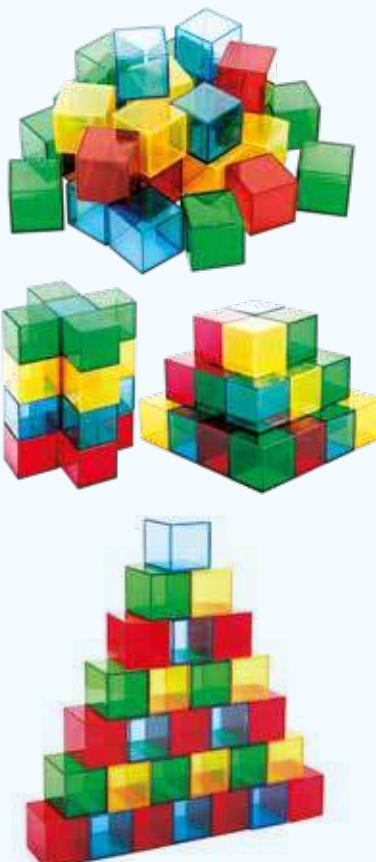

Cubes
NS4062

- 36 pcs, side 4 cm



Transparent cubes
NS4063

- cube side L 4 cm, 36 pcs



Worksheets for NS4005
NS4005W

- 24 pcs; size: 11,5 x 11,5 cm



Worksheets for NS4062
NS4062W

- 24 pcs; size: 11,5 x 11,5 cm



Worksheets for NS4063
NS4063W

- 24 pcs; size: 11,5 x 11,5 cm





**Suction cup
NS4093**

- 42 pcs

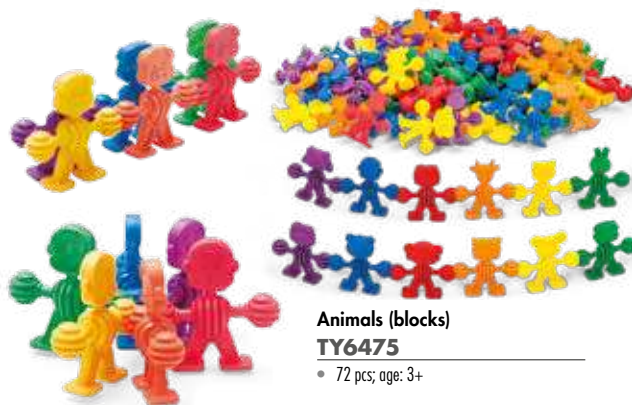

**Animals (blocks)
TY6475**

- 72 pcs; age: 3+



**Worksheets for NS4093
NS4093W**

- 24 pcs; size: 11,5 x 11,5 cm



**Worksheets for TY6475
TY6475W**

- 24 pcs; size: 11,5 x 11,5 cm



**Screws
VO5054**

- 32 screws and 32 nuts, 4 colours, 4 shapes
- screw H 6,5 cm

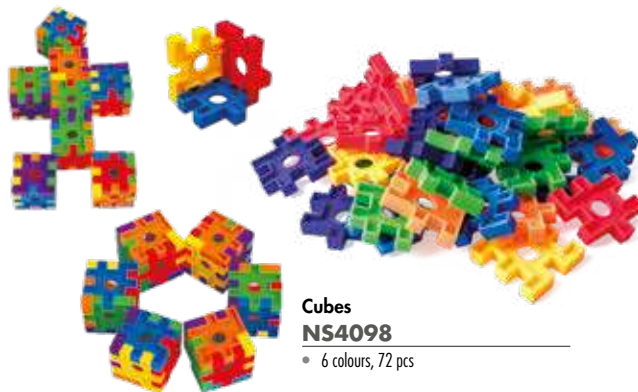

**Cubes
NS4098**

- 6 colours, 72 pcs



**Worksheets for NS5054
VO5054W**

- 24 pcs; size: 11,5 x 11,5 cm



**Worksheets for NS4098
NS4098W**

- 24 pcs; size: 11,5 x 11,5 cm)



Multicubes VO3583

- 100 pcs, cube side 2 cm



Transparent maths cubes JN0021

Cubes made of a durable semi-transparent plastic. Perfect for learning to count, sort and create patterns.

- dim.: 2 cm; age: 3+



Worksheets for transparent maths cubes JN0021W

- 24 pcs;
- dim.: 11,5 x 11,5 cm;
- varying levels of difficulty;
- cardboard box; age: 3+



Connectors for multi-blocks NS4095

Colourful connectors for VO3583 blocks for spatial games. By playing with the blocks children develop precision of movements, hand-eye coordination, and spatial sense. We recommend combining the blocks with dedicated VO3583 worksheets for more guided activities.

Product specifications:

- 100 elements, 3 different kinds in many colours: cubes, quarters, triangles;
- material: plastic; age: 3+



Worksheets 1 for VO3583 VO3583W

- 24 pcs; size: 11,5 x 11,5 cm



Worksheets 2 for VO3583 VO3584W

- 24 pcs; size: 11,5 x 23 cm



Worksheets for multibricks with connecting elements NS3585W

Set of 24 worksheets for multibricks with connecting elements (NS4095+VO3583).

- dim. of a single piece: 11,5 x 11,5 cm; the combination ideas vary in their level of difficulty; all worksheets can be easily stored thanks to the box included in the set; age: 3+



Elastic Mini Waffles
MA2141

- 500 pcs, 8 colours, 1 pc size: 3,5 x 3,5 cm



Bones
NS4094

- 160 pcs

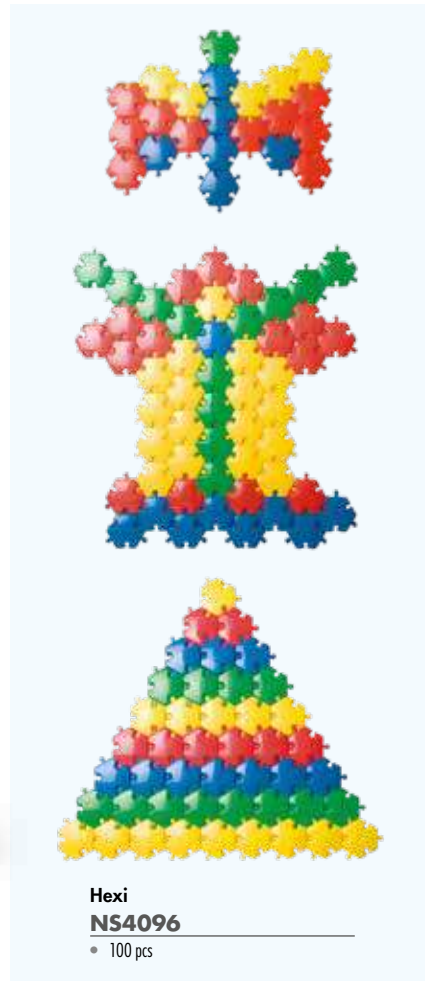

Hexi
NS4096

- 100 pcs



Worksheets for MA2141
MA2141W

- 24 pcs; size: 11,5 x 11,5 cm



Worksheets for NS4094
NS4094W

- 24 pcs; size: 11,5 x 11,5 cm



Worksheets for NS4096
NS4096W

- 24 pcs; size: 11,5 x 11,5 cm



Hedgehog bricks
NS4086

- 72 pcs; L 4 - 15 cm; age : 3+



Hedgehogs mobile
NS4104

- 200 pcs

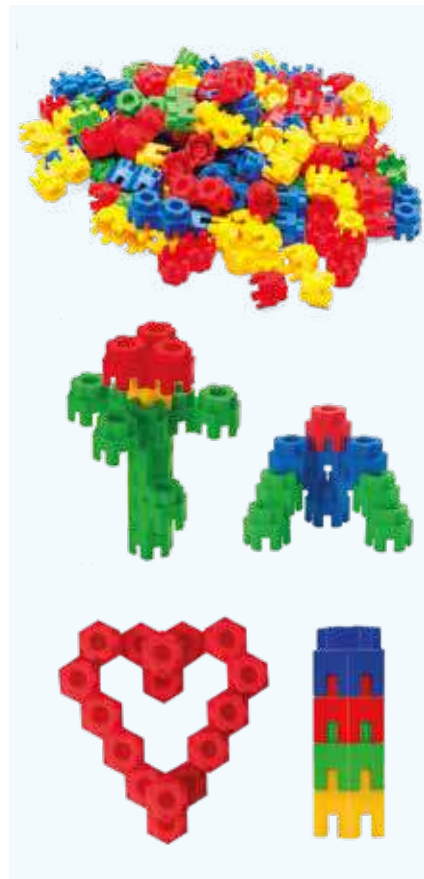

Tower bricks
NS4208

- 144 pcs



Worksheets for NS4086
NS4086W

- 24 pcs; size: 11,5 x 11,5 cm



Worksheets for NS4104
NS4104W

- 24 pcs; size: 11,5 x 11,5 cm



Worksheets for NS4208
NS4208W

- 24 pcs; size: 11,5 x 11,5 cm





Klik bricks
NS4100

- 5 colours, 60 pcs

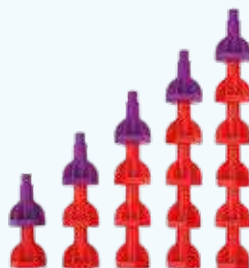

Arrows
NS4105

- 120 pcs



Molecules
NS4106

- 140 pcs



Worksheets for NS4100
NS4100W

- 24 pcs; size: 11,5 x 11,5 cm



Worksheets for NS4105
NS4105W

- 24 pcs; size: 11,5 x 11,5 cm



Worksheets for NS4106
NS4106W

- 24 pcs; size: 11,5 x 11,5 cm

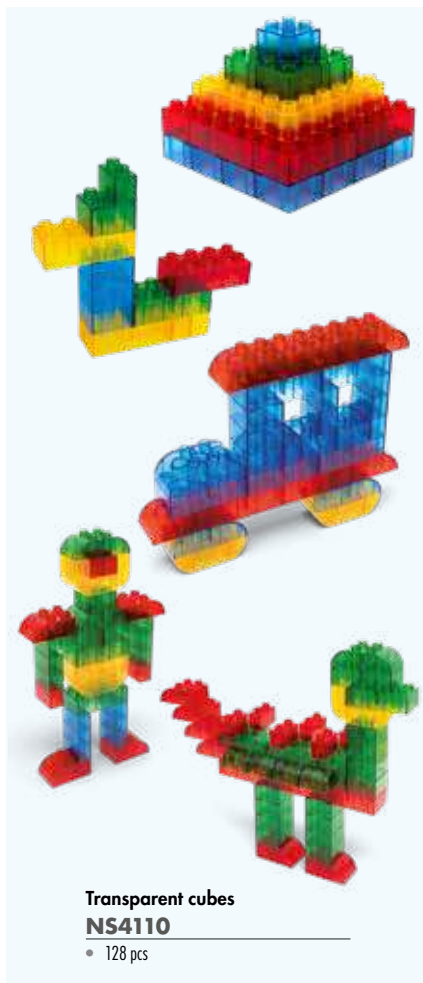

Worksheets for NS4109
NS4109W

• 24 pcs; size: 11,5 x 11,5 cm



Worksheets for NS4110
NS4110W

• 24 pcs; size: 11,5 x 11,5 cm



Worksheets for NS4111
NS4111W

• 24 pcs; size: 11,5 x 11,5 cm



Basic blocks with printing
NS4112

- 85 pcs



Connecting building blocks
NS4079

Educational building blocks of the same shape are great for building fantastic spatial structures. Connecting pieces is very easy and intuitive. By moving from easy to more difficult designs the child develops hand-eye coordination and improves the muscles of the hand and fingers.

- 280 elements in 6 colours
- piece size: 3,3 x 3,3 x 1,2 cm



Building blocks with minifigures
NS4078

Coloured building blocks allow the youngest to develop hand-eye coordination, distinguish colours and match them according to a pattern provided. With this set children can create colourful figures which can become characters in stories and help develop linguistic skills.

- 52 elements in 5 colours; age: 3+



Worksheets for NS4112
NS4112W

- 24 pcs; size: 11,5 x 11,5 cm



Worksheet for construction bricks – crown
NS4079W

- 24 pcs; meas. 11,5 x 11,5 cm; different level of difficulty;
- cardboard box; age: 3+



Worksheet for building blocks with minifigures
NS4078W

- 24 pcs; 11,5 x 11,5 cm; different level of difficulty;
- cardboard box; age: 3+



Rounded transparent bricks JN0040

Colourful bricks shaped in a way that allows children to construct letters and numbers. Simple connections in the form of press studs, together with attached worksheets, enable the creation of flat

constructions. Bricks can be used for games and experiments with colours and shapes on the light panel.

- 180 pcs: meas. of the biggest element: 10 cm;
- 27 worksheets;
- material: plastic;
- packaging: plastic bag; age: 3+



Worksheets for rounded transparent bricks JN0040W

Set of 24 worksheets for rounded transparent bricks with connecting elements (JN0040W).

- dim. of a single piece: 11,5 x 11,5 cm;
- the combination ideas vary in their level of difficulty;
- all worksheets can be easily stored thanks to the box included in the set;
- age: 3+



Transparent bricks for building geometric solids. Windows JN0048

Set of bricks with windows. Their structure allows the user to create spatial constructions. Simple connection of elements ensures many hours of creative fun. They teach logical thinking, recognizing shapes and colours,

handling objects and matching them together. These brick also work perfectly with the light panel.

- 120 pcs in different shapes: triangle, rectangle, square;
- 10,5 x 7,4 cm;
- material: plastic;
- packaging: plastic bag;
- age: 3+



Worksheets for transparent windows for creating geometric solids JN0048W

Set of 24 worksheets for transparent bricks for Creating geometric solids - windows (JN0048W).

- dim. of a single piece: 11,5 x 11,5 cm;
- the combination ideas vary in their level of difficulty;
- all worksheets can be easily stored thanks to the box included in the set;
- age: 3+





Transparent nails with board JN0110

Creative toy, which not only provides a lot of fun, but also helps to stimulate the child's development. The set includes a board with many holes in which the children can put colourful elements to create patterns and images. This toy stimulates creativity and trains hand-eye coordination.

- 101 pcs: 100 nails; diameter: 2,5 cm, H 3 cm;
- colours: yellow, orange, red, green, blue, purple;
- 1 transparent base,
- 20 x 20 cm;
- material: plastic;
- packaging: plastic bag;
- age: 3+



Worksheets for transparent nails with a board JN0110W

- set of 24 worksheets for transparent nails with a board (JN0110W); dim. of a single piece: 11,5 x 11,5 cm; the combination ideas vary in their level of difficulty; all worksheets can be easily stored thanks to the box included in the set; age: 3+



Transparent bricks with board JN0111

Colourful bricks for creating various constructions. They improve the child's imagination and manual abilities. The set includes a transparent board for attaching construction elements, which makes building, and later transporting the end results, much easier. Semi-transparent brick creations can be placed on the light panel.

- 101 pcs: 1 transparent board: 20 x 20 cm, 100 bricks in 6 colours: yellow, orange, red, green, blue, purple;
- meas. of the brick: 2 x 2,2 x 2 cm;
- material: plastic;
- packaging: plastic bag;
- age: 3+



Worksheets for transparent bricks with a board JN0111W

- set of 24 worksheets for transparent bricks with a board (JN0111); dim. of a single piece: 11,5 x 11,5 cm; the combination ideas vary in their level of difficulty; all worksheets can be easily stored thanks to the box included in the set; age: 3+



Transparent tubes. Constructions bricks JN0036

Transparent tubes in different shapes allow children to create simple patterns or complicated three-dimensional constructions. A simple system of connecting elements makes possible building figures, labyrinths, scaffoldings and many other structures. These bricks stimulate imagination, encourages creative thinking and develops fine motor skills. The set, when combined with the light panel, will provide many spectacular visual sensations.

- 80 pcs: 32 straight tubes, 32 L-shaped tubes, 8 T-shaped tubes, 8 crosses; dim. of the straight tube: 7 x 2,2 cm;
- colour: yellow, green, red, orange, blue;
- material: plastic; packaging: plastic bag; age: 3+



Worksheets for transparent tubes JN0036W

- set of 24 worksheets for construction bricks — transparent tubes (JN0036W); dim. of a single piece: 11,5 x 11,5 cm; the combination ide as vary in their level of difficulty; all worksheets can be easily stored thanks to the box included in the set; age: 3+



Vehicles. Mobile construction bricks NS4101

Set of colourful bricks for constructing vehicles. It is based on a system of holes placed in the main elements, to which other parts can be screwed on or attached. The wheels included in the set allow cars to move on the floor. The activity with the bricks helps to develop spatial imagination, manual skills and eye-hand coordination. Through play, the child learns to use logical thinking, handle objects and match them.



Gears. Construction bricks NS4102

Creative set which combines fun and learning. Different types of bricks, including gears, allow children to build vehicles and mechanisms which can be set in motion. Play time with bricks helps to develop spatial imagination, manual skills and it teaches to use logical thinking. It also shows how gear wheels work and their use in mechanics.

- 88 pcs in different shapes and colours: red, yellow, blue, green;
- material: plastic; packaging: plastic bag; age: 3+



Caterpillar. Construction bricks NS4108

Set of bricks consisting of one type of element in different colours. Its design will stimulate children's imagination and creativity. These homogeneous bricks can inspire the creation of unusual spatial structures, animals and funny characters. Play time with the set has a positive effect on the child's development by improving motor skills, dexterity, and developing logical thinking skills.

- 80 pcs in red, yellow, blue, green, purple;
- material: plastic; packaging: plastic bag; age: 3+



Worksheets for Gears NS4102W

- set of 24 worksheets for construction bricks - gears (NS4102W), dim. of a single piece: 11,5 x 11,5 cm; the combination ideas vary in their level of difficulty; all worksheets can be easily stored thanks to the box included in the set; age: 3+



Worksheets for Vehicles NS4101W

- set of 24 worksheets for mobile construction bricks - vehicles (NS4101W), dim. of a single piece: 11,5 x 11,5 cm; the combination ideas vary in their level of difficulty; all worksheets can be easily stored thanks to the box included in the set; age: 3+



Worksheets for Caterpillar NS4108W

- set of 24 worksheets for construction bricks - caterpillar (NS4108W) dim. of a single piece: 11,5 x 11,5 cm; the combination ideas vary in their level of difficulty; all worksheets can be easily stored thanks to the box included in the set; age: 3+



MAGNETIC BRICKS



Magnetic bricks VO0786

- 244 pcs, magnets in the shape of balls ø 1,3 cm and rectangles 1,5 x 2,5 cm



Worksheets for magnetic blocks VO0786W

- 24 pcs 11,5 x 11,5 cm in a box



Neopuzzle. Full figures and windows NS4301

- 32 elements; full-figure blocks and blocks with windows
- smallest element 6 x 7 cm, biggest 15 x 15 cm



Worksheet for magnetic bricks – Neopuzzle NS4301W

- 24 pcs: 16 worksheets with spatial constructions, 8 worksheets with flat constructions;
- meas. 11,5 x 11,5 cm;
- different level of difficulty;
- cardboard box;
- age: 3 +

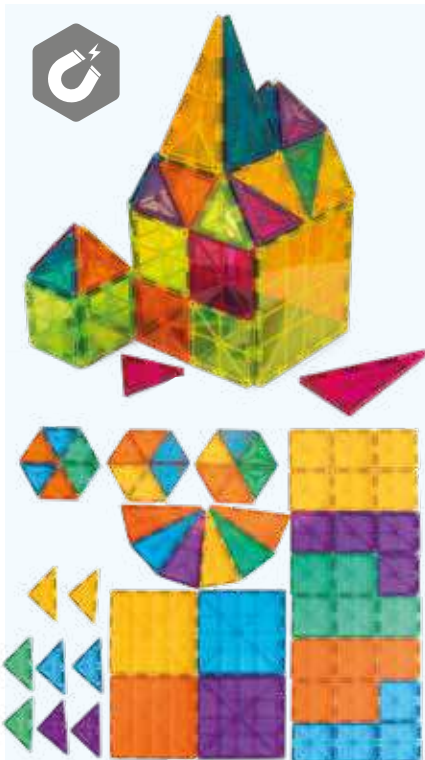

Neopuzzle. Full figures
NS4302

- 60 elements; full-figure blocks
- smallest element 6 x 7 cm, biggest 15 x 15 cm



Neopuzzle. Empty figures + chassis
NS4303

- 32 elements; empty-figure blocks
- smallest element 6 x 7 cm, biggest 11,2 x 12,7 cm, base 7 x 7 cm, circle D 5,8 cm



Worksheet for magnetic bricks.
Neopuzzle built-up figures
NS4302W

- 24 pcs; 16 worksheets with spatial constructions, 8 worksheets with flat constructions; meas. 11,5 x 11,5 cm; different level of difficulty; cardboard box; age: 3 +



Worksheet for magnetic bricks.
Neopuzzle figures with circles
NS4303W

- 24 pcs; meas. 11,5 x 11,5 cm; different level of difficulty; cardboard box; age: 3 +



Neopuzzle full shapes.
Magnetic bricks
NS4306

- 49 pcs;
- includes platforms with wheels for vehicle construction;
- material: plastic, magnet;
- age: 3+

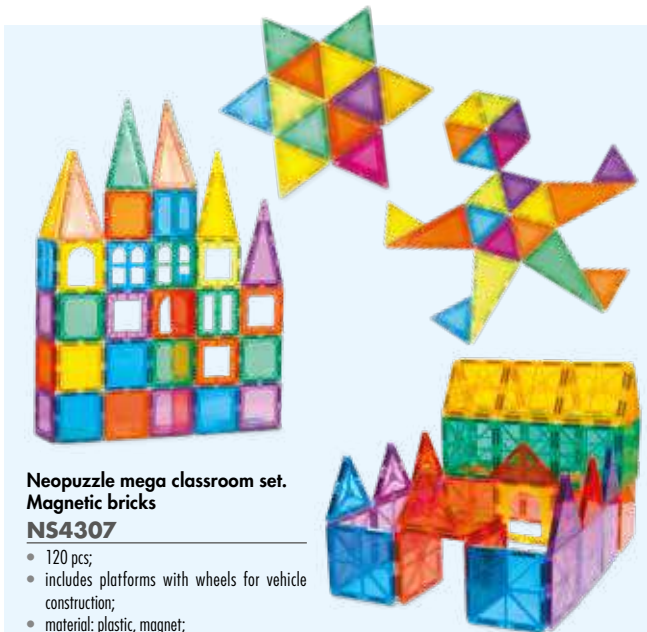

**Neopuzzle mega classroom set.
Magnetic bricks
NS4307**

- 120 pcs;
- includes platforms with wheels for vehicle construction;
- material: plastic, magnet;
- age: 3+

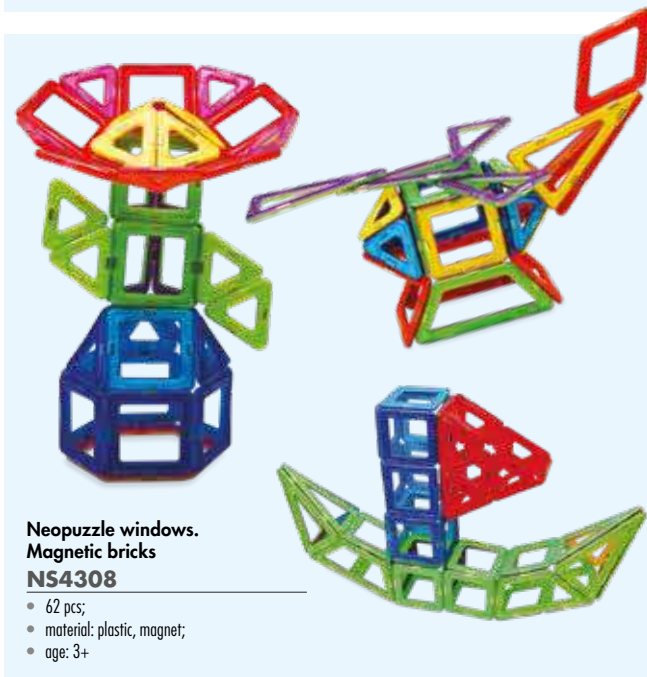

**Neopuzzle windows.
Magnetic bricks
NS4308**

- 62 pcs;
- material: plastic, magnet;
- age: 3+

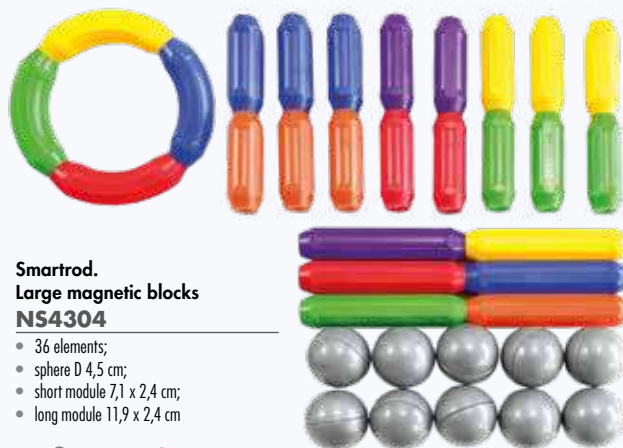

**Smartrod.
Large magnetic blocks
NS4304**

- 36 elements;
- sphere D 4,5 cm;
- short module 7,1 x 2,4 cm;
- long module 11,9 x 2,4 cm



**Worksheet for magnetic
bricks – Smartrod
NS4304W**

- 24 pcs; meas. 11,5 x 11,5 cm;
- different level of difficulty;
- cardboard box;
- age: 3+



Neopuzzle.
Empty figures
NS4305

- 36 elements;
- sphere D 4,5 cm;
- short module 7,1 x 2,4 cm,
- long module 11,9 x 2,4 cm



Worksheet for magnetic
bricks – Neopuzzle
simple figures
NS4305W

- 24 pcs: 16 worksheets with spatial constructions, 8 worksheets with flat constructions;
- meas. 11,5 x 11,5 cm;
- different level of difficulty;
- cardboard box;
- age: 3+



Magnetic cube with worksheets
UT0032

Transparent magnetic bricks which allow children to build various spatial constructions based on instruction with pictures or their own ideas. Combining the bricks is very simple thanks to the built-in magnets. Playtime with the set is not only fun, but it also promotes harmonious development of the child.

These bricks improve the ability to solve spatial problems, they also stimulate creativity and analytical skills. Additionally, the set develops motor skills and stimulates the senses.

- 7 pcs;
- in different configurations,
- dim.: cubes when folded: 6 x 6 x 6 cm;
- instruction; material: plastic, magnet;
- age: 3+

logicubes

ZEBRA

These printed wooden cubes are a complete educational set which develops logical and spatial thinking and thus it prepares children for elementary programming. The game comes in three versions, each meeting different needs and skills of the users. The complete set comprises cubes, reference charts, grid transparencies and self-evaluation charts, and their number depends on the level of difficulty. Simple rules, the simple structure of the set and the self-evaluation charts develop independent activity irrespective of age. All the cubes have the same number and pattern configurations. They are elements of one of 30 suggested jigsaws. We offer 3 sets of cubes (of 9, 16 or 25 pieces). The worksheets are numbered according to the level of difficulty. The cubes can be arranged freely on the table or on the tray provided. More demanding players will be interested in the 3D version (with worksheets and a tray).



Pyramid.
3D holder and worksheets
for Logi-cube Zebra

LA0320

- 3 trays 18,5 x 18,5 cm for building pyramids
- 12 double-sided worksheets 15 x 15 cm for 24 models
- instruction

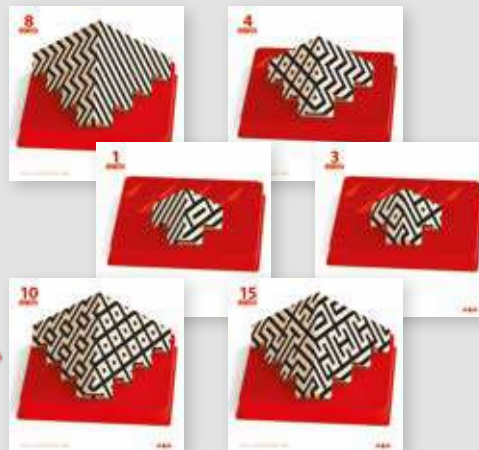

WORKSHEETS FOR LOGI-CUBE ZEBRA



9 Logi-cube Zebra cubes LA1209

- 15 double-sided cardboard worksheets with 30 patterns, 30 transparent printed check sheets, instruction
- 9 x 9 cm



16 Logi-cube Zebra cubes LA1216

- 15 double-sided cardboard worksheets with 30 patterns, 30 transparent printed check sheets, instruction
- 12 x 12 cm



25 Logi-cube Zebra cubes LA1225

- 12 double-sided cardboard worksheets with 24 patterns, 24 transparent printed check sheets, instruction
- 15 x 15 cm

LOGI-CUBE ZEBRA SET



9 cubes LA0009

- 9 cubes, grid transparent pad, instruction with 30 examples, box with a holder for cubes



16 cubes LA0016

- 16 cubes, grid transparent pad, instruction with 30 examples, box with a holder for cubes

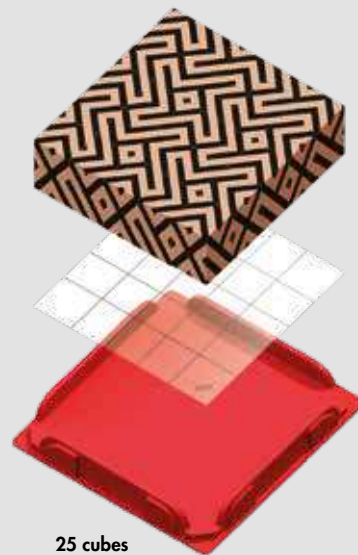

25 cubes LA0025

- 25 cubes, grid transparent pad, instruction with 30 examples, box with a holder for cubes

WOODEN BRICKS

Small beams

NS0373

- 60 pcs



Large beams

NS0374

- 120 pcs

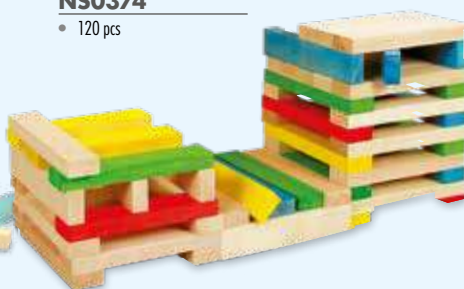

City Blocks

CI5005

This set includes 20 pieces of puzzle and 100 pieces of blocks that combine letters, numbers, mathematical symbols, and people images into the city buildings images.

- size: 63 x 43 x 15,5 cm
- age: 18 months +

Wooden bricks 1

SI2864

- 50 pcs



Wooden bricks 2

SI2868

- 100 pcs





**Wooden blocks
with colourful windows
RV0033**

A set of blocks thanks to which children can engage in many fun activities. Additionally, it will prove useful as an aid in sensory integration therapy. Wooden blocks with colourful acrylic windows encourage the creation of different constructions. They allow children to observe wonderful effects of sunlight passing through the coloured windows. The set not only supports the development of eye-hand coordination and visual perception but also stimulates the senses. It can be combined with a light panel.

- 24 pcs in 6 shapes: 4 equilateral triangles, 4 circles, 4 scalene triangles, 4 squares, 4 semicircles, 4 rectangles;
- windows in 4 colours: yellow, green, blue, red;
- material: wood, acrylic; age: 3+



**Baby walker with blocks
C16460**

- cart size: 29 x 27 cm; 26 blocks



**Zoo blocks
C13556**

Stacking blocks, telling story with animal blocks, doing math, letters and tangram, play is no limits for your kids.

- 100 pcs;
- size: 25 x 20 x 25 cm;
- age: 1+



**Blocks farm set
VG5028**

- includes: a set of 50 pieces (H 3 cm) packed in a carton bucket with a handle; a booklet with examples of constructions



**Ball track
NS0376**

- 42 blocks, 2 balls



PLASTIC BRICKS



Farm. Construction bricks TU0048

- 101 pcs; material: plastic



Marble run building blocks with base plates NS4073

Construction blocks for building a closed track for a marble. Thanks to the variety of elements constructions

can be made according to the needs of the child. Playing with building blocks teaches logical thinking and planning.

- 119 elements in different colours,
- including 4 green studded base plates 25,5 x 25,5 cm;
- age: 3+



Large plastic toy bricks TU0041

- 28 pcs;
- 2 x 2 block size: 9,5 x 9,5 x 8,5 cm,
- 2 x 4 block size: 19 x 9,5 x 8,5 cm,
- 2 x 16 block size: 38 x 9,5 x 8,5 cm
- plastic zip bag size: 38 x 20 x 41,5 cm
- age: 3+



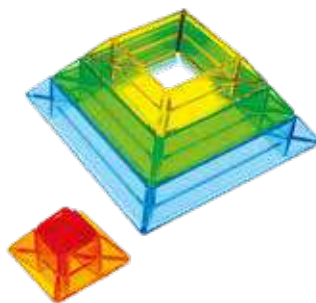

Transparent diamond JN0055

Set of transparent frames allows children to arrange or combine elements from which 3D structures, related to each other by size, can be created. Shapes in 5 sizes are also perfect for experiments with the illuminated panel. This set develops motor skills, spatial imagination, eye-hand coordination and the ability to think logically.

- 30 pcs, dim. of the biggest frame: 10 x 10 cm;
- material: plastic; age: 3+



People blocks TY6333

- 100 pcs, 5 colors, H 10 cm



Triangle puzzle Diamond TY6509

- 15 pcs



Wooden bear family TY3010

- 30 pcs;
- 6 colors

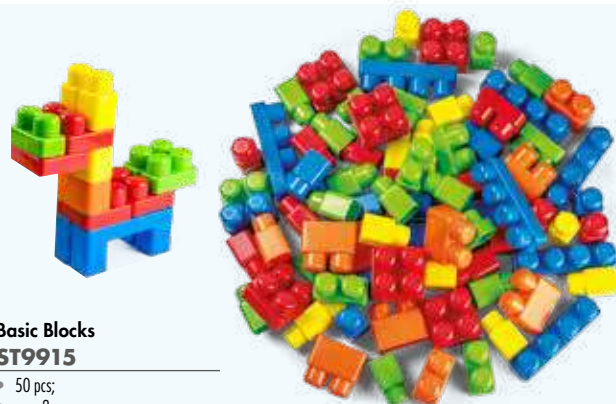

Basic Blocks ST9915

- 50 pcs;
- age: 2+



Maxi building blocks in a box ST8813

Plastic building blocks in attractive shapes. They develop a child's spatial imagination, manual skills and creativity. Excellent both at home and in educational institutions. All the elements come in a large plastic box to store them free of dust.

- 88 pcs in 5 shapes;
- box size: 37 x 23 x 22,5 cm;
- age: 3+

Pastel colour building blocks ST2248

A set of basic construction blocks for creative play. They are durable and easily connectable and they can be used for building 2D and 3D structures. They enhance the development of manual skills. After play they can be stored in a bucket with a lid and handle for easy carrying.

- 200 pcs on 7 shapes;
- package size: 24 x 29 cm;
- age: 3+

Basic Blocks in cup ST2247

- 200 pcs;
- size of cup: 24 x 29 cm;
- age: 3+



Maxi plastic ball tracker NS4113

This set allows children to boost their creativity by building tracks for balls.

- the set consists of 89 elements, including: 5 coloured balls, 60 simple construction bricks, 4 half-rounded construction bricks, 1 slalom-shaped construction brick, 2 bases, 2 funnels, 1 brick with a spinning wheel, 3 diagonal bridges, 8 snail-shaped bricks, 1 big funnel, 1 catapult





Bricks with animals NS4099

- 7 colours;
- 24 pcs



Gears Building NS4097

- the set includes:
 - 2 platforms (31 x 32 cm),
 - 12 wheels (D 6 - 12 cm),
 - 2 cranks,
 - 40 chain elements,
 - 30 pillars,
 - 84 connectors;
 - 170 elements;
 - age: 3+



Baby blocks NS4092

Colourful bricks with mobile elements of wheels, shutters, digits and various pictures on their walls. A great help in familiarizing oneself with numbers and producing simple mathematical equations.

- made of plastic; 63 pieces in a plastic bag; a manual provided with examples of equations, quotations and simple constructions





**Vehicles building blocks
with base plates**
NS4077

Plastic building blocks of various shapes for making cool constructions.

The base plates help designs to take shape. The set contains pictorial suggestions for beginners.

- 123 elements in different colours, including 4 green studded base plates 25.5 x 25.5 cm; age: 3+



Box with bricks. Mosaic
NS4035

- box size: 21 x 29 cm; 92 pcs



**Transparent and colourful
sorting cups**
JN0106

Colourful boxes made of transparent plastic, perfect for playing and sorting objects by colour and size. Equipped

with a lid with a convenient knob for easy opening and for stacking boxes one on top of another.

- 18 pcs.: diameter: 4,5 cm, height: 5,7 cm; colours: 3 x red, 3 x green, 3 x orange, 3 x blue, 3 x purple, 3 x yellow; material: plastic; age: 18 months +

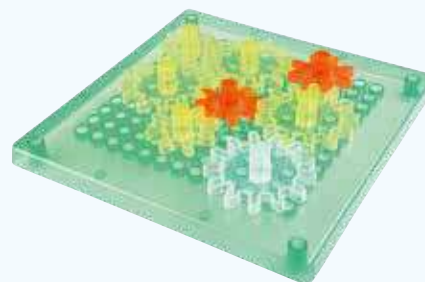

Transparent gears
AP2559

The set consists of transparent elements. It has special holes in which gears are placed. Gears placed on the board engage, and by rotating them in both directions, they set other elements in motion. This set can be used on any

flat surface, or it can be combined with the illuminated panel for an additional visual effect. The toy improves eye-hand coordination, trains fine motor skills and strengthens the tweezers grip.

- 9 pcs.: 1 x base dim.: 30,8 x 6 x 30,8 cm;
- 4 x big gears, 4 x small gears;
- material: plastic; age: 3+

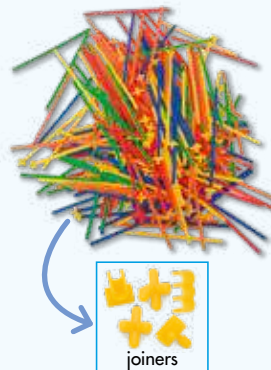

Straws set 1
RO6087

- L 20cm, ø 0,7 cm; 6 colours;
- 5 kinds of connectors; 1000 pcs

Straws set 2
RO6086

- L 20cm, ø 0,7cm, 6 colours;
- 5 kinds of connectors; 120 pcs



CARTON BRICKS

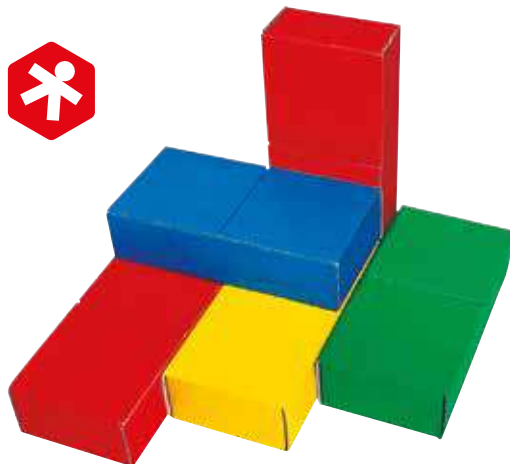

Cardboard bricks
NS1007

- 32 pieces in 4 colours; can hold the weight of an adult; size: 30 x 15 x 7,5 cm



FOAM BRICKS

Foam bricks
MW1940

- 40 pcs



Foam wood-like bricks
MW2940

- 40 pcs



MOSAIC



Color mosaic NS4074

- 48 studs in 8 colours;
- 12 activity sheet;
- age: 2+

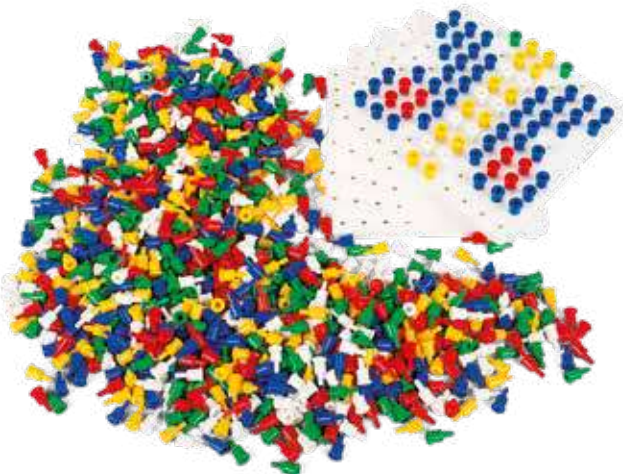

Boards with nails. Mosaic TY1405

- 5 boards, 1000 nails;
- board size: 16 x 16 cm

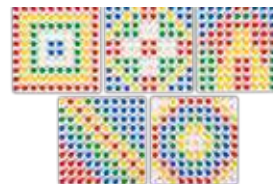



Create pattern with bead and ludo VG5999

A puzzle and a ludo game in one set.

- size: 40 x 3 x 27 cm;
- wooden box contains a double-sided board with games, beads in 9 colours, 24 worksheets with patterns and 4 wooden dice



Small pins. Mosaic PG0097

- 1500 nails, ø 0,9 cm, H 2,5 cm



Pins. Mosaic PG0098

- 600 nails, ø 1,3 cm, H 2,8 cm



Worksheets for PG0097 PG0097W

- 24 pcs; size: 11,5 x 11,5 cm



Worksheets for PG0098 PG0098W

- 24 pcs; size: 11,5 x 11,5 cm

Boards. Mosaic PG0220

- 5 pcs; size: 20 x 6 x 6 cm

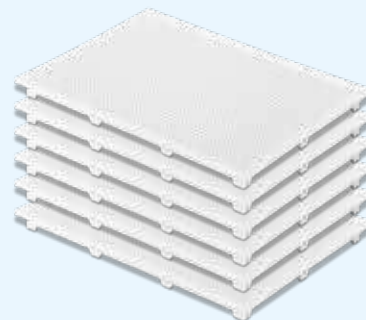

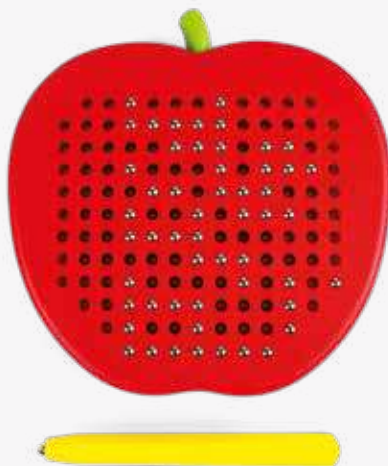

Magnetic apple with worksheets

UT0036

Magnetic puzzle in the shape of an apple. Metal balls are placed in holes on the board. The magnetic stylus makes the balls move to the surface of the tablet and it is possible to create patterns, letters or numbers. Each composition can be easily erased with fingers by pressing the balls into the centre of the board. This toy stimulates creativity, imagination and it develops motor skills. The puzzle is also a great aid in learning to count or to write letters and numbers. The set includes worksheets which allow children to familiarise themselves with a new technique of "painting".

- 1x board with metal balls,
- dim.: 12,3 x 2,4 x 12 cm, 1 stylus, worksheets;
- age: 3+





Magnetic board with magnetic pen EO3388

Use your imagination to draw, design and create. Push the beads down with a finger or pen to erase and start over; the beads are completely self-contained and do not come out of the board. Made from the highest quality ABS.

- size: 20,4 x 16,6 x 2 cm

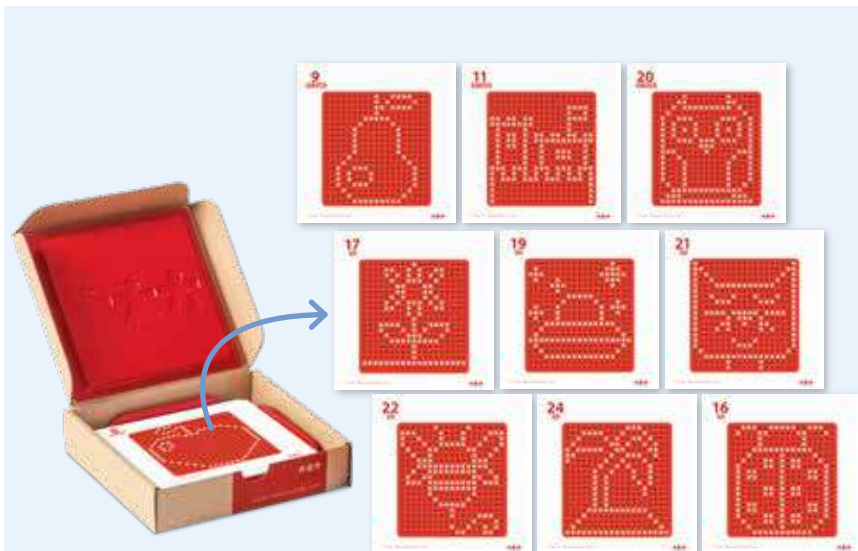

Worksheets for EO3388 EO3388W

- 24 pcs; size: 11,5 x 11,5 cm

Tack Zap - construction vehicles VG0336

Let the child create a vehicle by nailing pieces to the cork board. The set also contains worksheets with ready-made patterns.

- 52 elements: cork board, 45 flat pieces of different shapes, hammer, 5 one-sided worksheets, fasteners
- size: 22,5 x 18 x 4,5 cm
- material: wood, cork, metal
- age: 3+



ANIMALS

Large animal models great for theme games. Colours and attention to details makes the figures look real.

- made of plastic; age: 3+

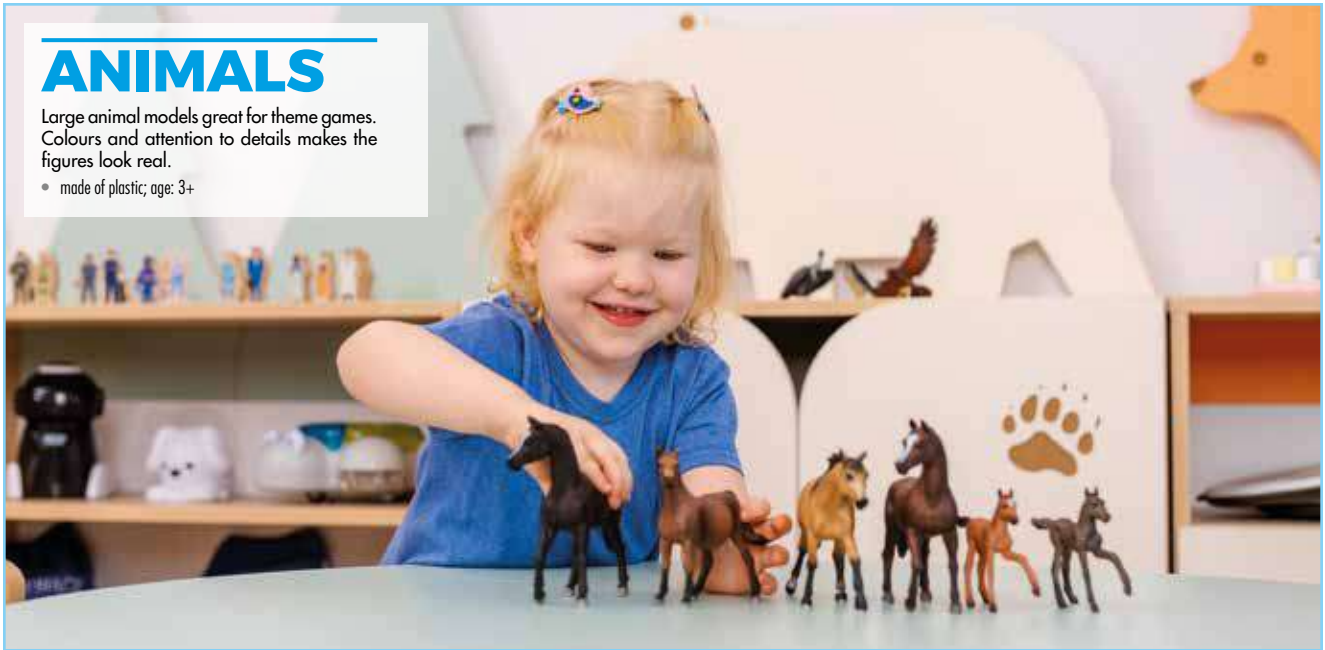

Horses

MJ0011

- 6 figurines: 4 horses, 2 colts;
- dim.: height from 12,3 cm to 7,5 cm;
- material: plastic;
- age: 3+



Exotic animals

MJ0001

- set of 7 animals:
elephant (16 x 10 x 8,7 cm),
tiger (15,5 x 3,8 x 6,5 cm),
lion (16 x 3,5 x 7,5 cm),
zebra (11 x 4 x 9,5 cm),
giraffe (13,7 x 3,7 x 13,7 cm),
kangaroo (12,4 x 4,3 x 9 cm),
leopard (14,3 x 4,3 x 12,4 cm)



Birds

MJ0012

- 5 figurines: an eagle, a falcon, a vulture, a parrot, an owl;
- dim.: length from 15,5 cm to 7,5 cm;
- material: plastic;
- age: 3+



Forest animals

MJ0002

- set of 8 animals:
moose (12 x 7,5 x 10,5 cm),
wolf (10 x 2,5 x 6 cm),
fox (7 x 2 x 5 cm),
squirrel (4 x 1,5 x 5 cm),
badger (7 x 2,5 x 3 cm),
deer (10,5 x 3,5 x 8,5 cm),
stag (11,5 x 7 x 12,75 cm),
beaver (8,5 x 3 x 3 m)



Prehistoric animals MJ0007

- the set contains:
 - a T-rex (18 x 4 x 8,5 cm),
 - triceratops (16,8 x 5,5 x 7 cm),
 - brachiosaurus (21 x 5 x 13,5 cm),
 - smilodon (12,8 x 3,8 x 7,6 cm),
 - tylosaurus (17 x 12 x 5 cm),
 - mammoth (20 x 10 x 13 cm);



Farm birds MJ0008

The set contains faithful copies of farm animals. It develops vocabulary and helps in remembering animal names.

- 5 elements:
 - hen (4 x 2,5 x 4,5 cm),
 - duck (6 x 2,5 x 5 cm),
 - rooster (6 x 2,5 x 6,5 cm),
 - turkey (6 x 4,5 x 6 cm),
 - swan (8,5 x 3,5 x 7 cm)



Farm animals MJ0003

- set of 7 animals:
 - hen (4,5 x 2 x 4,5 cm),
 - pig (9,8 x 3 x 4,6 cm),
 - sheep (10 x 3 x 7 cm),
 - ram (10 x 3,5 x 8 cm),
 - cow (14 x 4 x 7,5 cm),
 - horse (12,5 x 4 x 12 cm),
 - goat (11 x 3 x 9,5 cm)



Sea animals MJ0005

- set includes:
 - a whale (24 x 3 x 12 cm),
 - a killer whale (20 x 6,5 x 8 cm),
 - a shark (16 x 4,5 x 7,5 cm),
 - a dolphin (12,5 x 4 x 4,5 cm),
 - a seal (11 x 4 x 6 cm)



Polar animals MJ0004

- set includes:
 - a polar bear (10 x 6 x 3,5 cm),
 - a polar cub (6 x 4 x 3,5 cm),
 - an arctic wolf (11 x 5 x 3 cm),
 - a sea lion (9 x 6,5 x 9 cm),
 - a penguin (4 x 6 x 3 cm)



Rodents MJ0010

- set includes:
 - a badger (7 x 2,5 x 3 cm),
 - a beaver (8,5 x 3 x 3 cm),
 - a hedgehog (4,5 x 3 x 2,5 cm),
 - a mouse (6,5 x 3 x 2,7 cm),
 - an otter (9,5 x 2 x 3 cm),
 - a squirrel (4 x 1,5 x 5 cm)



Baby animals MJ0006

- the set contains: a colt, cow, calf, bull calf, piglet, puppy, kitten, fawn;
- H 1,5–7 cm;
- age: 3+



Dogs and cats MJ0009

- 7 elements:
 - a ginger tabby cat (8 x 2 x 6,5 cm),
 - white cat lying down (7 x 4 x 3,5 cm),
 - Dalmatian (9 x 3 x 7,5 cm),
 - Labrador retriever (9 x 2,5 x 7 cm),
 - Alsatian (12 x 3 x 7 cm),
 - Jack Russell terrier (6,5 x 2,5 x 5,5 cm),
 - golden retriever (10 x 3 x 7,25 cm)

EARLY YEARS



Musical player TU0030

A sensory toy with light effects and funny tunes in 4 modes (guitar, piano, harp, trumpet). On turning the dial and selecting one of the four animals (dog, cat, duck or goat) its sound appears in a song.

- size: 15 x 8 x 41,5 cm;
- needs 2 AA batteries (not included);
- age: 18 m+



Rainy rattle CI4052

- dim.: 6,5 x 6,5 x 16 cm;
- material: plastic, wood, metal; age: 2 +



My first telephone CI3627

My first telephone is a fantastic toy which stimulates toddlers' imagination. To play pleasant tunes, children should press buttons and to call, they should shake the phone. The toy has a mirrored front in which children can see their reflection. Activity with the telephone develops the ability to communicate and awakens cognitive curiosity.

- dim.: 6,5 x 2 x 16 cm;
- 3 LR44 batteries are necessary (not included);
- material: wood; age: 10 months +



My first camera CI3634

Classic camera equipped with a lens, a red shutter button and a flash lamp imitation. The lens in the form of a checkered glass multiplying the image which can be set in motion by turning the lens ring. Thanks to this, it is possible to obtain a kaleidoscopic effect. This toy develops imagination, creativity, manual and cognitive skills. A wrist strap prevents the camera from falling.

- dim.: 15 x 7,5 x 5 cm;
- material: wood;
- age: 10 months +



Toddler's ball TU0050

- 1 pc; dim.: 11 x 11 x 11 cm;
- material: plastic;
- age: 1+





Multifunction cube TU0033

The cube has 5 activity sides for various manipulations: propellers, abacus, sound alphabet, small piano, sounds of drums, cymbals and maracas, rattling monkey.

- 2 language modes: English and Spanish;
- needs 3 AA batteries (not included);
- size: 17 x 17 x 17 cm; age: 18 m+



2 in 1 fitness frame piano TU0037

This floor mat with an interactive piano will grow with the baby. In the first months, when the baby lies on the back it can play with the toys on the arch and press the keyboard keys with its feet. When it starts to lift its head and lie on its tummy, it can face the keyboard. When



it has learned to sit, the piano can be set up in the table position. The keyboard panel can also be detached and mounted onto the bed. Keyboard with 4 large keys and a function key, 5 rattles with hooks (including 1 music box)

- mat size: 70 x 83 x 45 cm;
- requires 3 AA batteries and 3 AG13 1.5V batteries (not included);
- age: 6 m+

Activity Walker CI3302

A wooden walker on rubber wheels, equipped with many manipulative elements (rotary mirror, sorter, maze, cogs, bells with a stick).

- size: 34 x 34 x 47 cm;
- age: 1+



Shopping Cart VG0672

Wooden toy.

- size: 48 x 41 x 30 cm;
- age: 12 m+





Workshop on wheels VG4066

A workshop on wheels equipped with everything a young DIY enthusiast might need to screw in screws, tighten the slats, hammer nails and take measurements.

- a hammer, a screwdriver, a ruler, a key, screws, nuts, nails, gears;
- dim.: 48,8 x 49,5 x 32 cm;
- material: wood;
- age: 18 months +



Wooden toy pusher Robot CI0515

Robot is a great companion of children starting to learn to walk. It is equipped with 4 wheels and a height regulating handle which can be adapted to the child's height. Magnetic arms can be set in several positions. The toy pusher has many manipulative elements, for example:

moving eyes, xylophone, 3D shapes sorter, gears, mirror, spatial labyrinth. Thanks to the regulated speed limiter the product is safe to use. Open glove compartment allows children to store their trinkets or toys. The pusher trains small and large motor skills.

- 5 pcs: 4 bricks, 1 pusher dim.: 30,7 x 35,5 x 47,9 cm;
- material: wood, MDF board; age: 1+



3 interactive buttons
for playing melodies



Lion walker with music & light TU0035

The toy has a convenient handle, a switch for volume control (2 levels), a minibus, a rotary wheel with pictures of animals, a sliding butterfly, a book with

a mirror, pink balls for turning around, 3 interactive buttons for playing melodies, a button on the nose to emit the lion's roar, and a press horn.

- maximum load 20 kg;
- age: 12 m+



2in1 walker-pusher CI0509

Walker-pusher in beautiful pastel colours equipped with two handles and manipulative elements: sorter, gears, puzzles and mini labyrinth. Long handle on the back of the vehicle is used to drive the pusher which makes it easier for children to take their first steps. The other handle on the front ensures safety

while driving. On the sides of the walker-pusher are holes in different shapes, corresponding to the bricks included in the set. This product supports motor development and improves eye-hand coordination. Wooden frame with rounded edges guarantees safe playtime.

- dim.: 47 x 22,5 x 42 cm;
- 4 bricks included in the set;
- material: wood; age: 18 months +



a horn in the
handlebars



Baby walker bike TU0039

This small walker bike for toddlers can be used both indoors and outside, a moulded seat, a horn in the handlebars.

- size: 48 x 22 x 41 cm;
- seat height 22 cm;
- maximum load 25 kg;
- age: 12 m+



Food truck TU0032

The multi-functional vehicle can turn into a toy ride-on car or a mobile kitchen. Easy to carry around. Elements: spoon, strainer, spatula, pot with lid, pan with lid,

potato, 2 maize ears, aubergine, carrot, chicory, ketchup, sauce, pasta, fried egg, 3 shelves, handle with hooks.

- size: 32 x 32 x 21 cm;
- maximum load: 20 kg;
- age: 3+

PLASTIC TOYS



Farm animal train FT5913

Toys introduces playable push toys with functionality (turn wheel for tractor movement). Removable figure and animal to add to open ended play concept.

- age: 12 m+



Toy Tool Set TU0031

A set of 4 toy tools.

- spirit level (17,5 x 4 cm), tape measure (6 x 6 cm), battery-powered drill driver with 2 detachable bits (13 x 12 cm), jigsaw with a detachable blade (13 x 16 cm)
- 4 AA batteries required (not included); age: 3+



Busy day activity set FT5923

A multi-piece threading set consisting of:

- 4 perforated animals, 4 large spools, 3 strings, 2 safe needles, 4 buttons, 6 threading plates featuring clothes;
- age: 3+



Magnetic tablet TU0036

The tablet can be drawn on with a magnetic pencil and 4 animal-shaped stamps (hare, dog, cat, duck). The image can be erased with a slider to make room for new pictures. Easy to carry thanks to a convenient handle. Difficult to lose thanks to the attached string.

- size: 31 x 3 x 30,5 cm;
- age: 3+



Pin art board. Educational aid HG0069

Creative mosaic made of safe pins. They allow children to make an imprint of whatever they want in the form of 3D reflection. This toy is suitable for younger and older children, and it guarantees many hours of great fun. It develops creativity, imagination, spatial perception as well as stimulates the senses.

- dim.: 12,5 x 5,5 x 9,5 cm; material: plastic;
- colour chosen at random; age: 3+



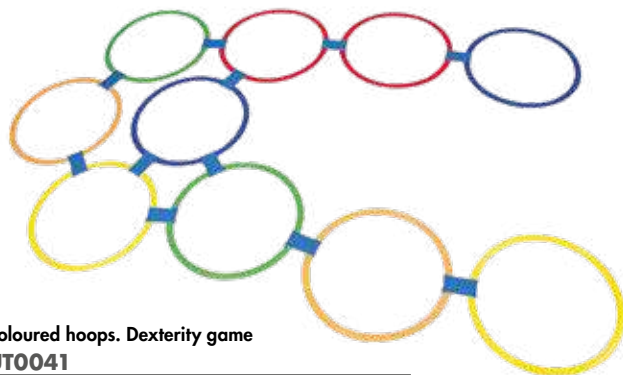

Coloured hoops. Dexterity game UT0041

This game helps to develop motor coordination and creativity. Rings can be freely combined with each other to provide lots of fun.

- dim.: 29 x 29 x 7 cm



My first puzzle with rattles JN0038

„My First Puzzle“ for toddlers is an easy and interesting introduction to the development of motor coordination, perception and association skills. It is also a perfect for the development of fine motor skills. The set contains colourful and differently shaped pegs - rattles filled with beads. The baby can freely place the elements in the base or attach them to other pegs to

form towers. This product also teaches sorting by colour or shape. Pegs are quite big, easy to grab and manipulate. They exercise motor skills and eye-hand coordination.

- 22 pcs: 18 pegs in different colours (green, blue, red, yellow, purple) and shapes (circle, star, triangle, flower), 3 transparent pegs with beads and a base;
- material: plastic; dim. of the peg: 4,5 x 5,5 cm;
- dim. of the base: 28 cm, height 6 cm;
- packaging: cardboard box;
- age: 18 months +



Hand-trampoline paddle ball set VX0040

A set of paddles that are used to bounce and receive balls. Equipped with flexible material and comfortable handles that make it easy to hold and maneuver. The equipment allows you to carry out team games and games in gyms and outdoors.

Product specification:

- 9 items: 6 paddles, diam. 40 cm in 6 colors: navy blue, purple, red, orange, green, yellow;
- 3 balls diam. 7 cm in orange;
- material plastic;
- age: 6+



Transparent tweezers. Classroom set JN0002

Tweezers for gripping and carrying objects. They teach precision and help to develop hand-eye coordination. Exercises with tweezers also prepare the children for learning to write.

- 6 pcs: dim. 14 x 2 x 5,5 cm;
- colour: purple, red, yellow, blue, green, orange;
- material: plastic;
- packaging: plastic bag;
- age: 3+



Transparent and colourful sorting set with tweezers JN0083

Set for playing and for practicing precision, grip, and developing hand-eye coordination. Equipped with transparent trays, special tweezers and colourful elements for gripping and carrying. This set exercises the hand and prepares for holding writing tools. It also

helps younger children to learn colours and sort things by specific categories.

- 60 pcs: 6 semi-transparent trays dim.: 24 x 4 x 16,5 cm in red, orange, green, yellow, purple, blue;
- 6 semi-transparent tweezers dim.: 4 x 1 x 5,5 cm in red, orange, green, yellow, purple, blue;
- 48 semi-transparent gems in red, orange, green, yellow, purple, blue;
- packaging: plastic bag;
- age: 3+



Transparent sound cubes with mirrors JN0082

Transparent cubes with mirrors and beads inside. They are an excellent sensory aid that supports the development of hand-eye coordination and activates the sense of sight and hearing. With these

bricks, it is possible to create original, transparent constructions or experiment with a reflected image by putting them next to each other.

- 18 pcs: meas. 5 x 5 x 5 cm;
- material: plastic;
- packaging: plastic bag; age: 18 months +

WOODEN TOYS



Musical table CI0529

This colourful table creates space for developing musical abilities and encourages children to experiment with sounds. Equipped with musical instruments which will allow children to create original melodies and train their sense of rhythm. The selection of

instruments is suited to children's age and abilities. The arrangement of the set's elements on the table top ensures easy access to each instrument.

- size: 50 x 29 x 27 cm;
- instruments: 8 tone xylophone, tones are marked with different colours, triangle, bell, drum cymbal, 2 drums, small Guiro grater, 2 drumsticks;
- material: wood, metal; age: 18 months +



Manipulation and sound pyramid CI4723

Creative pyramid will provide a lot of fun for the children. Each side of the toy has different elements engaging the senses and stimulating the child's development from an early age. It is equipped with gear wheels, musical

instruments (xylophone, Guiro grater, bell, sound button), mirror with a wheel showing various emotions. Large knobs on all vertices permit to easily move the product and ensure safe handling.

- 4 pcs: pyramid, 3 bricks (square, circle, triangle);
- size: 33 x 35 x 29 cm;
- material: wood, metal; age: 3 +



Happy Hen. Manipulation and sound box CI0172

This hen activity box combines many children's favourite functions: xylophone, maze, bead coasters,

gears, shape sorter. It is perfect for practising hand-eye coordination and fine motor skills.

- size: 31.5 x 26.7 x 42.5 cm
- material: wood, metal;
- age: 18 month+



Wooden cash register CI4167

A cash register allows children to play out various scenes which may take place in the shop. They can choose to become a cashier or a client and, in the meantime, learn to count and give change. Playtime with the cash register also supports the development of communication skills. The toy is equipped with a drawer which opens

at the push of a button (accompanied by a ringing sound), a scanner, an abacus, a display, and a place to swipe a credit card.

- wooden cash register, dim.: 19 x 20 x 15 cm;
- 15 double-sided paper banknotes: 10, 20 and 50;
- 15 wooden double-sided coins: 1, 5, 10;
- 1 x paper credit card;
- 9 barcode stickers with space for the price;
- material: wood, paper;
- age: 3+



Wooden abacus VG5971

A classic abacus with a bright and bold red twist.

- size: 31 x 24 x 14 cm



Pull-along train stacker VG0089

The set consists of an engine and two carriages formed by stacking blocks of different shapes onto wooden pegs.

- 25 elements: 22 blocks, engine with a 61 cm string, 2 carriage;
- size: 46,5 x 8 x 12 cm;
- age: 3+



Magnetic trace and match Farm VG5019

Comes with 1 magnetic stick which is used to trace the magnetic characters to their corresponding pattern on the base board. Contains 10 pieces to match. A special slot on the top to keep your magnetic stick stored.

- size: 22,5 x 22,5 x 1,7 cm





Crocodile
C10470

- size: 23 x 8 cm; 18 cylinders



Domino
C12437

- 28 blocks, size: 7,5 x 3,7 cm;
- wooden box 10 x 5 x 17 cm



Multi-activity rocket
C14121

- size: 37 x 37 x 62 cm;
- age: 18 m+



Rollercoaster Table
VG0670

Big enough for several children to play together. Multiple functions: rollercoaster of colorful wires with wooden beads;

movable blocks (a farmer, a tractor and 3 animals) on a track; turning gears and a windmill. The table legs are made of solid beech wood with secure connection to the table top.

- size: 60 x 81 cm;



Rocket CI0528

This wooden rocket is a perfect toy for a little constructor and cosmonaut. It guarantees great fun during the assembly of the space ship and many hours of group play. The rocket has different functions and interactive elements to explore. The space ship with beautiful details hides inside 4 levels of 12 rooms with equipment: bedroom,

operating theatre, laboratory, etc. Unique design of the rocket will be a source of joy for children and their friends. It also teaches precision, to recognise shapes and develops manual skills.

- 50 pcs: meas. when assembled: 31 x 31 x 69 cm;
- material: wood, MDF board, plastic;
- user manual;
- meas. of the packaging: 56 x 12 x 40 cm;
- age: 3+



Magnetic fish. Game VG6305

Popular arcade game for little anglers. The task is to catch as many colourful fish as possible. This product is especially recommended for children learning to count, name colours and to match objects. It develops hand-eye

coordination but also teaches patience and precision.

- 4 magnetic fishing rods, 20 colourful fish imprinted with numbers in the range 1-20, 4 panels creating the lake;
- dim.: 25 x 19 x 4 cm;
- material: wood, magnet;
- age: 24 months +



Fish CI2579

- size: 25 x 25 cm



Magnetic fish. Table VG4546

Table for little fisherman with magnetic fish and fishing rods included in the set. This toy guarantees many hours of great fun which at the same time develops manual skills, dexterity and eye-hand coordination. On the backs of all the

fish numbers from 1 to 10 are placed to facilitate learning to count and to associate numbers with quantity.

- dim. of the table: diam.: 45 cm, height: 11 cm;
- elements: 1 table, 4 fishing rods, 40 fish in four colours;
- material: wood, magnet, fitting elements: 4 x screws;
- age: 2+



Magnetic fish puzzle EO2181

Magnetic puzzle game – fish and a rod. Players can put the fish on the board or pick them up.

- dim.: 22 x 26 x 1,2 cm; age: 3+



Little fisherman. Wooden dexterity toy C10111

Rich set of elements, including magnetic ones, which offer 3 kinds of activity. Happy seal with fish allows children to train dexterity. The task is to place as many fish as possible on the seal's back. The seal has holes in the side wall with rods of various lengths inside



them to create a sorter for layering fish. Additionally, such an activity develops fine motor skills and logical thinking. Pond in the form of a round pad, magnetic fishing rods and fish allow children to organise a fishing contest.

- 24 pcs: 1 seal/ sorter base, 5 rods, 15 magnetic fish, 1 pond, 2 fishing rods;
- material: wood, magnet;
- age: 18 months +



Wooden train on a string C10508

The train consists of 17 bricks in different shapes and colours. Each car has a different shape. Laser engraved texture on the manipulative elements additionally stimulates the sense of touch and supports cognitive development in children. Removable shapes develop creativity

and improve fine motor skills. Toddlers can freely arrange the bricks in order to design their own train. Wooden bricks allow children to develop manual skills, spatial imagination and the ability to create their first constructions. A string included in the set facilitates the movement of the train.

- dim.: 42,7 x 7,5 x 11,8 cm;
- 17 bricks; material: wood; age: 1+



Sliding puzzle with worksheets E01861

A simple and easy-to-use logic game which also improves fine motor skills. The wooden puzzle is a frame embracing 8 square tiles in different colours and one square empty space

for sliding the elements. Each tile has a small knob for easier sliding. The worksheets provided present examples of tile combinations.

- size: 19 x 19 x 3,7 cm;
- 6 worksheets;
- age: 3+



Board with screws C10180

This toy is equipped with a board with holes and a set of screws. By tightening the screws using a screwdriver, children improve their coordination, grip and concentration.

- the set includes: a screwdriver, 25 screws in 5 colours and shapes, 7 worksheets;
- dim.: 25 x 3 x 22 cm;
- material: wood;
- age: 3+



Memory bingo

EO1601

The aim of this memory game is to remember the locations of pictures and find a matching card.

- 4 doubledised charts with pictures;
- 16 lids with handles, wood;
- size: 28,5 x 5 x 29,5 cm



Balancing frogs

CI0098

Colourful wooden arcade game which guarantees many hours of great fun. The children's task is to alternately place the frogs on a balancing water lily in such a way as to keep it in balance for as

long as possible. This game develops eye-hand coordination and motor skills. It also improves concentration, patience and dexterity.

- 1 balancing base
- dim.: 18 x 18 x 7,5 cm, 8 frogs,
- 1 flower; material: wood; age: 10 months +



Horse farm

VG4502

Amazing set which will inspire fun and creative activities. It will allow the children to play the role of horse breeder. The set includes folding stable with 4 boxes that makes for a comfortable home for horses. Play time with this product improves the

imagination, develops manual skills and trains hand-eye coordination. The toy is entirely made of beech wood painted with non-toxic paints in subdued colours.

- meas. of the stable: 24,5 x 16,5 x 15 cm;
- the set includes: folding stable with 4 boxes, 5 horses, 4 elements of the fence, 2 hay bales, 2 troughs;
- material: wood; age: 3+

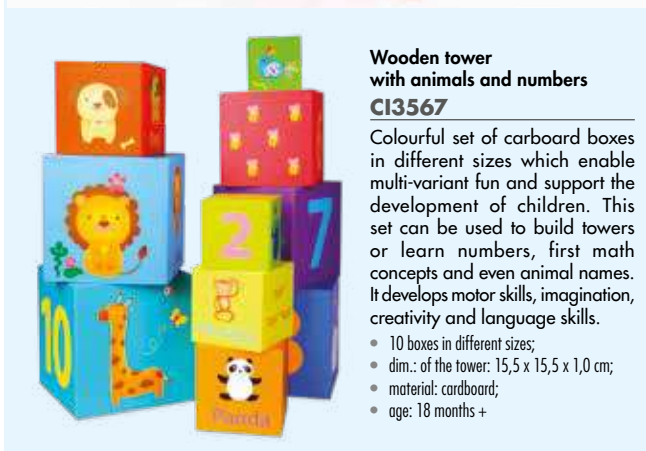

Wooden tower with animals and numbers

CI3567

Colourful set of cardboard boxes in different sizes which enable multi-variant fun and support the development of children. This set can be used to build towers or learn numbers, first math concepts and even animal names. It develops motor skills, imagination, creativity and language skills.

- 10 boxes in different sizes;
- dim.: of the tower: 15,5 x 15,5 x 1,0 cm;
- material: cardboard;
- age: 18 months +



Tool Bench CI0980

- size: 40 x 29 x 56 cm



Car slider buildings VG5098

This high quality and strong car slider includes 4 mini cars. Just put the cars one by one at the top of the slider, then watch them slide down.

- size: 35 x 37 x 10 cm;
- age: 2+



Garage VG5996

This 2-storey garage comes complete with 3 cars, 1 helicopter, 1 gas station, 1 elevator, 1 car wash station, 1 helipad and several car parks.

- size: 39,5 x 27,5 x 25 cm;
- age: 3+

Cutting food play set VG6219

A set of food products in a wooden box which are meant for cutting. The pieces are held together with Velcros.

- 18 elements: cutting board, 2 knives, 6 foodstuffs: roll (2 parts), wheat bread (4), tomato (3), toast bread (3), pepper (2), egg (2);
- wooden box with an acrylic glass top 21 x 6,5 x 14,5 cm;
- material: wood;
- age: 18 months+



Catch and Sort. Dexterity game VG4574

Puzzle developing manual skills, dexterity, eye-hand coordination and logical thinking. It also trains patience, precision of hand movements as well as stimulates imagination. This toy contains wooden balls, which should be moved to the base with holes using sticks, spoons or tweezers in order to create colourful patterns. First, children

have to fish out the ball they need from the rest, position it properly in their fingers and then throw the ball in the hole on the board. Mosaics can be arranged based on the suggestions from the worksheets or children's ideas. The entire set is kept in a box with compartments.

- 94 pcs: 80 balls in 8 colours, 1 spoon, pair of sticks, 1 tweezer, 10 worksheets with patterns; material: wood; age: 3+



Tetris. Jigsaw puzzle UT0040

Puzzle containing four games: Tetris, Tangram, Huarong Road and

mushroom puzzle. All elements of the set can be easily placed on the board or taken off of it.

- dim.: 27 x 18 x 1,5 cm; age: 3+

CARS



**Dustbin lorry with lights and sound
TU0051**

• dim.: 18 x 10 x 11 cm; material: plastic; age: 3+



**Digger with lights and sound
TU0054**

• dim.: 20,5 x 10,3 x 16 cm; age: 3+



**Cement mixer with lights and sound
TU0056**

• dim.: 19 x 10,5 x 15 cm; age: 3+



**Tipper lorry with lights and sound
TU0055**

• dim.: 18 x 13 x 10 cm; age: 3+



- cars with moving parts
- 1 pc., size: 15 x 10 x 11 cm
- age: 3+
- until stock runs out



**Set of construction engineering cars
TU0025**



**Bulldozer car
TU0026**



**Toy excavator
TU0027**



**Toy road roller
TU0028**



**Toy tipper truck
TU0029**



Transport plane with a mechanic TU0059

An aeroplane which can be used for the transport of 5 engineering vehicles, such as a digger, a dozer, a tipper lorry, a dustbin lorry and an oil tanker, included in the set. It also provides parking space for them. A figurine of a mechanic is also included in the set.



Car Transporter CI3591

This double-decker car carrier has a moveable ramp and helps promote & develop fine motor skills. Enhance manual dexterity and creative play!

- size: 27,5 x 7 x 14 cm;
- age: 2+



Mini Vehicles Set VG5962

- 6 pcs;
- age: 18 m+



Crane Truck VG0690

A nice wooden toy of crane truck contains four container blocks to play

with. The crane stand can turn around and the arm can move up and down perfectly.

- 1 car; 4 magnetic blocks; size: 29 x 9,5 x 8 cm



Wooden fire station VG0828

The ground floor houses a garage with an openable door. The first floor is the command post. The roof is a landing; platform for helicopters

- 15 elements: fire station building 32 x 25,5 x 28,5 cm, 2 firefighters, fire engine, hydrant, bunk bed, chair, control desk, ladder, dog, dog's bowl, flame, fire hose,
- no entry barrier
- age: 3+

ROLE PLAY



TEDDY BEARS

Ben NS2657

Soft teddy bear Ben dressed in a white shirt, perfect companion during play or relaxation time.

- dim.: bear in a sitting position – 23 cm;
- it has got plastic eyes



Hugo NS2658

Teddy bear Hugo dressed in white shirt. This smart bear is a great companion of children's games.

- dim.: bear in a sitting position – 23 cm;
- it has got plastic eyes

Bobi NS2659

Big light brown teddy bear Bobi with plastic eyes. It is dressed in a white shirt.

- dim.: bear in a sitting position – 30 cm



Luke NS2660

Big dark brown teddy bear Luke with plastic eyes. It is dressed in a white shirt.

- dim.: bear in a sitting position – 30 cm

Bear 16 cm
NS2037

Bear 24 cm
NS2038

Bear 27 cm
NS2039

Bear 32 cm
NS2040

Teddy bear set - family
NS2041

- 4 pcs: 16, 24, 27 and 32 cm



Sensory Frog
NS2055

A sitting soft frog with peas hidden in its toes and trunk. The peas add to the weight and provide sensations which stimulate touch.

- H 15 cm; age: 6 m+



Cuddly Dog
NS2056

A cuddly toy for the youngest. A piece of soft fabric with a dog's head for playing and cuddling

- dim: 34 x 30 cm
- age: 0+



Raccoon
NS2058

The contrasting black and white attract the eye and the thin paws and the soft tail make grasping easy.

- H 26 cm
- age: 6 m+



Bunny Rabbit
NS2059

A large and soft plush bunny rabbit. Its long ears invite the child to grasp them and its soft belly can easily serve as a pillow.

- H 50 cm; age: 6 m+



SOFT TOYS



Fruit Cubes
NS2116

A set of soft colourful velour-covered foam cubes with fruit motifs. They can serve as large and light blocks to build towers and pyramids. They can also be used to improve throwing and catching skills and to teach colours and fruit names

- 6 pcs; side 15 cm; machine washable zipper cover (max 40°); age: 6 m+



Sensory Cushions
NS2129

Soft rustling cushions in the shape of a circle, triangle, rectangle and square. The vivid colours attract children's attention and the rustling sound encourages them to play.

- rectangle 40 x 28 cm, square 30 x 30 cm, circle ø 30 cm, triangle side 30 cm
- granulate inside



Dolls of the World
NS2061

The four girls - Naomi, Klarissa, Emily, Yoko - come from different parts of the world. The appearance of each doll is characteristic of her place of origin. Made of soft fabric, wadded.

- 4 dolls, H 35 cm

SOFT DOLLS

They are soft, pleasant in touch and they come in different sizes. Their happy faces and colorful clothes will appeal to both boys and girls.



Girl 35 cm
CB0001



Girl 50 cm
CB0002



Boy 40 cm
CB0003



Boy 50 cm
CB0004



Girl 20 cm
CB0005



Boy 20 cm
CB0006



Baby
NS2045
• H 32 cm





Mati 1
NS2051

• H 20 cm



Mati 2
NS2052

• H 35 cm



Mati 3
NS2053

• H 50 cm



Nati 1
NS2047

• H 20 cm



Nati 2
NS2048

• H 35 cm



Nati 3
NS2049

• H 50 cm



MANIPULATIVE DOLLS

Large soft dolls dressed in several layers of clothes with different fastenings (wooden and plastic buttons, studs, velcros, zips, laces and buckles). Playing with the toy, the child develops dexterity and self-reliance.

- H 75 cm



Tola
NS2054

- 4 clothing pieces



Tolek
NS2065

- 6 clothing pieces



Baby
NS2067

A soft doll with a set of 8 garments with assorted fasteners. (velcro, zipper, lace)

- H 44 cm



ANATOMICAL DOLLS

Anatomically correct baby girl and baby boy soft dolls. Dressed in easy-to-change rompers and a blouse/shirt. Stuffed with bean bag beans and wadding. Their weight - nearing that of a real baby - makes them very realistic.

- H 48 cm



Soft baby. Girl
NS2042

Soft baby. Boy
NS2043

DOLLS



Family. Small dolls VG4061

The figurines have movable arms and legs which can be bent and put in different positions.

- 4 dolls: mum, dad, daughter, son; dim. of the figurine: dim. 8,5 cm; material: wood, plastic; age: 3+



Teenager doll TU0042

This large freestanding doll has movable arms, movable head and styleable hair. The doll is dressed in dungarees, T-shirt and gym shoes.

- size: 45 x 15 cm; age: 3+



Baby Doll TU0005

A soft talking baby doll with a dummy.

- H 42 cm;
- the clothes design is subject to alteration



Fashion doll TU0002

A large smiling doll in colourful clothing. After pressing a button on her tummy it will start singing merry songs.

- H 50 cm;
- different randomized clothing designs



Doll Miss Summer TU0001

A sunbathing doll in a swimming costume, sunglasses and frilled flip-flops. Instead of the navel it has a button - on pressing it the doll will say 'bye bye', cry, laugh, babble or sing. After being bottle-fed it will pee. The doll has movable legs and hands and can be seated. The set includes a feeding bottle, a shell, a starfish and glasses for the girl identical to the doll's.

- 3 batteries LR44 required; H 38 cm; age: 3+





Baby Doll with Accessories

TU0004

A baby doll ideal for all girls. The doll will shut its eyes when given a dummy and it can pee.

- H 40 cm; made of durable material;
- 8 accessories: 2 dummies, a chamber pot, a bottle, 3 portions of baby porridge, a nappy, a spoon, a bowl;
- the clothes design is subject to alteration



Interactive Baby Doll

TU0008

The doll can play a melody, crawl and look around. It will lie down on its tummy, calls its

mum and dad in English, open and close its eyes when changing position.

- accessories: clothes, bib; H 33 cm
- 3 AA batteries required (batteries not supplied)



Baby at the doctor's office

TU0058

Doll with medical accessories. Playtime with this doll teaches children empathy and responsibility. The set includes: a stethoscope, a syringe, a thermometer, a medicine box, two ampoules of medicine and bandages.

- age: 3+



Baby in the bath

TU0052

An interactive doll dressed in a bathroom dress. The set includes a bathtub, a towel and a bottle. The doll has 6 sound effects activated by the switch.

- batteries: LR44 – 3 pcs (not included);
- height: 28 cm;
- dim. of the bathtub: 25 x 3 x 22 cm;
- age: 3+



Nurse doll

TU0053

Doll with accessories – Nurse. The set includes: a stethoscope, a microscope, a mask, a syringe and a nurse's briefcase. The doll is dressed in a nurse uniform.



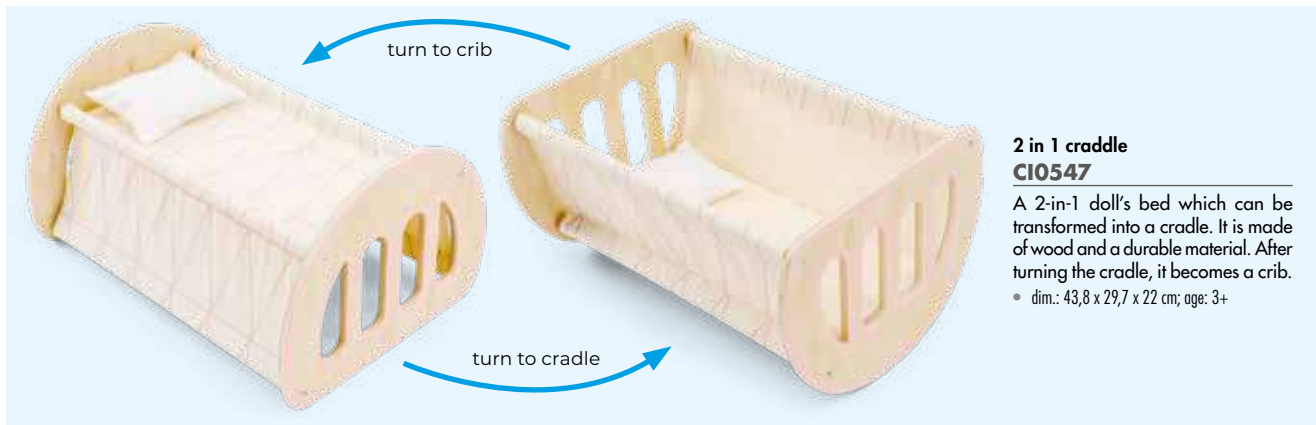

2 in 1 cradle CI0547

A 2-in-1 doll's bed which can be transformed into a cradle. It is made of wood and a durable material. After turning the cradle, it becomes a crib.

- dim.: 43,8 x 29,7 x 22 cm; age: 3+

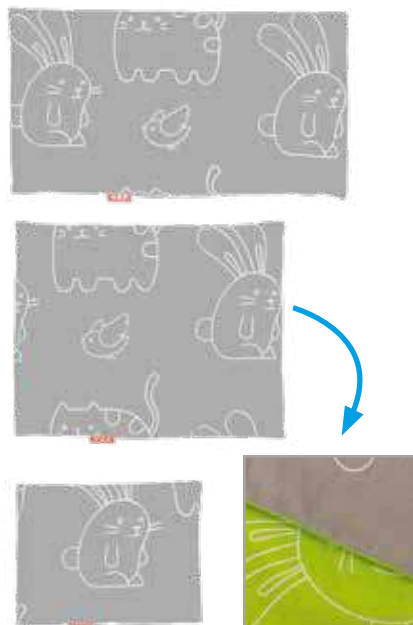

double-sided

Doll's bedclothes DO0006

Set contains

- a sheet (43 x 23 cm),
- a quilt (33 x 26 cm),
- a pillow (22 x 16 cm)
- double-sided: green and grey





Wooden doll pram
CI0549

A doll pram with a wooden frame.

- dim.: 43,2 x 32,5 x 50,5 cm, age: 3+



Mini wooden dressing table
CI0543

It is made of wood and painted with subtle colours. The set includes a comb, a lipstick, a straightener, a bracelet,

a ring, a makeup brush, a powder-box. This dressing table with accessories is perfect for playtime involving roleplay and it can boost children's creativity.

- dim.: 17 x 23 x 35,6 cm, age: 3+



DOLL ACCESSORIES

Fabric pattern may vary



Stroller for 2 dolls MI0160

A stable stroller with a double seat for dolls and teddy bears. The swivel front wheel makes the stroller manoeuvrable and easy to drive. The front seat is removable, and the handle is covered with soft foam. The seat's fabric is fixed

with press studs. The harness is located inside both seats. Under the stroller, there is a basket for accessories.

- Seats for 2 dolls;
- Swivel front wheels 360°;
- Detachable front seat;
- dim.: 58 x 38 x 65 cm;
- material: metal frame, polyester fabric; age: 3+



Doll pram MI7570

- size: 56 x 36,5 x 64 cm



Doll stroller MI0306

- 3 wheels
- size: 53 x 62 x 32,5 cm



Doll pushchair IK2332

- size: 52 x 27 x 50 cm



Seat for an infant MI7580

- size: 33 x 26 x 60 cm



Ironing board MI0207

- size: 51 x 18,5 cm



Doll accessories Iron TU0018

An interactive iron which makes sound effects while in use. The toy resembles the real iron.

Product specification:

- dim.: 19 x 9 x 10 cm;
- it requires 2 AA batteries (not included);
- material: plastic; age: 3+

DOLL HOUSES



**Doll house
NS0155**

- size: 56 x 56 x 55 cm



**Frame wooden doll house
NS0197**

A wooden doll house on pillars. Four rooms equipped with wooden furniture and an escalator. A handle at the top for easy carrying.

- size: 65 x 31 x 59 cm
- 20 pcs of furniture 4 clothed figures



**Wooden doll house
NS0198**

A wooden doll house with a sliding front and removable roof. Four rooms equipped with small wooden furniture. Access from three sides.

- size: 50 x 30 x 46 cm
- 20 pcs of furniture, 4 clothed figures

furniture are not
part of the set



**Butterfly wooden doll house
NS0199**

A large painted doll house with multiple rooms and removable roof for easy access. The house has openable doors and shutters.

- size: 50 x 30 x 60 cm; 3 storeys (ground floor, first floor and attic);
- the furniture and figures are not part of the set

WOODEN KITCHEN

MINTY KITCHEN ISLAND



A set of wooden furniture which imitates kitchen equipment. The overprints on the doors add a realistic look. The set includes a fridge, washing machine, stove, sink. Each door has a different picture.

The furniture can be used in various configurations: an island in the middle of the room, a row at a wall or as separate pieces in different parts of the room.

- dim. each one: 50 cm x 41 cm x 54 cm



Kitchen Island NS3219

- fridge 50 x 41 x 54 cm
- washing machine 50 x 41 x 54 cm
- sink 50 x 41 x 54 cm
- oven 50 x 41 x 54 cm



Oven NS3215

- dim.: 50 x 41 x 54 cm



Washing Machine NS3216

- dim.: 50 x 41 x 54 cm



Sink NS3217

- dim.: 50 x 41 x 54 cm



Fridge NS3218

- dim.: 50 x 41 x 54 cm



MALUCH KITCHEN



Workshop NS0265

A play corner for small do-it-yourselfers. The station is equipped with a wall with 3 small outlets and 12 large screw holes. On the tabletop there is a container in which work tools can be stored. The workshop has a lockable cabinet with two niches, on the other side there is space for 3 plastic containers. A vice was attached to the left side.

- set includes: table, 6 screws, attached vice, transparent plastic containers with lids 3 pcs in lime, blue and white;
- dim.: 56 x 38 x 78 cm;
- material: MDF board in mint color, chipboard in birch colour, additional elements made of wood;
- age: 3+



Fridge NS0264

The fridge is divided into the deep-freeze (upper part) and the cooler. Both parts open independently.

- size: 38 x 36 x 78 cm



Shelf unit NS0262

- size: 48 x 38 x 48 cm (58 cm with application)



Washing Machine NS0261

- size: 48 x 38 x 48 cm (68 cm with application)



Kitchen NS0260

- size: 68 x 38 x 48 cm (90 cm with application)

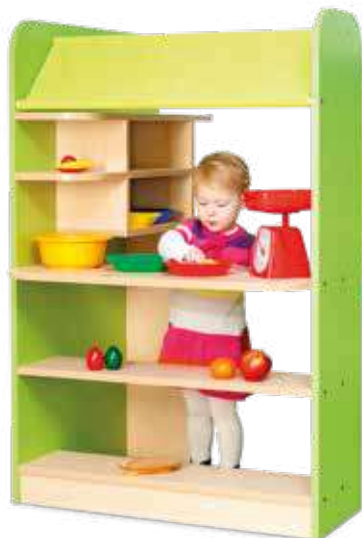

Market stall NS1837

- size: 123 x 82 x 81 cm



Noble Kitchen with accessories VG5022

A cooker with accessories. The cooker is equipped with an oven, a sink, a clock and two burners. Among the included accessories are a pan with a fried egg, a saucepan, a spatula, a spoon and two jars of spices. While playing with this set, children learn how to be organised and tidy.

- dim.: 47,5 x 70 x 30 cm; age: 3+



Chef's cooker CI4201

A wooden cooker with accessories thanks to which little cooks can prepare delicious meals. The size of the cooker allows two children to play at the same time. This set encourages the development of motor skills, it boosts creativity and teaches children how to plan their actions.

- dim.: 53 x 31 x 73,5 cm;
- age: 3+



Grey wooden cooker with accessories VG4049

A cooker with accessories. The cooker is equipped with an oven, a sink, a clock and two burners. Among the included accessories are a pan with a fried egg, a saucepan, a spatula, a spoon and two jars of spices. While playing with this set, children learn how to be organised and tidy.

- dim.: 47,5 x 70 x 30 cm;
- age: 3+



Turquoise wooden kitchen C10562

A big vintage kitchen thanks to which children will be able to feel like true chefs. The kitchen is equipped with many functional play elements: burners, an oven, a washing machine, a fridge,

a coffee machine, a microwave, a sink, a chalk board with a shopping list.

- 15 pcs.: a pan, a pot with a lid, a mug, salt and pepper shakers, 3 wooden kitchen utensils and 3 hooks, a wiper;
- dim.: 91 x 34 x 90 cm;
- material: wood, metal; age: 3+



Blue kitchen C14157

This Multi-functional modern kitchen with sink, oven and cupboards, provides a place where your little Master Chief can practice their craft.

- size: 55 x 30 x 75 cm; 9 pieces; age: 3+





MINT KITCHEN



Mint kitchen shelves
NS0289

- dim.: 88 x 13 x 103 cm; type: standalone; the frame is made of 18 mm thick hardwood plywoo; the corner has got 2 chipboard shelves in birch colour, each 12 mm thick



Mint sink unit
NS0287

- size: 104 x 37 x 56 cm; unit with a plastic sink



Mint washing machine
NS0288

- size: 104 x 37 x 56 cm; additional wooden iron



Kitchen combo unit mint
NS0290

- size: 104 x 37 x 56 cm; 3 gas rings and openable oven



**Market stall
NS0465**

- size: 80 x 80 x 1,0 cm

**Market stall roof
NS0579**

- red fabric;
- fits multipurpose stand NS0578



**Multipurpose stand
NS0578**

- serves as a play corner;
- with accessories can be used as a puppet theatre (NS0580)
- glass painting corner (NS0581) or market stall (NS0579)
- size: 84 x 51 x 113,5 cm



**Multi purpose shop center
NS0263**

A multi-purpose desk with counters for playing e.g. shop, post office or bank.

- made of MDF and laminated chipboard (birchwood)
- size: 100 x 50 x 1,0 cm





Playhouse ON1100

A special construction for playing house. Aesthetic curtains act as a puppet theatre. When set up, it is transformed into a room screen, and the side wall can be used as an easel for creating painting. The

height is suitable for children. Thanks to the cord hinges you can easily assemble or disassemble the construction.

- dim.: 95 x 60 x 1,5 cm;
- material: varnished plywood;
- age: 3+

STREETFOOD CARTS

Wooden coffee cart and food truck with a colourful canopy can also serve as a stall with vegetables and fruit. It will enliven educational activities related to the acquisition of new social competences through experience. Carts has wheels for free and easy transportation at home or daycare room. The top is large enough for all objects necessary in thematic play.

- size: 109 x 50 x 1,5 cm
- material: wood, MDF board
- age: 3+



Coffee cart
NS9075



Food truck
NS9076

KITCHEN'S ACCESSORIES



Coffee maker VG5025

Turn the switch with „kaka“ sound to have the machine „work“, push the button on top to have a cup of coffee.

- includes: a coffee maker, a cup and 1 piece of coffee;
- size: 21 x 19,5 x 11 cm;
- age: 3+



Kitchen Mixer VG5026

Turn the top button to rotate the beater, lift the handle on top to remove the bowl. Turn the switch with „kaka“ sound to have the machine „work“.

- size: 21 x 19,5 x 11 cm;
- age: 3+



Fruits and vegetables in wooden boxes. Classroom set VG4523

Vegetables and fruits made of wood painted with good quality paint. Their fun look encourages children to play.

They work well as toys or teaching aids in learning how to count, sort or name colours. Each box contains 7 fruits or vegetables, such as: pears, apples, garlic or aubergines.

- dim.: 19,7 x 14,4 x 5,4 cm; age: 3+

Mini microwave**TU0049**

Small microwave with lighting and sound. This interactive toy is a perfect addition to any children's kitchen. It is simple to use, all children need to do is open the door, put the chicken inside and use the switch to make the food spin and change colour while cooking.

- material: plastic; powering: 3 x AA batteries;
- dim. of the packaging: 27 x 13 x 18,5 cm;
- age: 3+

**Garden Grill****TU0060**

Grill set. Perfect for developing creativity and for playtime involving roleplay. This set also helps children to learn how to systemise their actions. The set includes kitchen tools such as a spatula, a meat fork, a plate, a ketchup, cooking tongs and bbq food.

**Jumbo. Set of play dishes****JN0510**

Set of 86 elements including: a tea set, a dinner set, a cooking and baking set, cutlery, cups and plates. A dish drainer

and a tray make sorting the elements easier. All elements are made of BPA-FREE plastic and because of it, they are safe for food storage, and they will provide years of fun.

**Pastel dinner set****JN0034**

Set of tableware in beautiful pastel colours. It is perfect for children who want to play and imitate adults in the kitchen, restaurant or cafe. The set contains 28 elements which can help with teaching toddlers how to use a knife and fork as well as setting the table. Additionally, it allows children to practice food preparation and

servicing meals according to the rules of etiquette. All of the set's elements are made of plastic, which makes them easy to clean and disinfect.

- 28 pcs.: 4 big plates, 4 small plates, 4 bowls, 4 mugs, 4 cups, 4 knives, 4 forks, 4 spoons;
- colour: pink, green, blue, purple;
- material: plastic;
- packaging: extruded mesh, 25 x 25 x 15 cm;
- age: 18 months +

**Tea set****JN0410**

Colourful tea set for every child who likes to play coffee or tea brewing with their friends or dolls. This product improves imagination and manual skills but most importantly, it

guarantees many hours of fun. The set consist of 18 elements made of plastic and it makes them durable and safe in use.

- 18 pcs.: 1 teapot, 2 lids, 1 sugar-bowl, 1 milk pot, 4 small plates, 4 teacups, 5 teaspoons;
- material: plastic; packaging: extruded mesh;
- age: 3+



Balance Scales VG5013

Made of high quality beech wood. The load trays can move on the scale arms to reach balance before loading the weights. Learn the theory of balance by playing this toy.

- includes: 1 stand, 2 load trays and 6 weights with 3 different sizes;
- size: 28 x 21,5 x 8,5 cm



Coffee Machine TU0011

- requires 2 pcs x AA batteries (not included);
- size: 16 x 13 x 21 cm



Tableware playset TU0012

- 1 set of tea pot, 4 sets of tea cup;
- size: 28 x 30 x 7 cm



Pretend play coffee maker with tumblers TU0046

It has an on/off knob and a button to activate sound and light effects.

- 6 elements: coffee maker, brew pot, 2 tumblers, 2 spoons;
- size: 13 x 9 x 18,5 cm;
- requires 2 AA batteries (not included);
- age: 3+



Cashier desk TU0015

- supper market set with the POP-UP, foods, fruit, vegetable etc.;
- size: 53 x 34 x 82 cm



Kitchen set TU0017

- requires 3 pcs x AA batteries (not included);
- size: 67 x 41 x 61 cm

PLAYING CORNERS



Small dentist. Wooden toy CI0556

A small dentist set allows children to engage into roleplay but at the same time it helps them to get used to doctor appointments as they will familiarise themselves with the course of the dental examination step by step. Children will additionally learn about the oral hygiene and the consequences of its absence.

Set includes:

- 1x jaw model (13 x 9 x 4,6 cm);
- 10 teeth (9 healthy, 1 bad, 1 with a hole, 1 with a filling);
- 1 x Mirror;
- 1 x dental drill;
- 1 x syringe;
- 1 x tongs for tooth extraction;
- 2 X-ray image;
- 1 x zip bag with a handle (dim.: 23 x 14 x 7 cm); age: 3+



Wooden doctor's kit CI4419

This set of 19 elements is mainly made of wood and it contains a stethoscope, a syringe, a thermometer, a patient card and tweezers.

- dim.: 22,5 x 17 x 8 cm;
- age: 3+



Garden cart
TU0019

- size: 32 x 32 x 58 cm



Cleaning set
TU0020

- size: 27 x 30 x 52 cm



Doctor cart
TU0024

- size: 40 x 35 x 42 cm



Tool cart
TU0021

A workshop on wheels which is equipped with all necessary tool for crafting. By following the steps of adults, children will get a chance to see what it is like to tighten screws or use a hammer. Any urgent matters won't have to wait thanks to the workshop's mobile character.

Product specification:

- dim.: 30 x 51 x 30,5 cm; workshop on wheels with 36 elements;
- material: plastic; age: 3+



Beach shovel
TU0023

- size: 55 x 12 x 5 cm;
- 1 pc



Dresser set
TU0014

A vanity for a real princess. The toy is enriched with light and sound effects.

- the set includes 16 elements: a table with a mirror, a chair, a hairdryer, a hair comb, 2 hair ties, jewellery (3 rings, 2 bracelets), 3 perfume bottles, and toy make-up: 2 lipsticks;
- dim.: 65 x 51 x 11,5 cm;
- requirements: a mirror – 3 AA batteries;
- a hairdryer – 1 AA battery (not included);
- the product has to be assembled; age: 3+



Dressing table NS1724

A dressing table with a drawer, cabinet and a mirror.

- size: 69 x 32 x 80 cm;
- sold without chair



Pretend play vacuum cleaner

TU0043

A toy which allows a child to pretend play doing cleaning activities. It has a suction mode in which styrofoam pellets (included) are collected into

a special container accompanied by realistic light and sound effects.

- 5 elements: vacuum cleaner, pipe, hose, nozzle, styrofoam pellets in a bag;
- material: plastic;
- size: 20 x 15 x 12 cm;
- age: 3+

Pretend play sewing machine

TU0044

Make a dress of your own design! The toy has a steel needle in a transparent case for safety, manual mode, light switch and a drawer for accessories. Attached are a piece of fabric and push-on spools with thread.

- size: 22 x 10 x 20,5 cm;
- 4 x 1,5 V battery required (not included);
- age: 3+



Pretend play washing machine with hooks

TU0045

The toy represents a real appliance. It has a detergent drawer and a knob

to control the washing temperature. The machine's door is openable. The on/off button switches on the drum motor, red LED indicator and sounds of a working washing machine.



Wooden toolbox play set QH3333

A wooden box with tools for real DIY activities. It has drawers and holders which help the child to learn to keep things tidy. The holders keep the tools safely inside while carrying them around and/or flipping the box over.

- open box size: 40 x 30 cm;
- contents: 2 hammers, 2 spanners, handsaw, pliers, ruler, vice, 2 screwdrivers, 7 small pegboards, many screws and nuts;
- age: 3+



46 elements

Tool kit TU0040

This set helps develop dexterity, imagination, creativity and independent thinking in children. It contains all basic tools necessary in a workshop: a hammer, screwdriver, drill, hand saw, plastic screws, boards with holes, vice (46 elements in total)

- size: 50 x 26 x 75 cm



Tool Box CI3511

Good size of hammer, wrench, pliers, etc. for the budding carpenter.

- size: 24 x 13 x 14 cm; 16 pcs;
- age: 3+



Children's workbench CI5108

The workbench consists of a work surface and a tool panel with a clip for holding paper when drawing. The handy storage shelf can be mounted at different heights. With the elements in the set a car, an animal or a clock can be constructed.

- 86 elements in the set;
- assembly required;
- tools: handsaw, vice, hammer, chisel, screwdriver, measuring tape
- size: 50 x 35 x 95 cm;
- age 3+



Workshop NS0265

A play corner for small do-it-yourselfers. The station is equipped with a wall with 3 small outlets and 12 large screw holes. On the tabletop there is a container in which work tools can be stored. The workshop has a lockable cabinet with two niches, on the other side there is space for 3 plastic containers. A vice was attached to the left side.

- set includes: table, 6 screws, attached vice, transparent plastic containers with lids 3 pcs in lime, blue and white
- dim.: 56 x 38 x 78 cm;
- material: MDF board in mint color, chipboard in birch colour, additional elements made of wood; age: 3+



Yellow workshop C10176

A workshop which allows little DIY-enthusiasts to measure, nail, repair and put together things with tools such as a hammer, a chisel, a wrench, a saw,

pliers, a vice, a calliper, a circular saw, a tape measure and plenty of wooden planks, screws as well as gears. All steps can be written on the chalkboard.

- dim.: 43 x 39 x 56 cm;
- material: wood; age: 3+





Soccer table
MK0001

- size: 125 x 101 x 79 cm;
- made of laminated MDF;
- color: black



Foam mat Street
MW0011

- 9 pcs;
- size: 30 x 30 cm



REFLECTIVE VEST

The vest can be put on by pulling it over the head. Thanks to the elastic bands on the sides, putting it on is easy and the vest fits better. Side slits provide air circulation when it's hot outside, and when it's cold, they stretch to make room for a thick, warm jacket. On the front, there is a reflection with Nowa Szkoła logo.

- fabric: polyester.



Reflective vest for toddlers
NS2090

- 1 pc.; size.: 37 x 43 cm



Reflective vest
NS2066

- 1 pc.; size.: 50 x 60 cm



Table Tent - Underwater World NS2122

The drill cotton tent creates a safe and intimate place for play for any toddler. Comes with numerous underwater motifs, drawstrings, 2 round windows and 2 entrances with velcroed curtains.

- size: 75 x 120 x 60 cm;
- washable 40°C; age: 1+



Letters and numbers puzzle mat ST0483

Multi-coloured interlocking tiles with letters (A-Z) and numbers (0-9). When connected the tiles make a mat for manual and motor activities or for

rest. The colour scheme, material and its texture stimulate the senses of touch and sight.

- 36 pcs, 32 x 10 x 32 cm each
- material: EVA foam
- package size: 62 x 13 x 32 cm;
- age: 10 months+



Kindergartener's car NS0973

An elegant car equipped with moving elements which will make children feel like small drivers! The vehicle develops creativity and motor skills of the youngest. It is made of plywood and foam covered with durable fabric. Among the moving parts we can find

colourful, soft wheels (a spare wheel is included in the set) fastened with Velcro, headlights (fastened with Velcro), a steering wheel, a gearbox, an openable hood, a trunk, and a removable seat.

- dim.: 150 x 74 x 74 cm
- material: 18 mm plywood, polyurethane foam, red phthalate-free PVC fabric; age: 3+



Off-road car NS1838

- size: 178 x 107 x 72 cm



**Vet. Wooden house
with accessories
VG4558**

Set of 19 elements stored in a suitcase which makes transporting and storing the folding house much easier. Playtime with the house teaches children

empathy towards animals, it helps them to develop their imagination and social skills. The set includes: a dog, a vet, a nurse, a cat, food for animals, toys for animals and medical instruments. It is mainly made of wood.

- dim.: 22,5 x 12,2 x 16,8 cm; age: 3+



**Two-story garage with a lift
CI3658**

Colourful, two-story garage with a transparent lift, two cars and a helicopter. It boosts children's creativity through its various elements, such as: a lift, vehicles, a car wash or a gas pump. This set is perfect for developing the narrative skills.

- dim.: 62 x 30 x 37 cm;
- age: 3+



**Beauty salon for pets
TU0057**

Set of 22 elements, including: a hairdryer, a shampoo, a hairbrush and scissors. All elements are made of durable plastic. Perfect for games involving roleplay, boosting creativity and learning the meaning of responsibility.

- dim.: 37 x 20,5 x 54,5 cm;
- age: 3+





2023

international



mail
export@nowazskola.com



address
POW 25
90248 Lodz - Poland



telephone
+48 42 639 97 37



internet
www.nowazskola.com

nowa szkoła